

## Secondary Air Injection (AIR) system

- ◆ Check Diagnostic Trouble Code (DTC) memory.

⇒ *Repair Manual, 2.8 Liter V6 5V Fuel Injection & Ignition, Repair Group 01*

- ◆ Initiate output Diagnostic Test Mode (DTM).

⇒ *Repair Manual, 2.8 Liter V6 5V Fuel Injection & Ignition, Repair Group 01*

- ◆ Initiate "Basic Setting" (scan tool function 04).

⇒ *Repair Manual, 2.8 Liter V6 5V Fuel Injection & Ignition, Repair Group 01*

- ◆ Check Secondary Air Injection (AIR) valve.

⇒ *Repair Manual, 2.8 Liter V6 5V Fuel Injection*

*& Ignition, Repair Group 01*

**Notes:**

- ◆ *The secondary air injection system injects air behind the exhaust valves during a cold start. Cold start means engine coolant temperature between 8-65° C (46-149° F). The amount of air injected is temperature dependent.*
  
- ◆ *The need for secondary air is triggered by the Motronic Engine Control Module (ECM) -J220- via the Secondary Air Injection (AIR) Injection pump relay -J299- to the Secondary Air Injection (AIR) solenoid valve -N112- and the two combination valves.*
  
- ◆ *When "Basic Setting" (scan tool function 04) is initiated, a diagnosis for the secondary air injection system can be carried out. The diagnostics consists of a flow test and a leak test.*

### **Flow test**

During the flow test, the oxygen sensor control is switched off (engine runs rich at that time). At the same time the secondary air injection pump is switched on, injecting fresh air into the exhaust manifold which increases the oxygen content in the exhaust gas. The oxygen sensor now measures a lean mixture. To pass the diagnostic test, the oxygen sensor must measure a lean mixture for a certain time. Passing the test means that the secondary air injection system delivers enough air and the secondary air injection system is OK.

### **Leak test**

- Flow test must check out OK
- Engine at operating temperature

The secondary air injection pump is switched on during idle. Since the combination valves are not triggered by the secondary air injection solenoid valve, they remain closed. When the secondary air injection pump is switched on, the oxygen sensor system is monitored by the ECM. If the system does not leak, fresh air cannot enter the exhaust manifold. If the system is leaking, the oxygen sensor signal will respond to the leaner mixture (caused by the secondary air getting into the exhaust manifold) and cause a noticeable

enrichment. This enrichment is recognized by the ECM.

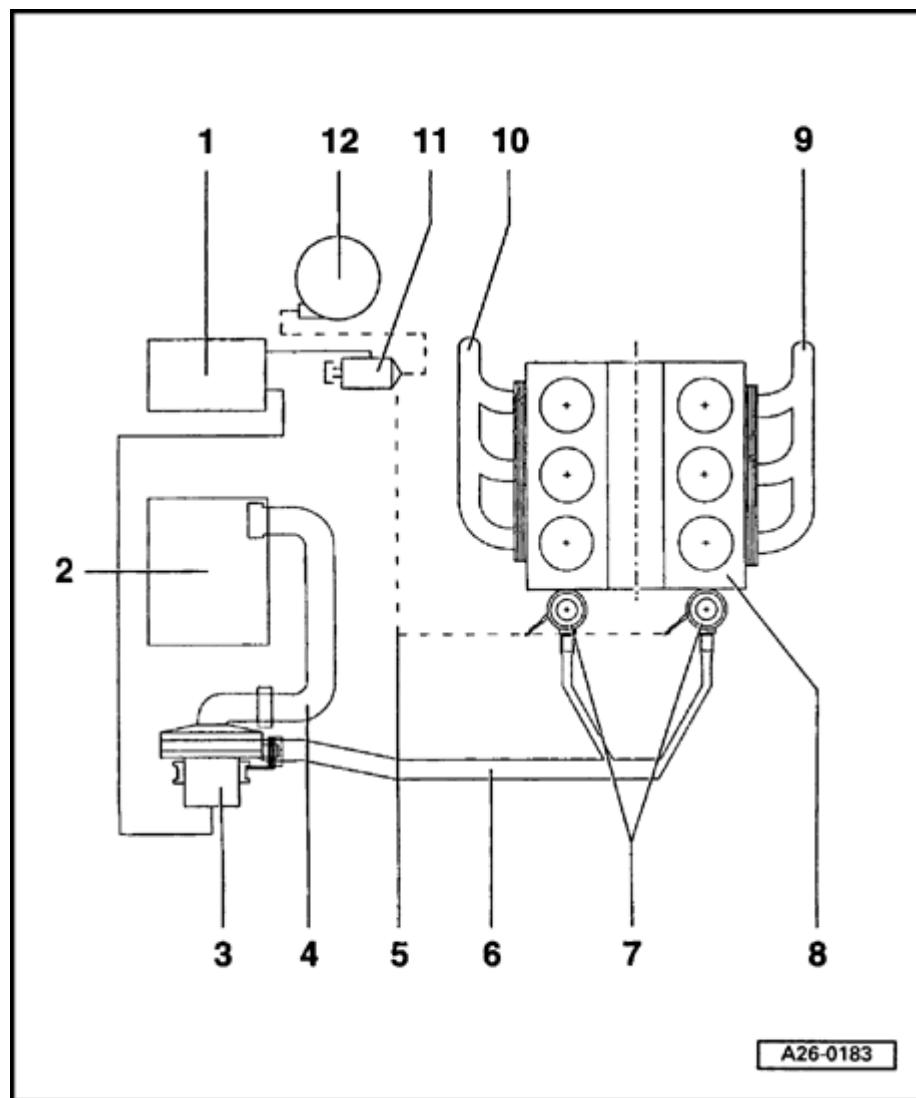

## Secondary Air Injection (AIR) system, overview

- 1 - Motronic Engine Control Module (ECM) - J220-**
- 2 - Air cleaner**
  - ◆ Connection for intake air of Secondary Air Injection (AIR) pump
- 3 - Secondary Air Injection (AIR) pump motor -V101-**
- 4 - Connection**
  - ◆ Between air cleaner and secondary air injection pump
  - ◆ Removing ⇒ [page 26-16](#)
- 5 - Vacuum line**
  - ◆ Control line between Secondary Air Injection (AIR) solenoid valve -N112- and combination valves
- 6 - Connection tube**
  - ◆ From secondary air injection pump to combination valves

26-15

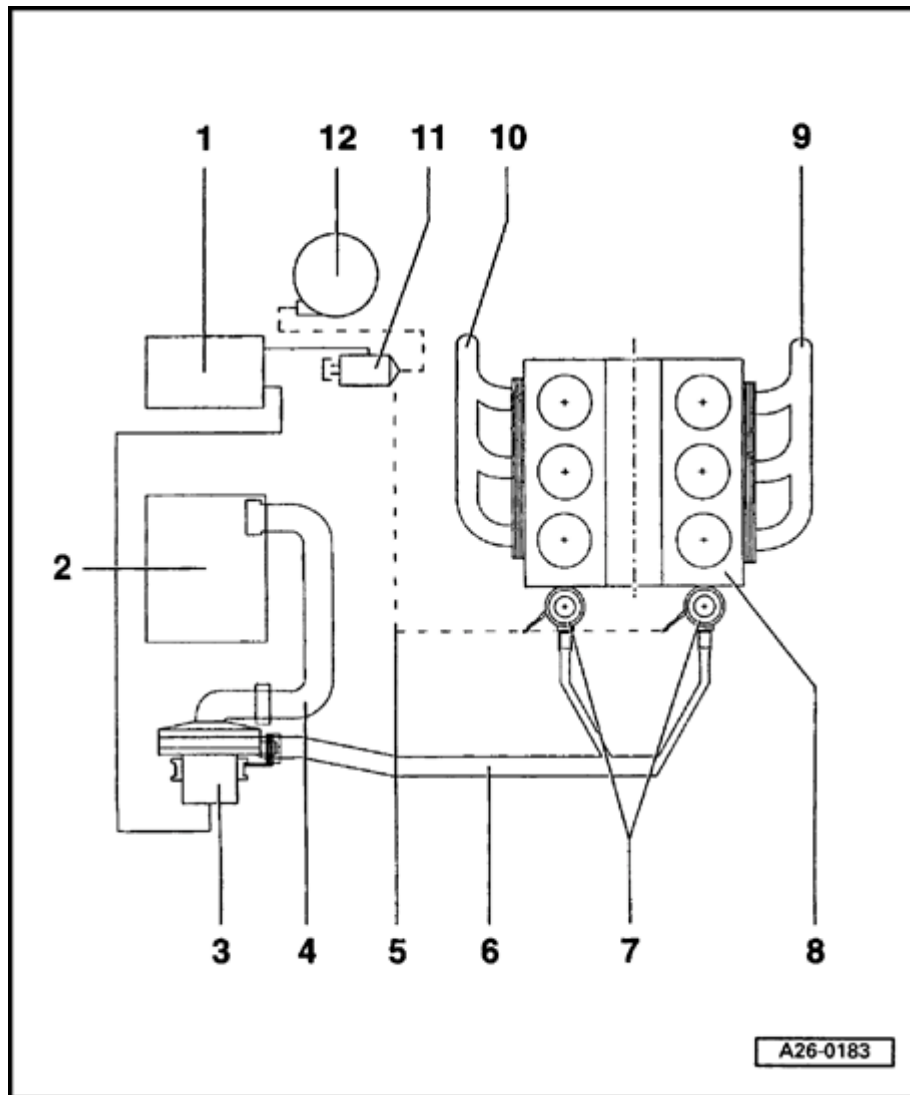
**7 - Combination valves**

- ◆ Located at rear of left and right cylinder heads
- ◆ Removing and installing ⇒ [page 26-16](#)

**8 - Engine****9 - Right exhaust manifold****10 - Left exhaust manifold****11 - Secondary Air Injection (AIR) solenoid valve -N112-****12 - Vacuum reservoir**

- ◆ Located in left-front wheelhousing

## Secondary Air Injection (AIR) system components, removing and installing

Component locations ⇒ [page 26-14](#) .

Fuel injection and ignition components.

⇒ *Repair Manual, 2.8 Liter V6 5V Fuel Injection & Ignition, Repair Group 24*

### **Note:**

*Always replace gaskets and seals.*

### **A - Combination valve, left**

- Remove engine coolant expansion tank from bracket.

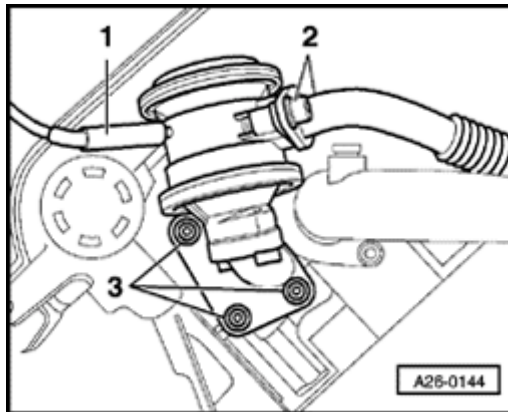

**A**

- Disconnect vacuum line -1-.
- Disconnect connection tube -2- from combination valve.  
Tightening torque: 10 Nm (7 ft lb).
- Remove bolts -3- for combination valve from cylinder head and remove valve.  
Tightening torque: 10 Nm (7 ft lb).

26-17

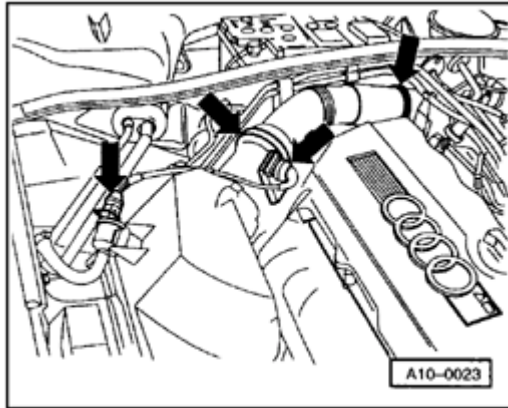
**B - Combination valve, right****A**

- Remove intake air duct between Mass Air Flow (MAF) sensor and intake air elbow (three -arrows- on right).
- Remove intake air elbow from throttle body connector.
- Disconnect harness connector for Evaporative Emission (EVAP) canister purge regulator valve (left arrow) and pull valve out of bracket.
- Disconnect harness connector at Mass Air Flow (MAF) sensor.

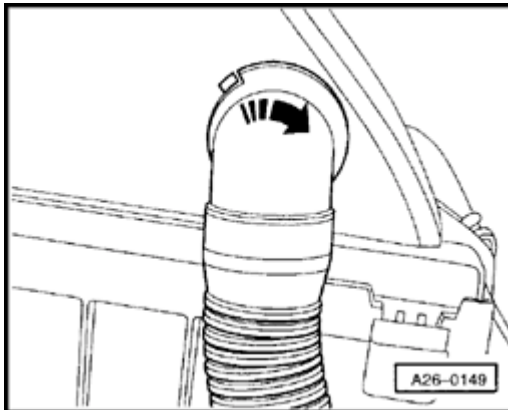
**A**

- Turn connector tube for Secondary Air Injection (AIR) pump 1/4-turn (45°) to right and pull forward off air cleaner.
  - Remove air cleaner housing.
- Tightening torque: 20 Nm (15 ft lb).



26-18

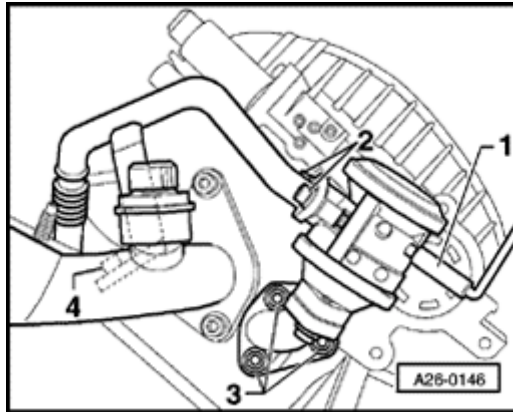

A

- Remove vacuum line -1-.
- Disconnect connection tube -2- from combination valve.  
Tightening torque: 10 Nm (7 ft lb).
- Remove bolts -3- for combination valve from cylinder head and if necessary, remove bracket -4- from cylinder head.
  - ◆ Bolt -3- tightening torque: 10 Nm (7 ft lb).
  - ◆ Bracket -4- tightening torque: 20 Nm (15 ft lb).
- Remove combination valve.

### C - Secondary Air Injection (AIR) pump motor

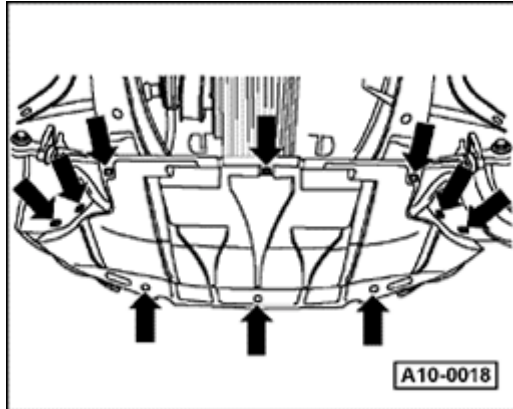

A

- Remove noise insulation panel (arrows).
- Remove front bumper.  
⇒ [Repair Manual, Body Exterior, Repair Group 63](#)
- Move lock carrier into service position.  
⇒ [Repair Manual, Body Exterior, Repair Group 50](#)

26-19

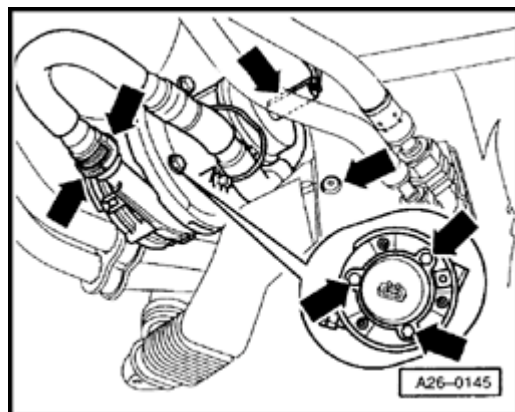

- A
- Remove air duct to generator at front of air shroud.
  - Disconnect connection at connector tube to Secondary Air Injection (AIR) pump combination valves (left arrows), pull down to remove and cut tie wraps.
  - Remove three bolts on Secondary Air Injection (AIR) pump (lower right arrows) but do not remove nuts.
  - Remove pump toward rear from bracket.
  - Remove connection line on Secondary Air Injection (AIR) pump to air cleaner.

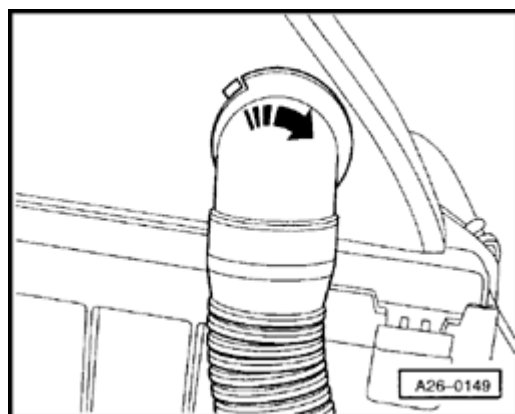

- A
- Turn connector tube for Secondary Air Injection (AIR) pump 45° to right and disconnect.
  - Remove air Secondary Air Injection (AIR) pump.

### Installing

Installation is the reverse of removal.