

Workshop Manual FABIA 2000 ➤

Gearbox 002 Edition 08.99								
Gearbox code	EMH	FCM	FNK	FJQ	GCG			



List of Supplements to Workshop Manual

FABIA 2000 >

Gearbox 002

Edition 08.99

Supplement	Edition	Subject	Article Number
	08.99	Basic Edition	S00.5315.00.20
1	04.00	Supplement to the basic edition	S00.5315.01.20
2	08.00	Modifications to the differential gear	S00.5315.02.20
3	05.02	Changes to the speed sender, draining oil	S00.5315.03.20

Table of Contents

00 – Technical Data

Identification of the gearbox	00-1	page 1
- Identification characters, aggregate assignment, ratios, capacities	00-1	page 2
Overview of Power Transmission	00-2	page 1
- Designation of components and transmission ratio	00-2	page 1
General Repair Information	00-3	page 1

30 – Clutch

Clutch control	30-1	page 1
- Summary of components - Foot controls	30-1	page 1
- Removing and installing the over-centre helper spring	30-1	page 2
- Removing and installing the clutch pedal	30-1	page 3
- Summary of components - Hydraulics	30-1	page 4
- Removing and installing the master cylinder	30-1	page 5
- Bleeding the clutch system	30-1	page 7
Removing and installing the clutch control	30-2	page 1
Repairing the clutch	30-3	page 1

34 – Control, housing

Shift mechanism	34-1	page 1
- Fitting location of shift mechanism	34-1	page 1
I - Gearshift knob and cover - Summary of components	34-2	page 1
- Separating collar from gearshift lever	34-2	page 2
Assembly Overview – Shift Lever and Shift Housing	34-3	page 1
Assembly Overview – Control Cables	34-4	page 1
Removing and Installing Shift Mechanism	34-5	page 1
- Removing	34-5	page 1
- Installing	34-5	page 2
Setting Shift Mechanism	34-6	page 1
- Function	34-6	page 3
Removing and installing the gearbox	34-7	page 1
- Removing	34-7	page 1
- Installing	34-7	page 6
Inspecting gear oil	34-8	page 1
- Draining out gear oil	34-8	page 1
Disassembling and assembling the gearbox	34-9	page 1
- I - Disassembling and assembling gearbox housing cover and 5th gear	34-9	page 2
- II - Disassembling and assembling the gearbox housing, drive shaft, output shaft (input shaft), differential and shift mechanism	34-9	page 3
- Mounting sequence	34-9	page 4
Repairing the gearbox housing	34-10	page 1
Repairing the clutch housing	34-11	page 1
Disassembling and assembling the gearshift mechanism on the gearbox side	34-12	page 1
Disassembling and assembling the gearshift forks	34-13	page 1

35 – Wheels, shafts

Disassembling and assembling the drive shaft	35-1	page	1
Disassembling and assembling the output shaft (input shaft)	35-2	page	1
Disassembling and assembling the reverse shaft support	35-3	page	1

39 – Final drive, differential

Replacing the flange shaft gasket rings (gearbox fitted)	39-1	page	1
- Replacing the left flange shaft gasket ring	39-1	page	1
- Replacing the right flange shaft gasket ring	39-1	page	3
Disassembling and assembling the differential	39-2	page	1
Adjusting the differential gear	39-3	page	1

00 – Technical Data

00-1 Identification of the gearbox

Assignment ⇒ **00-1** page 2

Location on the gearbox

Identification characters of the gearbox -arrow 1-

Manufacturing date of the gearbox -arrow 2-

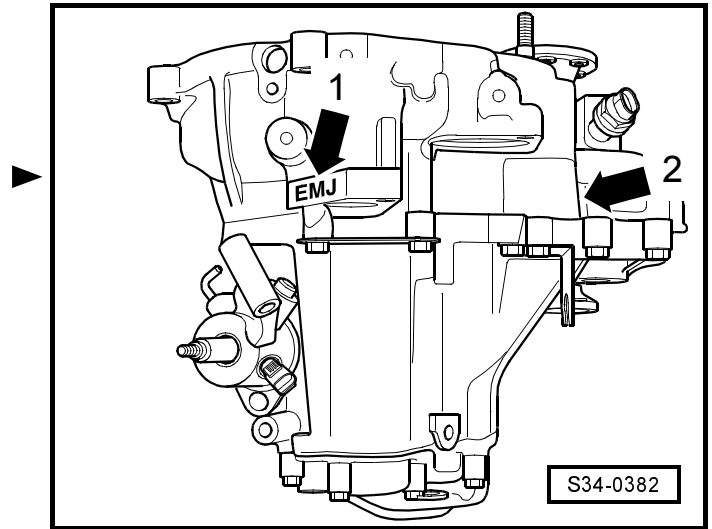

Manufacturing data of the gearbox

- a - Production number of the gearbox
- b - Coding for manufacturing year

Code	Year
X	1999
Y	2000
1	2001
2	2002
3	2003
4	2004
5	2005

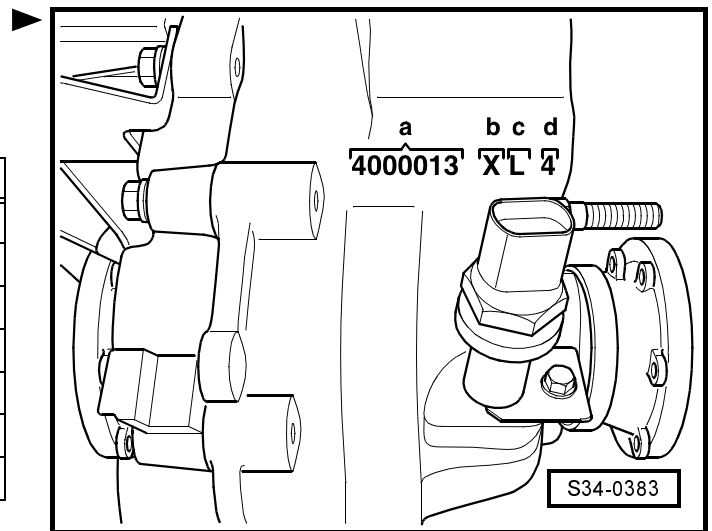

- c - Manufacturing month

Code	Month	Code	Month
L	January	C	July
U	February	S	August
B	March	Z	September
D	April	R	October
K	May	T	November
N	June	P	December

- d - Gearbox ratio

Code	Final drive ratio
4	4,120
8	4,867

Identification characters, aggregate assignment, ratios, capacities

Manual gearbox		5 gear 002				
Identification characters		EMH	FCM	FNK	GCG	FJQ
Manufactured	from	08.99	06.00	09.00	08.02	10.00
	until	05.00	08.00			
Assignment:	Engine	1.4 l/50 kW and 1.4 l/44 kW				1.0 l/37 kW
Ratio:	Final drive	70:17 = 4,118				73:15 = 4,867
$Z_2 : Z_1$	1. Gear	45:13 = 3,462				46:12 = 3,833
	2. Gear	45:23 = 1,957				45:23 = 1,957
	3. Gear	38:29 = 1,310				38:29 = 1,310
	4. Gear	39:40 = 0,975				39:40 = 0,975
	5. Gear	34:45 = 0,756				34:45 = 0,756
	Reverse gear	29:13 x 38:29 = 2.923				29:11 x 41:29 = 3.727
	Speedometer	27:16 = 1,688				27:16 = 1,688
Capacity	2.0 l					
Gear oil specification	Gearbox oil G50 SAE 75W90 (synthetic oil)					
Gear oil change interval	Filled for life					
Clutch control	hydraulic					
Clutch plate \varnothing	190 mm					
Drive shaft - flange \varnothing	89 mm					

00-2 Overview of Power Transmission

Designation of components and transmission ratio

i Note!

The arrows point in the direction of travel.

- 1 - Engine
- 2 - Clutch
- 3 - Gearbox
- 4 - Drive shaft
- 5 - Output shaft/input shaft
- 6 - Differential
- I - 1. Gear
- II - 2. Gear
- III - 3. Gear
- IV - 4. Gear
- V - 5. Gear
- R - Reverse gear
- A - Final drive
- T - Speedometer drive

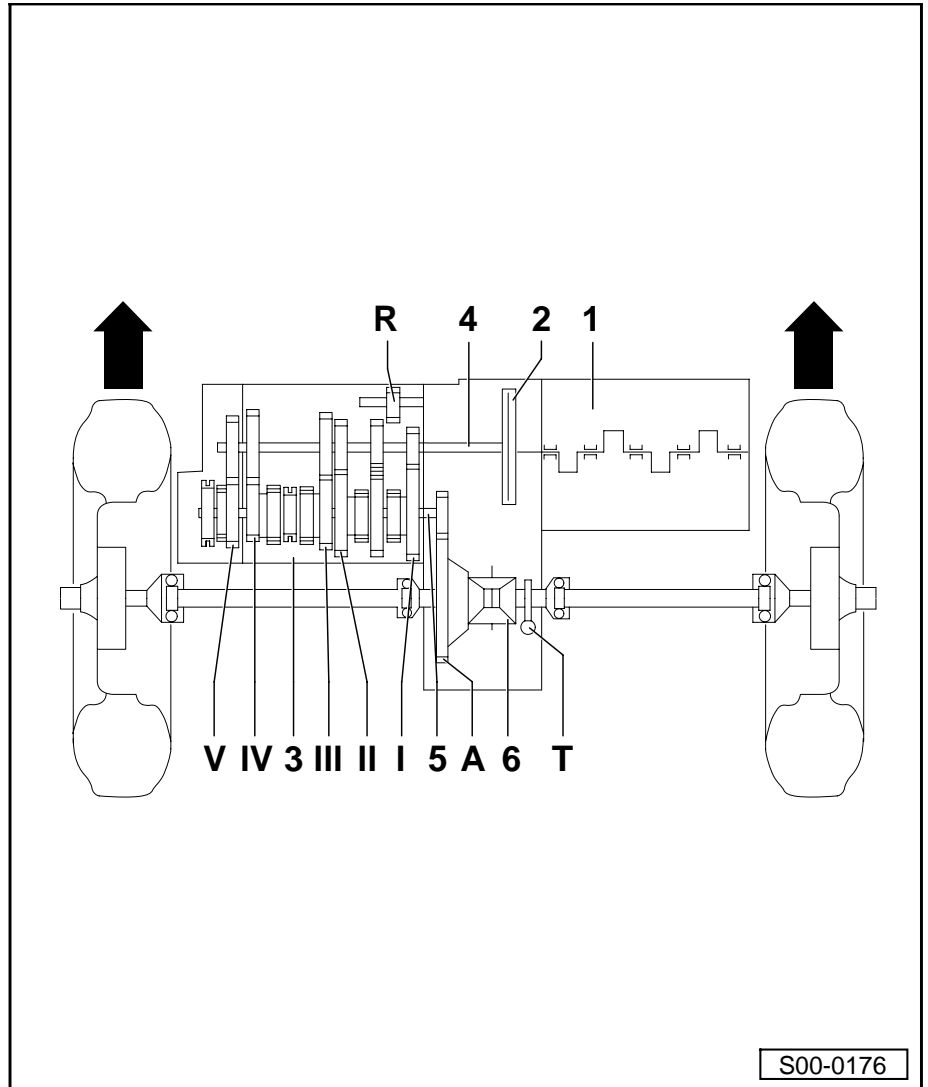

00-3 General Repair Information

Scrupulous care and cleanliness, as well as the proper tools, are essential requirements for carrying out proper and successful gearbox repairs. The generally valid basic rules of safety also, of course, apply to repair work.

A number of generally valid notes for individual repair operations – which are otherwise listed several times at numerous points in the workshop manual – are summarized here. They apply to this workshop manual.

Gearbox

- ◆ When installing, ensure the dowel sleeves are correctly located between engine and gearbox.
- ◆ If the gearbox is replaced, pour in gear oil up to lower edge of filler hole.
- ◆ Capacity and specification ⇒ Chap. 00-1.

Gaskets, seals

- ◆ Thoroughly clean contact surfaces and apply THREE BOND 1104 sealant.
- ◆ Apply sealant evenly – not too thick.
- ◆ Replace O-rings.
- ◆ Replace radial shaft seals.

Before installing:

Lightly oil the outer diameter and pack the space between the sealing lips -arrow- with grease. ►

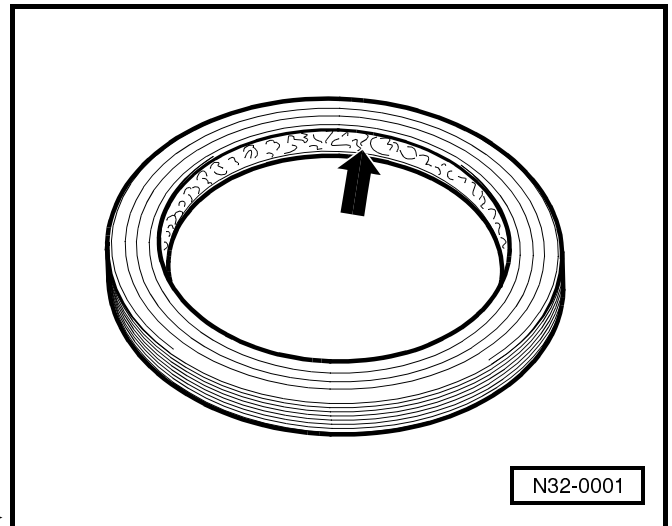

After installing:

Inspect gear oil level; top up, if necessary, to lower edge of filler hole. Specification ⇒ Chap. 00-1.

Locking elements

- ◆ Replace circlips.
- ◆ Do not over-tension circlips.
- ◆ Circlips must be positioned in the base of the groove.
- ◆ Replace roll pins. installation position: slot longitudinally to power flow -arrow-. ►

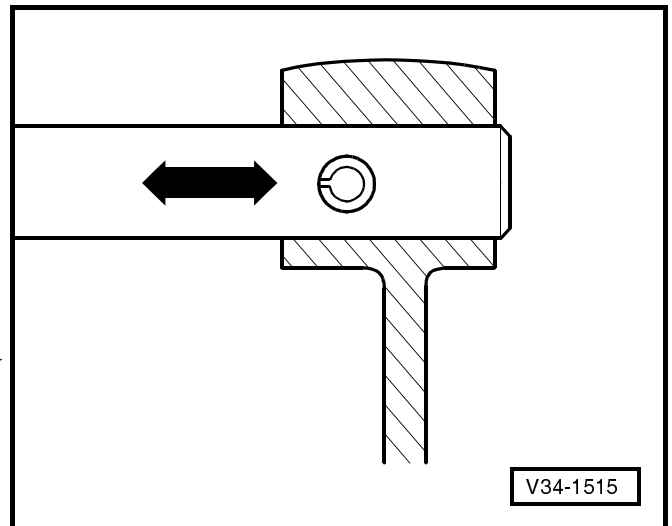

Nuts, bolts

- ◆ Slacken and tighten nuts and bolts for attaching covers and housings diagonally across.
- ◆ Do not twist particularly sensitive parts – such as clutch pressure plates – and slacken and tighten diagonally across in stages.
- ◆ Tightening torques apply to non-oiled nuts and bolts.
- ◆ Always replace self-locking nuts and bolts.
- ◆ It is important to ensure at all bolted connections that the contact surfaces as well as the nuts and bolts are waxed only after being installed, should this be necessary.

Bearings

- ◆ Install new taper roller bearings as supplied, and do not oil additionally.
- ◆ Insert needle bearings in gearbox with gear oil.
- ◆ Always replace all the taper roller bearings fitted to a shaft. Use the same make of bearings, if possible!
- ◆ Heat inner races to about 100 °C for installing.
- ◆ Do not mix up the outer and inner races of bearings of the same size. Bearings are matched.
- ◆ Position needle bearing with the inscribed side (thicker metal wall) facing the insertion drift.

Shims

- ◆ Gauge shims at several points with a micrometer. Different tolerances make it possible to exactly determine the required thickness of shim.
- ◆ Inspect for burrs and damage.
- ◆ Install only shims which are in perfect condition.

Synchronizer rings

- ◆ Do not mix up. Assign synchronizer rings to the same gear when re-using.
- ◆ Inspect for wear, replace if necessary.
- ◆ Insert with gear oil.

Gears

- ◆ Clean and heat on a heating plate to about 100 °C before pressing on.
- ◆ The temperature can be verified with a temperature measuring device (e.g. -V.A.G 1558-).

30 – Clutch

30-1 Clutch control

Summary of components - Foot controls

Special tools, test and measuring equipment and auxiliary items required

- ◆ Polycarbamide grease -G 052 142 A2-



Note

- ◆ Summary of components - Hydraulics ⇒ **30-1** page 4.
- ◆ Disconnect earth strap of the battery.
- ◆ Before disconnecting the battery determine the code of radio sets fitted with anti-theft coding.
- ◆ If the battery earth strap is disconnected and connected, carry out additional operations ⇒ Electrical System; Rep. Gr. 27.
- ◆ Grease all bearing and contact surfaces with polycarbamide grease -G 052 142 A2-.
- ◆ Prior to working on the foot controls remove the storage area on the driver's side ⇒ Body Work; Rep. Gr. 70.

1 - Support/Front wall

- for master cylinder and bracket

2 - Gasket

- always replace when installing

3 - Bracket

4 - Screw

5 - Gas/brake foot controls

6 - 25 Nm

- always replace when installing

7 - Clutch pedal switch

- Always push the clutch pedal down when removing or installing the switch.
- before removing the clutch pedal ⇒ item 11 turn the switch 90° to the right and lead out through the removal opening

8 - Over-centre helper spring

- removing and installing ⇒ **30-1** page 2

9 - Spacer bush

10 - Bushing

11 - Clutch pedal

- removing and installing ⇒ **30-1** page 3

12 - Support

13 - 25 Nm

- always replace

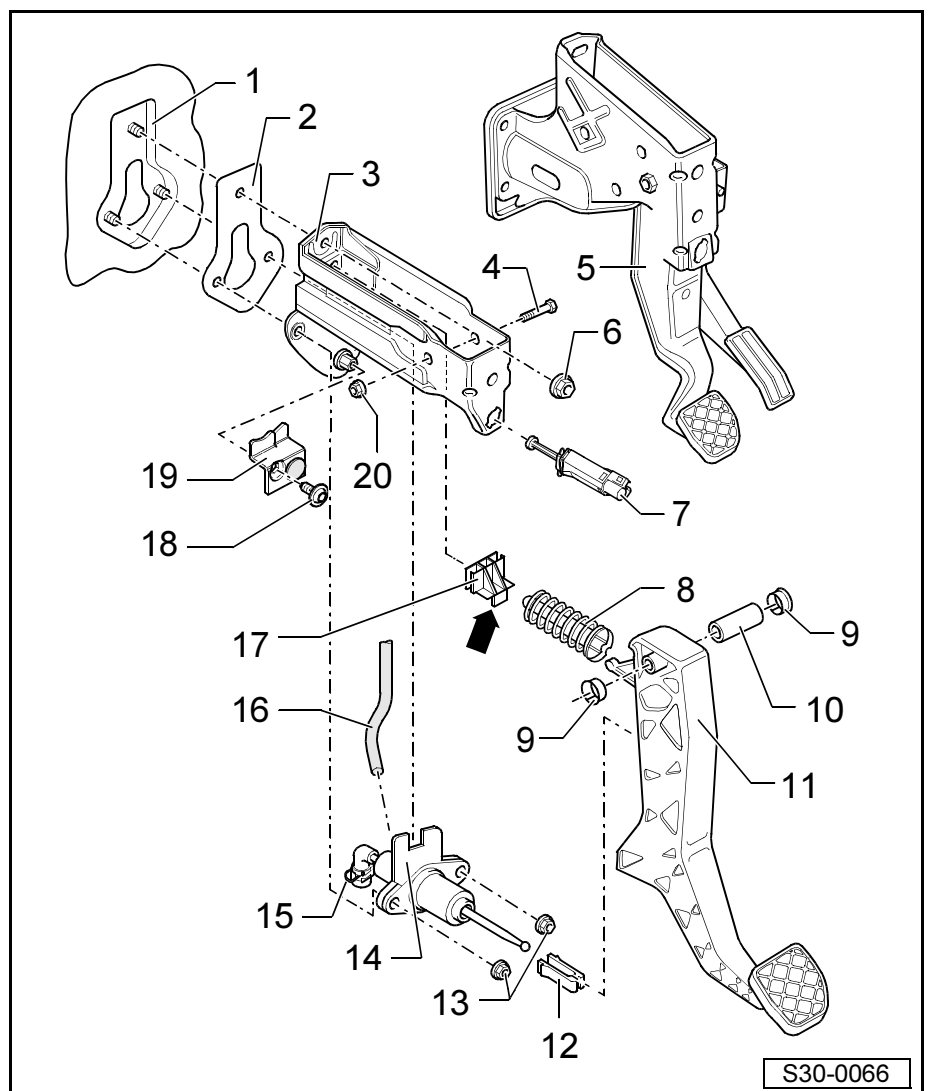

S30-0066

14 - Master cylinder

- removing and installing ⇒ **30-1** page 5

15 - Circlip**16 - Tubing****17 - Bearing/over-helper centre spring**

- insert in bracket
- always replace
- Fitting position: the peg -arrow- clips into the master cylinder recess

18 - Screw

- Pedal stop on bracket

19 - Pedal stop

- screw onto bracket with screw ⇒ item 18 in **30-1** page 2

20 - 25 Nm

- always replace

Removing and installing the over-centre helper spring

Special tools, test and measuring equipment and auxiliary items required

- ◆ Pliers -T10005-

Removing:

- Remove the storage area on the driver's side ⇒ Body Work; Rep. Gr. 70.
- Remove clutch pedal switch.

Unlock the actuating rod/master cylinder from the clutch pedal as follows:

- Insert pliers -T10005- in the clutch pedal recesses. ►
- Press support and separate the clutch pedal from the master cylinder.
- Push the over-centre helper spring against the partition panel -in the direction of the arrow- and remove from the bracket from the bottom. ►

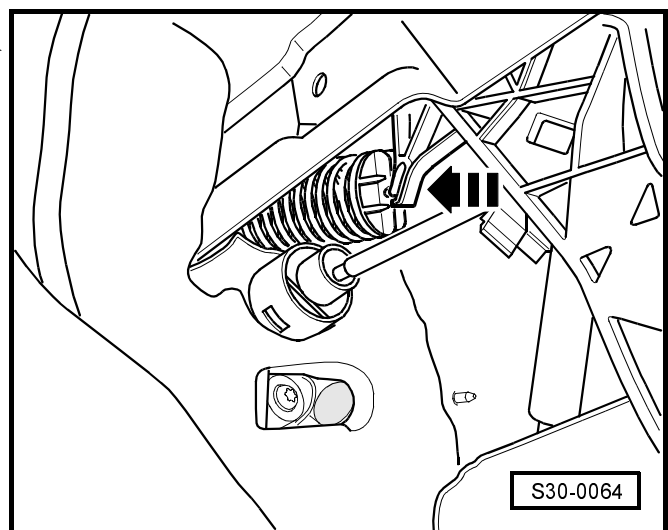
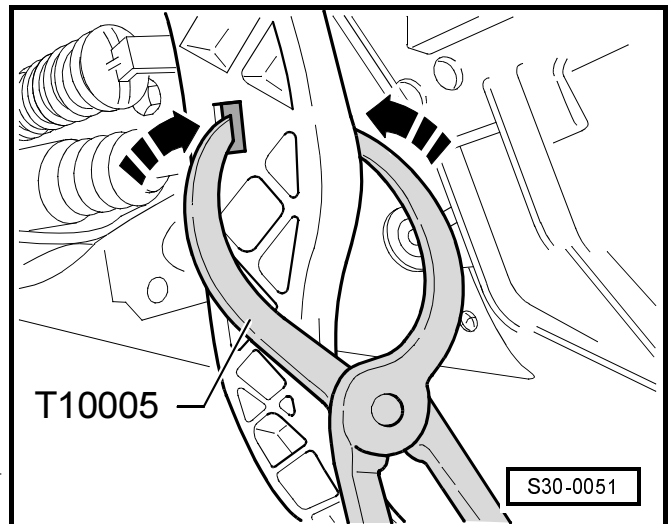

Installing:

- Insert bearing for over-centre helper spring -arrow 1- in the bracket holder.

The peg of the bearing is located in the recess of the master cylinder -arrow 2-.

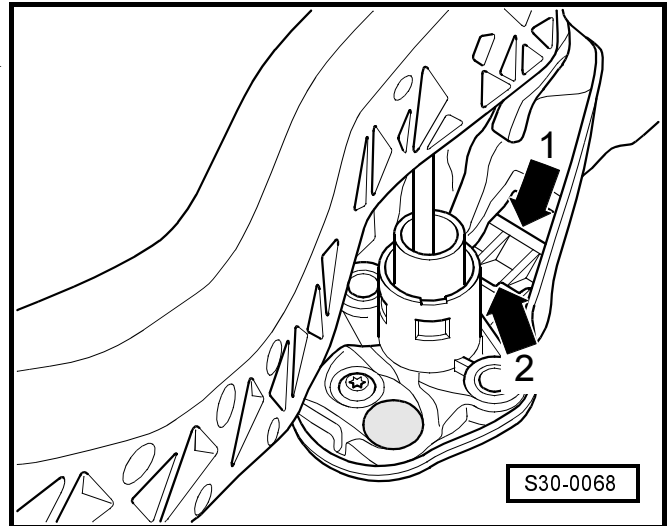

- Insert over-centre helper spring in the bearing.
- Press over-centre helper spring against the bearing and position on the support of the clutch pedal -arrow-.
- Position the clutch pedal with the master cylinder ⇒ **30-1** page 3
- Installing the clutch pedal switch.
- Install the storage area on the driver's side ⇒ Body Work; Rep. Gr. 70.

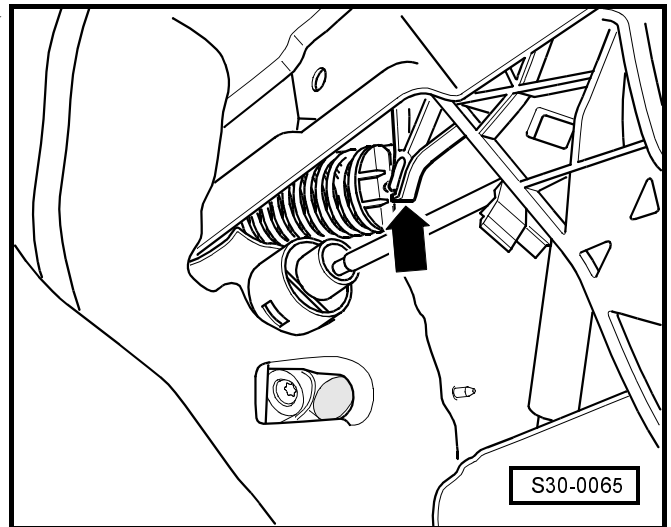

Removing and installing the clutch pedal

Removing:

- Remove the over-centre helper spring ⇒ **30-1** page 2
- Unscrew the nut -A- and pull screw out of the pedal bracket.
- Remove clutch pedal.

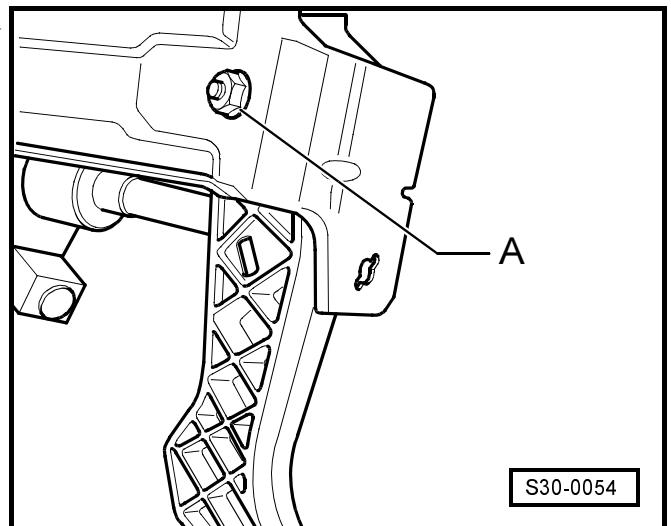

Installing:

The installation occurs in reverse order, while paying attention to the following:

- The support -A- must be located on the actuating rod -B- of the master cylinder. ▶
- To click in the support push the clutch pedal towards the front wall -direction of the arrow- and make sure it catches correctly.

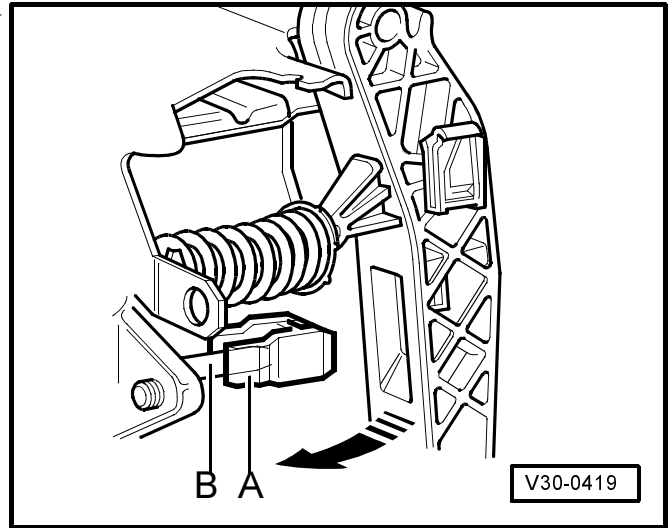

Summary of components - Hydraulics

- 1 - Brake fluid reservoir**
- 2 - Tubing**
- 3 - Master cylinder**
 - removing and installing ⇒ **30-1** page 5
- 4 - Locking clip**
 - remove for tube-hose line ⇒ item 9 pull out from master cylinder up to stop
- 5 - Support**
 - only replace if the master cylinder has been removed ⇒ item 3
 - removing ⇒ Fig. 1 in **30-1** page 5
 - installing ⇒ Fig. 2 in **30-1** page 5
- 6 - Clutch pedal**
 - removing and installing ⇒ **30-1** page 3
- 7 - 25 Nm**
 - always replace
- 8 - O-ring**
 - moisten with brake fluid before installing
- 9 - Tube-hose line**
 - assign following spare parts catalogue
- 10 - Bracket**
 - at front left frame side rails
 - clip on for tube-hose line
- 11 - Bracket**
 - holds the tube-hose line on the gearbox
- 12 - 20 Nm**
- 13 - Locking clip**
 - remove for tube-hose line ⇒ item 9 pull out from slave cylinder up to stop

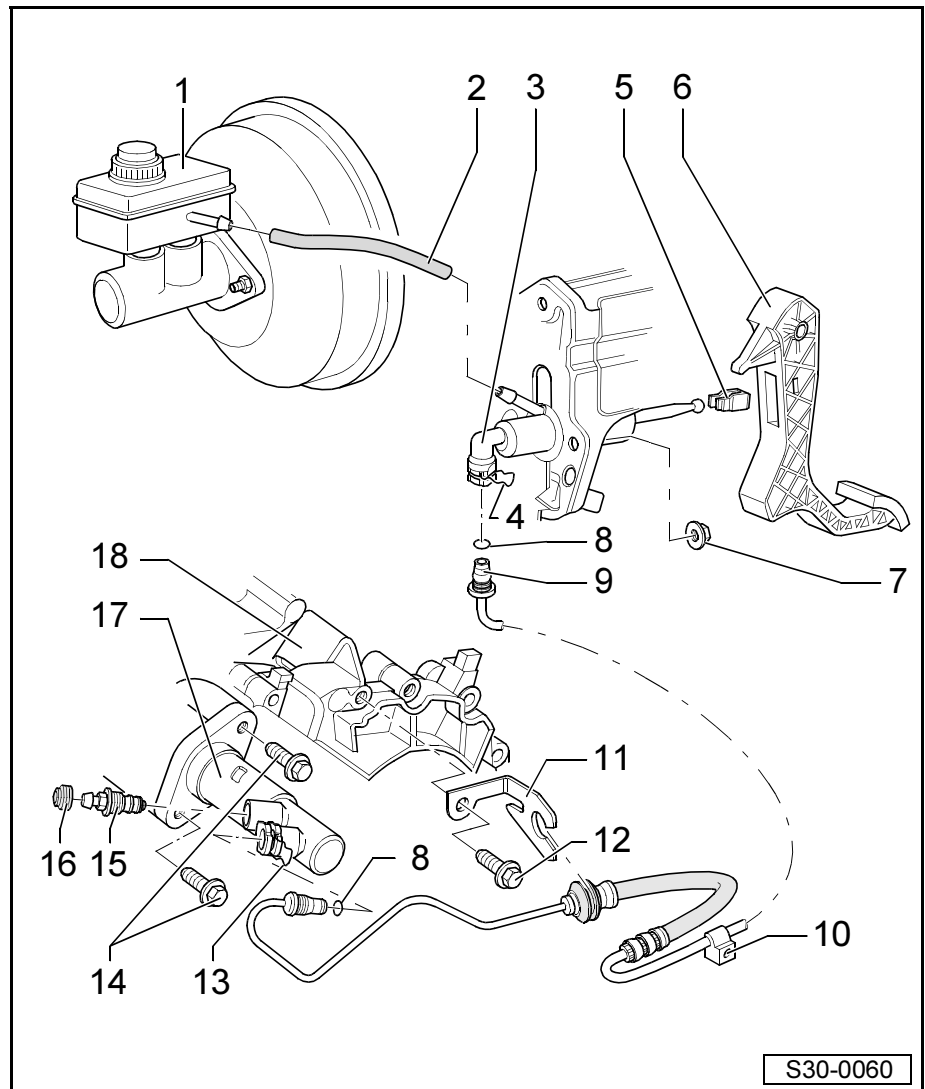

14 - 25 Nm

15 - Vent valve

- ❑ Bleed the clutch system ⇒ **30-1** page 7

16 - Dust cap

17 - Slave cylinder

- ❑ before removing
 - Remove the battery.
 - Remove the collar screws ⇒ item 12.
 - Pull off locking clip up to the stop ⇒ item 13.
 - Disconnect the tube-hose line ⇒ item 9 from the holder ⇒ item 11 and slave cylinder.
- ❑ after installing bleed the clutch system ⇒ **30-1** page 7.

18 - gearbox

Fig. 1: Lever off the support -A- in the direction of the -arrows-

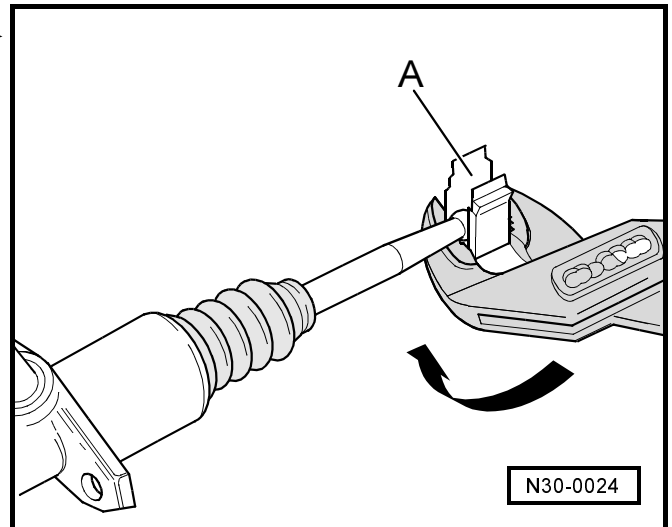
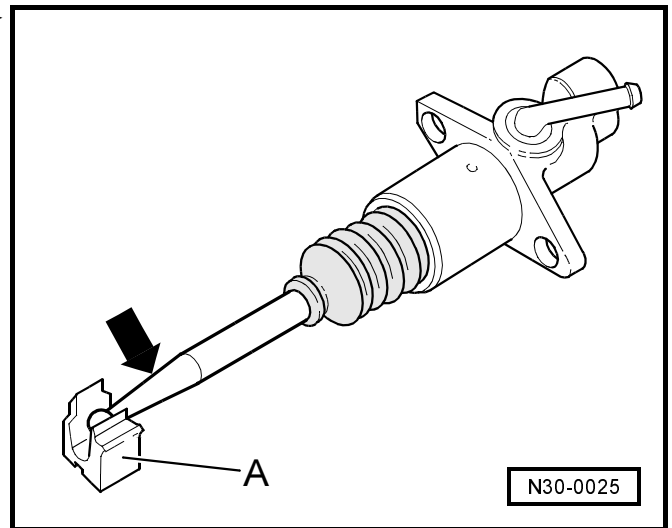

Fig. 2: Push the actuator rod/master cylinder in the support -A- -direction of the arrow-



Removing and installing the master cylinder

Special tools, test and measuring equipment and auxiliary items required

- ◆ Pliers -T10005-

Removing:



Note

Unscrew the master cylinder from within the passenger compartment.

- Release and shut off tubing -A- to the brake fluid reservoir. ▶
- Pull off locking clip -B- from the master cylinder.
- Release and shut off the tube-hose line -C- from the master cylinder.
- Remove the storage area on the driver's side ⇒ Body Work; Rep. Gr. 70.

i Note

To remove the master cylinder completely remove the clutch control. Before removing first separate the master cylinder from the clutch pedal.

Unlock the actuating rod for master cylinder from the clutch pedal as follows:

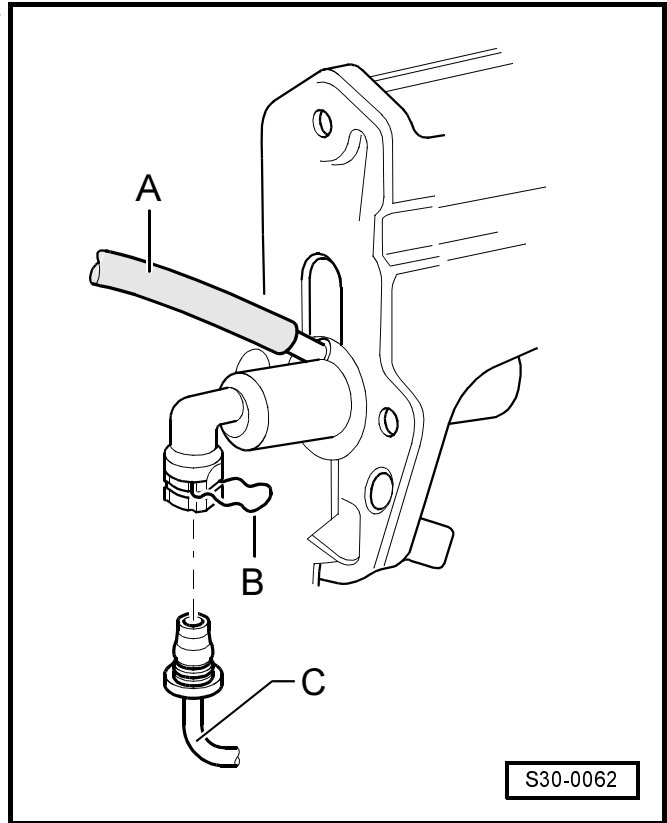

- Insert pliers -T10005- in the clutch pedal recesses. ▶
- Press support and separate the clutch pedal from the master cylinder.

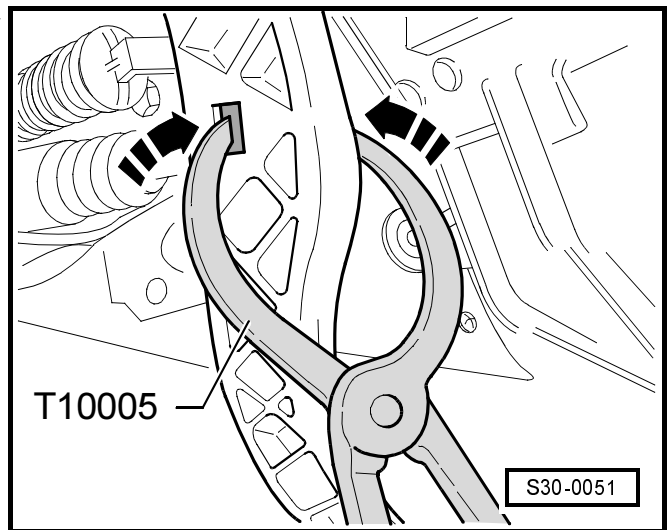

- Unscrew the nuts -arrows 1- and remove the clutch controls -arrow A- together with the master cylinder. ▶
- Removing the over-centre helper spring ⇒ **30-1** page 2.
- Unhook the bearing/over-centre helper spring from the bearing.
- Remove the master cylinder.

Installing:

The installation occurs in reverse order, while paying attention to the following:

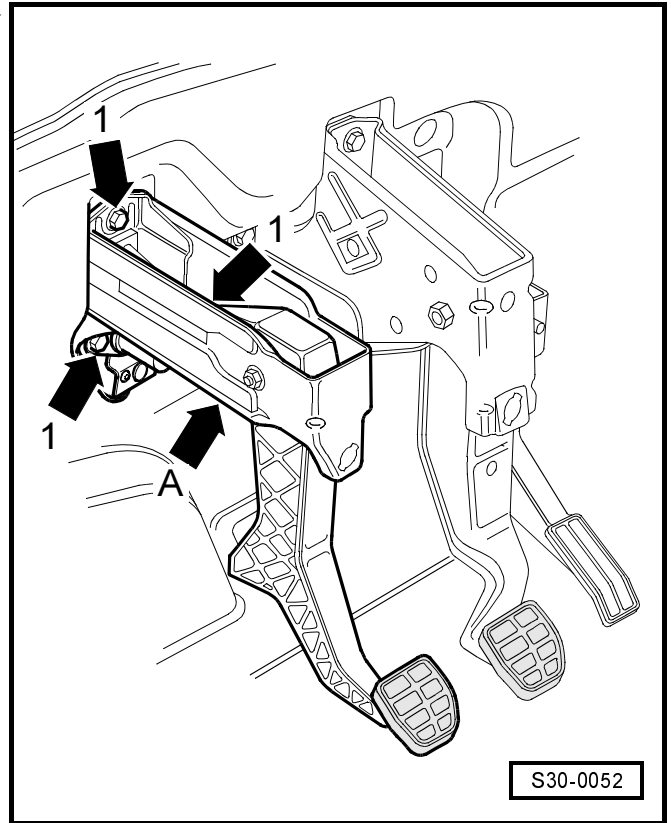

- The support -A- must be located on the actuating rod -B- of the master cylinder. ▶
- To click in the support push the clutch pedal towards the front wall -direction of the arrow- and make sure it catches correctly.
- After installing the master cylinder bleed the clutch system ⇒ **30-1** page 7.

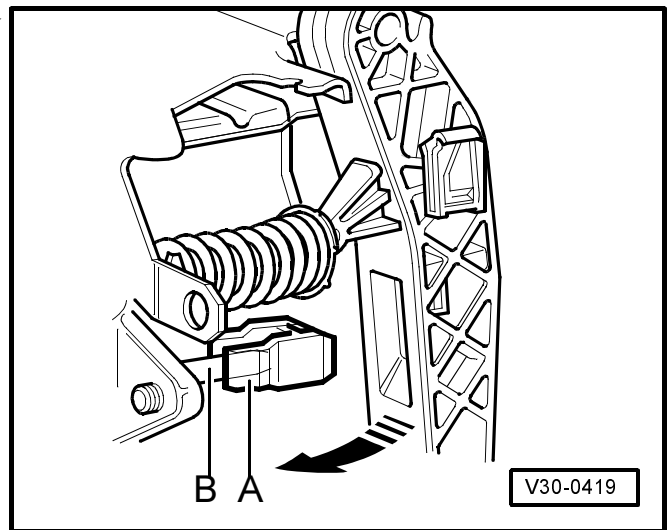

Bleeding the clutch system

Special tools, test and measuring equipment and auxiliary items required

- ◆ Brake filling and bleeding device -ROMESS S15-
- ◆ Ventilation hose -670 mm-

- Bleed the clutch system with brake filling and bleeding device -ROMESS S15-.
- To bleed use ventilation hose - 670 mm-.
- Position the ventilation hose on the supports of the drip bottle of the brake filling and bleeding device -ROMESS S15 -
- Insert the bleeder hose on the slave cylinder -arrow- ▶ and open the bleeder valve.
- After completing the bleeding procedure activate the clutch pedal repeatedly.

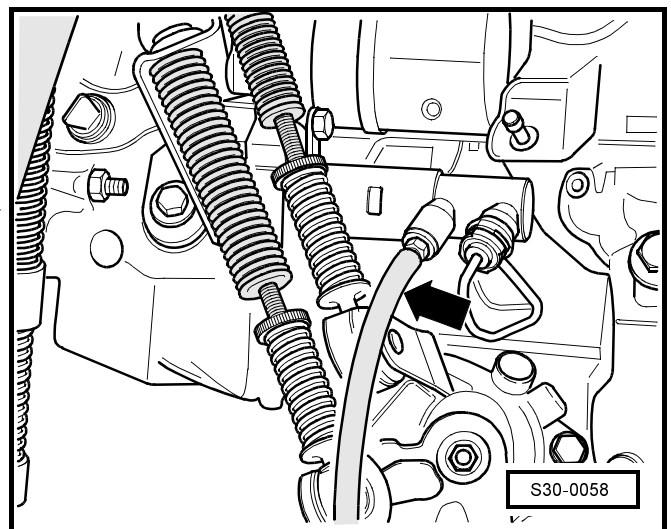

30-2 Removing and installing the clutch control

Special tools, test and measuring equipment and aids required

- ◆ Extractor for valve-stem joint -MP 1-174-
- ◆ Sealant THREE BOND -1324-
- ◆ Grease MoS₂

Note!

Remove and install the clutch release bearing together with the clutch release lever -3- and guide bushing for clutch release bearing -5- in order to avoid damaging the pegs on the clutch release bearing -1-.

1 - Clutch release bearing

- Do not wash the bearing only wipe it clean
- replace noisy bearing
- grease the contact points on the clutch release lever with grease MoS₂
- removing and installing ⇒ Fig. 3 in **30-2** page 2
- remove and install ⇒ Fig. 1 in **30-2** page 2 together with clutch release lever ⇒ item 3 and guide bushing ⇒ Fig. 1 in **30-2** page 2 remove and install ⇒ item 3

2 - 10 Nm

- before installing apply sealant -THREE BOND 1324-

3 - Clutch release lever

- remove and install ⇒ Fig. 1 in **30-2** page 2 ⇒ item 3 remove and install together with clutch release bearing and guide bushing ⇒ item 3

4 - Retaining spring

- attached to clutch release lever

5 - Guide bushing for clutch release bearing

- removing and installing ⇒ Fig. 2 in **30-2** page 2

6 - Gasket ring for drive shaft

- replacing ⇒ Chap. 34-11

7 - Ball stud

- grease with grease MoS₂
- when replacing the clutch housing drive in with tool -MP 1-174- up to stop

8 - Gearbox

9 - 20 Nm

10 - Slave cylinder

- removing and installing ⇒ Chap. 30-1
- grease tappet end of the rod with grease MoS₂

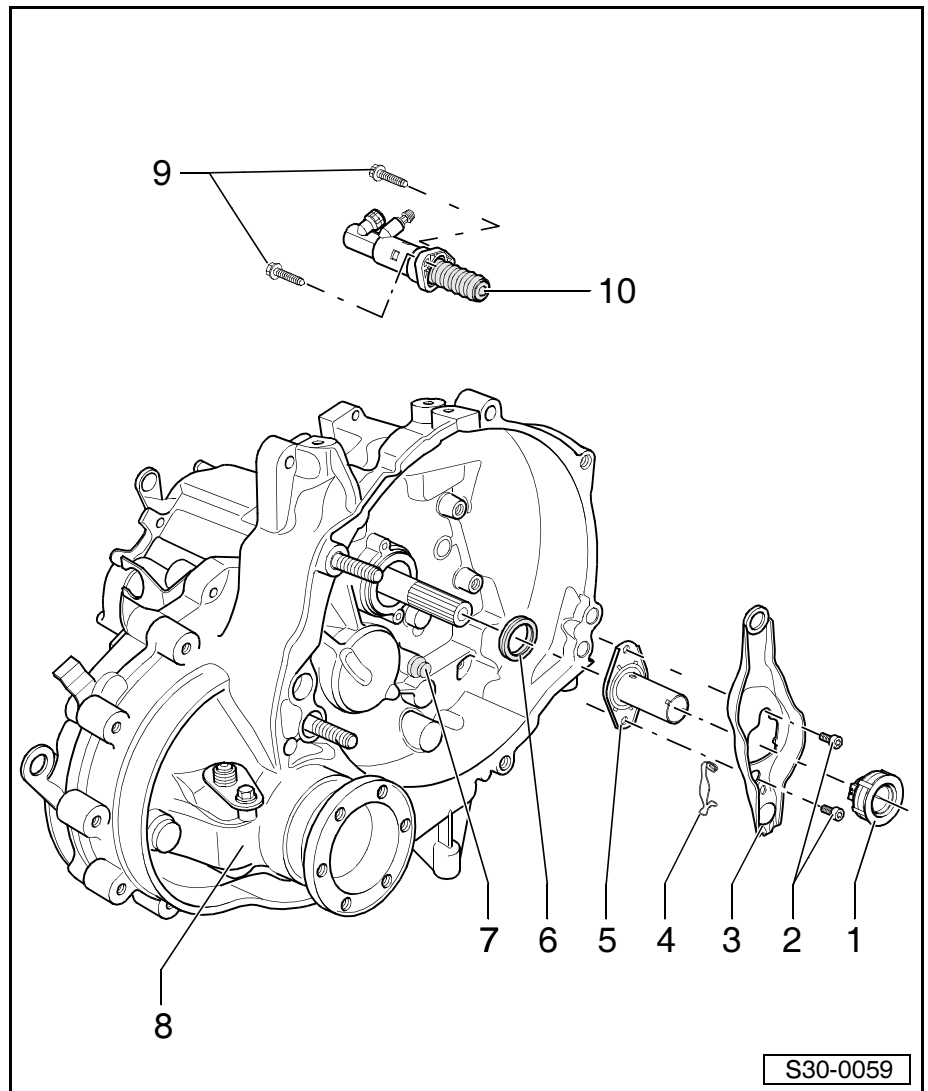

Fig. 1: Removing and installing the clutch release lever with the clutch release bearing and guide bushing for clutch release bearing

- Release screws -arrows-.
- Separate the clutch release lever together with the clutch release bearing and guide bushing for clutch release bearing from the ball stud.

The installation occurs in reverse order.

- Before inserting the screws -arrows- grease with sealant -THREE BOND 1324-.

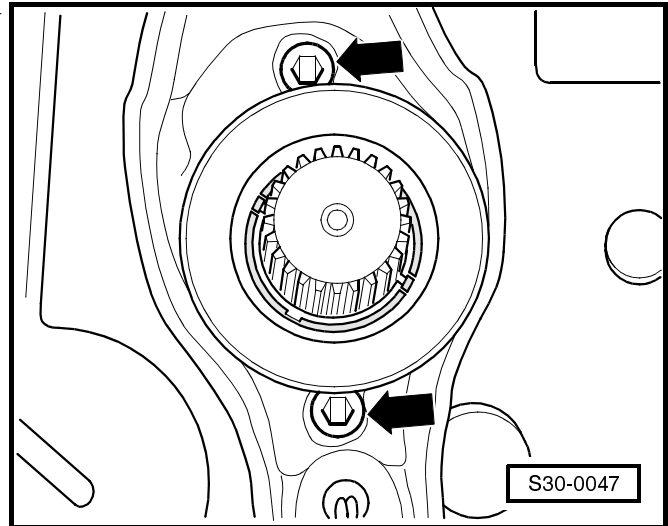

Fig. 2: Removing and installing the guide bushing

- Rotate the guide bushing -3- opposite the clutch release bearing -2- 90° in the direction of the arrow until the catch pegs of the guide bushing fit into the slots -4- of the clutch release bearing.
- In this position remove the guide bushing from the clutch release bearing.

The installation occurs in reverse order.

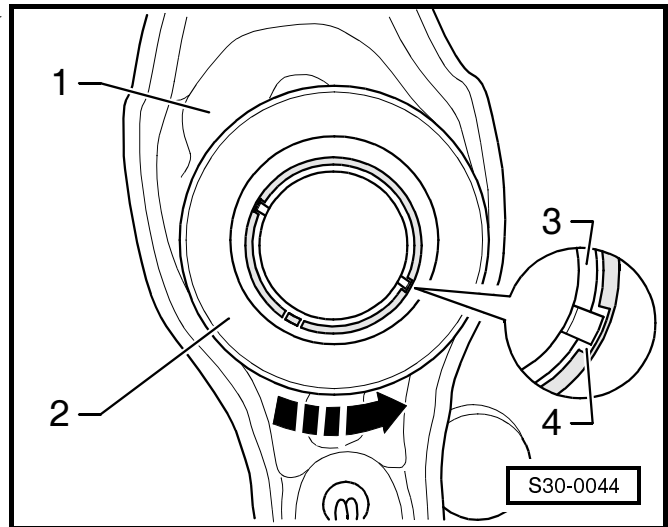

Fig. 3: Removing and installing the clutch release bearing

- Press the catch pegs -arrows- together and remove the clutch release bearing -A- from the clutch release lever.

i Note!

Before installing grease the contact points on the clutch release lever with grease MoS_2 .

- To install press the clutch release lever into the clutch release bearing -A- until the catch pegs -arrows- lock into position.

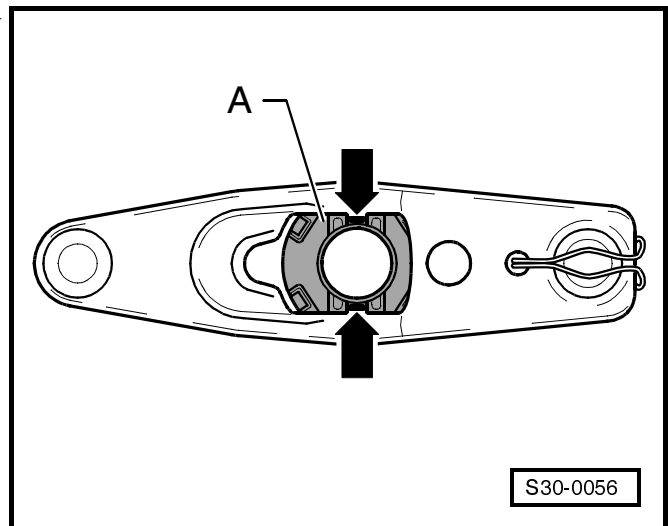

30-3 Repairing the clutch

Special tools, test and measuring equipment and aids required

- ◆ Pressure pad -MP 1-504-
- ◆ Centering mandrel -MP 2-501-
- ◆ Grease -G 000 100-

(Gearbox removed)

Note!

- ◆ Replace the clutch discs and pressure plates if the riveting is damaged or loose.
- ◆ Make the clutch disc and pressure plate coincide in accordance with the spare part catalogue and engine identification characters.

1 - Flywheel

- make sure the centering pins are tight
- The locating face for the clutch lining must be free from grooves, oil and grease
- removing and installing
⇒ Rep. Gr. 13; the relevant engine

2 - Clutch disc

- Diameter ⇒ Chap. 00-1
- Fitting position: the spring cage pointing towards the pressure plate
- center ⇒ Fig. 1 in **30-3** page 2
- slightly grease the serration

Note!

- ◆ Clean the serration on the drive shaft and if the clutch discs have been used clean the hub serration, remove corrosion and only apply a very thin layer of grease SP No.: G 000 100 on the drive shaft serration.
- ◆ Subsequently move the clutch disc up and down on the drive shaft until the hub fits smoothly on the shaft.
- ◆ Remove all excess grease.

3 - Pressure plate

- removing and installing
⇒ Fig. 1 in **30-3** page 2
- Check the extremities of the membrane spring ⇒ Fig. 3 in **30-3** page 2

Note!

The pressure plates are protected against corrosion and are greased. Only clean the thrust surface as otherwise the life of the clutch may be considerably reduced.

4 - 25 Nm

- removing and installing ⇒ Fig. 2 in **30-3** page 2

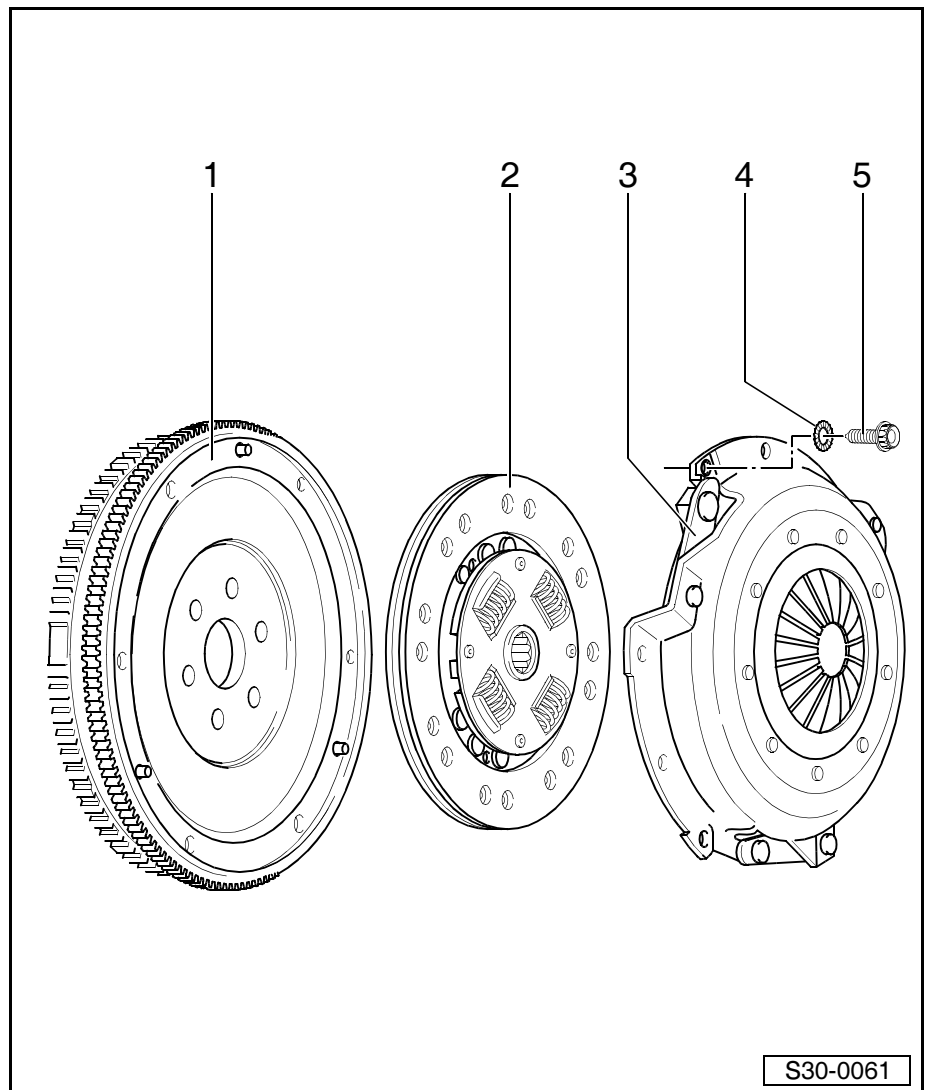

Fig. 1: Center the clutch disc and remove and install the pressure plate

i Note!

The thrust surface of the pressure plate and the clutch disc lining must fully rest against the flywheel. Only then may the fixing screws be inserted. Never tighten the pressure plate in the opposite direction. This could damage the centering holes on the pressure plate and the centering pin of the flywheel.

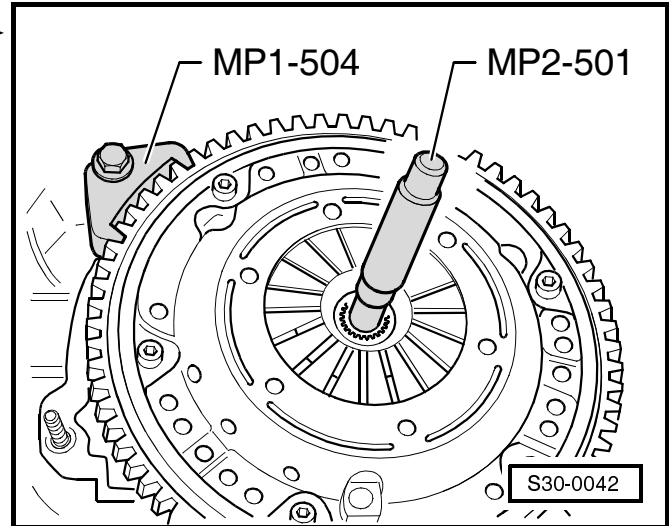

Fig. 2: Tighten gradually in the prescribed sequence.

- Tighten screws -1- through -6- by hand.
- Tighten the screws in the prescribed sequence 1 - 3 - 5 - 2 - 4 - 6 in 3 steps (5 Nm, 15 Nm, 25 Nm).
- Remove clutch mandril -MP 2-501- and release bearing -MP 1-504-.

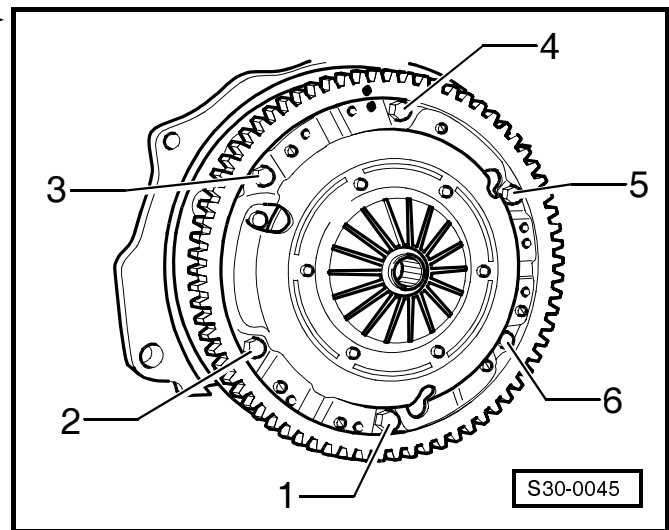
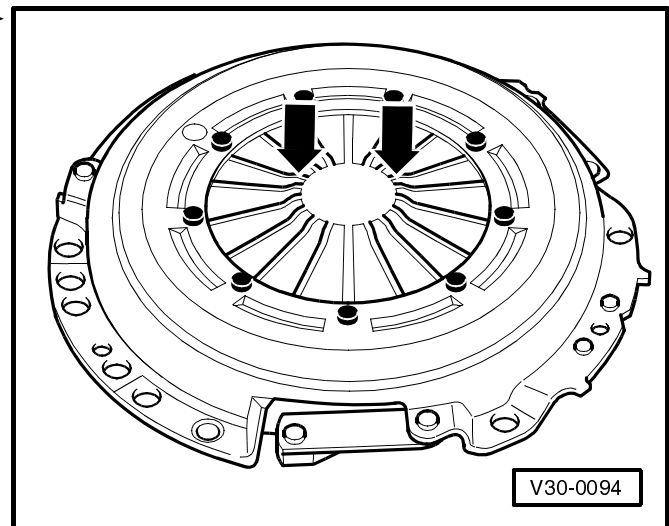

Fig. 3: Check the extremities of the membrane spring

- Wear is allowed up to half the membrane spring thickness.



34 – Control, housing

34-1 Shift mechanism

Fitting location of shift mechanism

- A - Shift cable for shift movement
- B - Selector cable for selector movement
- C - Heat shield
 - take off before removing the shift mechanism

Pfeil A- Shift movement

Pfeil B- Selector movement

1 - Gearshift lever

2 - Reversing lever

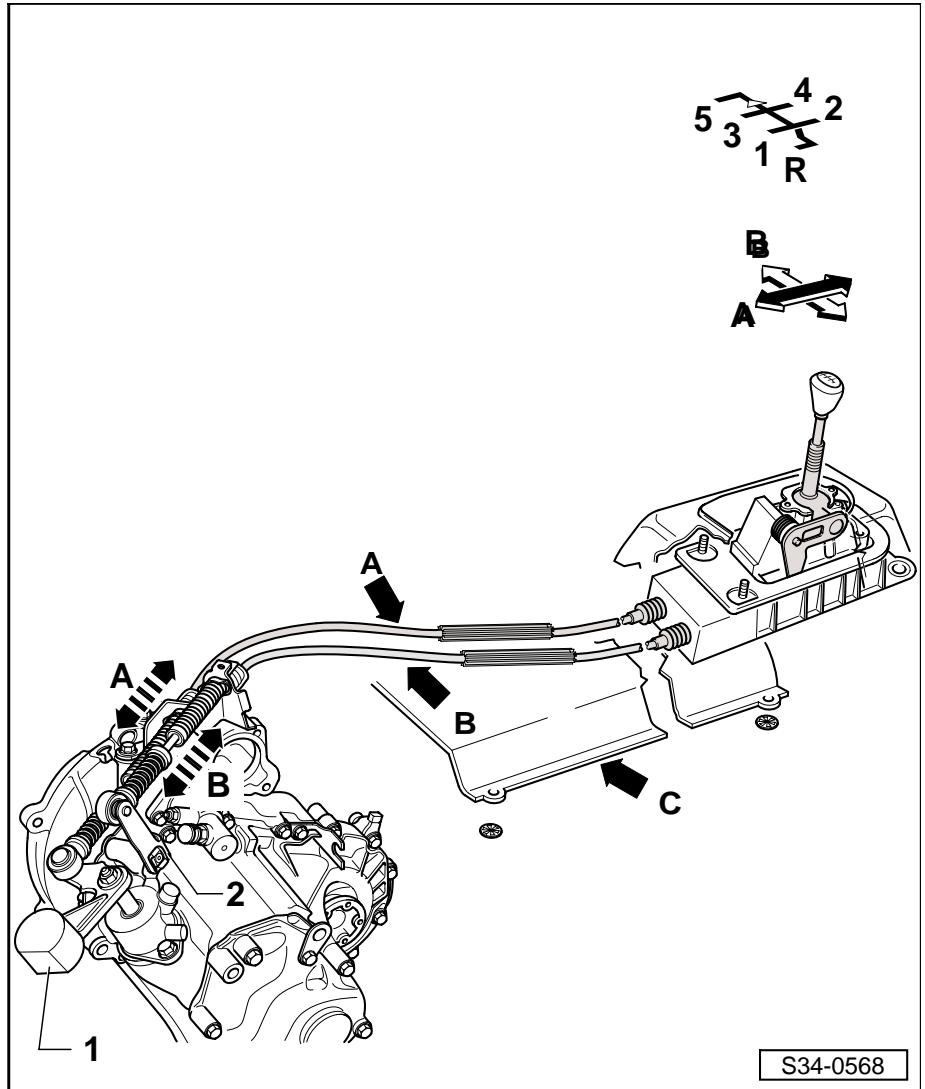

i Note

- ◆ Disconnect earth strap at battery before carrying out work in the engine compartment.
- ◆ Before disconnecting the battery determine the code of radio sets fitted with anti-theft coding.
- ◆ If the battery earth strap is disconnected and connected, carry out additional operations ⇒ *Electrical System; Rep. Gr. 27.*
- ◆ Remove shift mechanism for replacing control cables ⇒ *Chap. 34-5.*
- ◆ Do not buckle the control cables.

**I - Gearshift knob and cover -
Summary of components
⇒ Chap. 34-2**

**II - Shift lever and shift housing -
Summary of components
⇒ Chap. 34-3**

**III - Control cables - Summary of
components ⇒ Chap. 34-4**
Removing and installing shift
mechanism ⇒ Chap. 34-5
Setting shift mechanism
⇒ Chap. 34-6

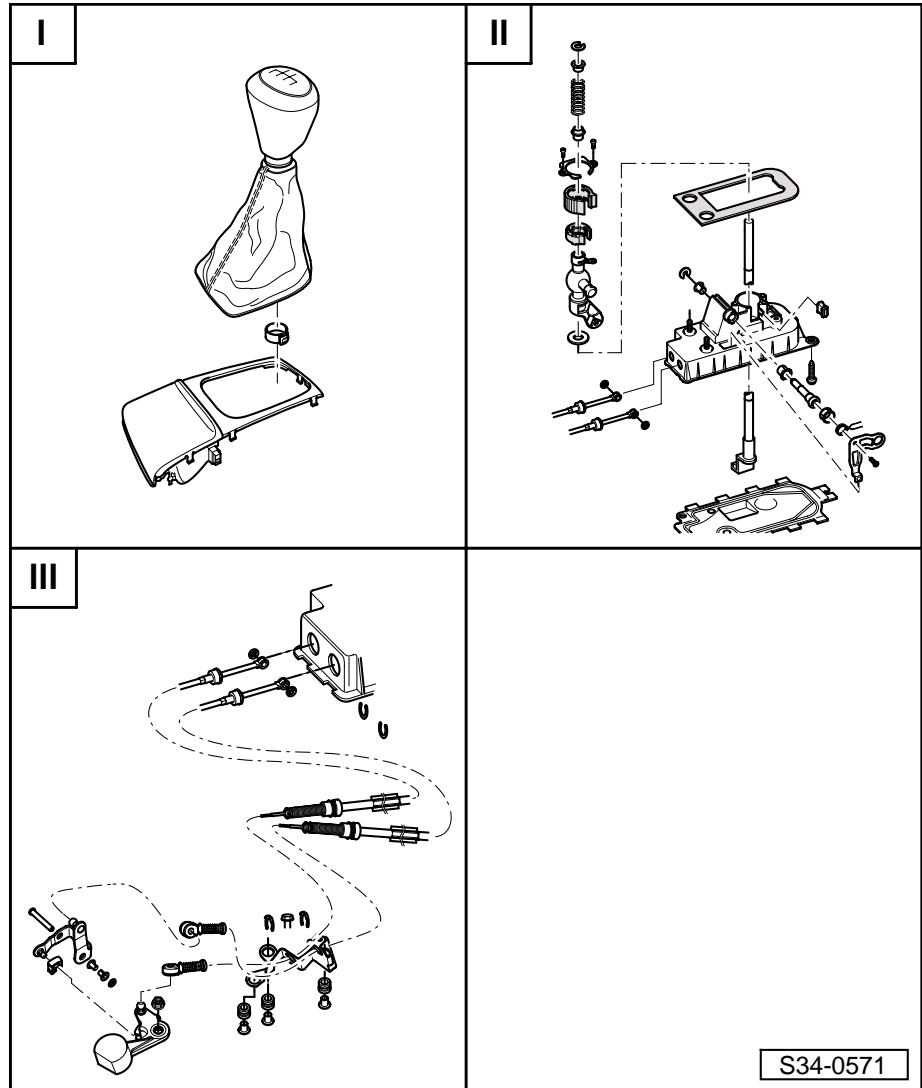

34-2 I - Gearshift knob and cover - Summary of components

1 - Gearshift knob

- with collar
- It is not possible to separate the gearshift knob from the collar
- always replace together
- removing and installing
⇒ **34-2** page 2

2 - Collar clamp

- for securing the gearshift knob to the gearshift lever

3 - Surround of centre console

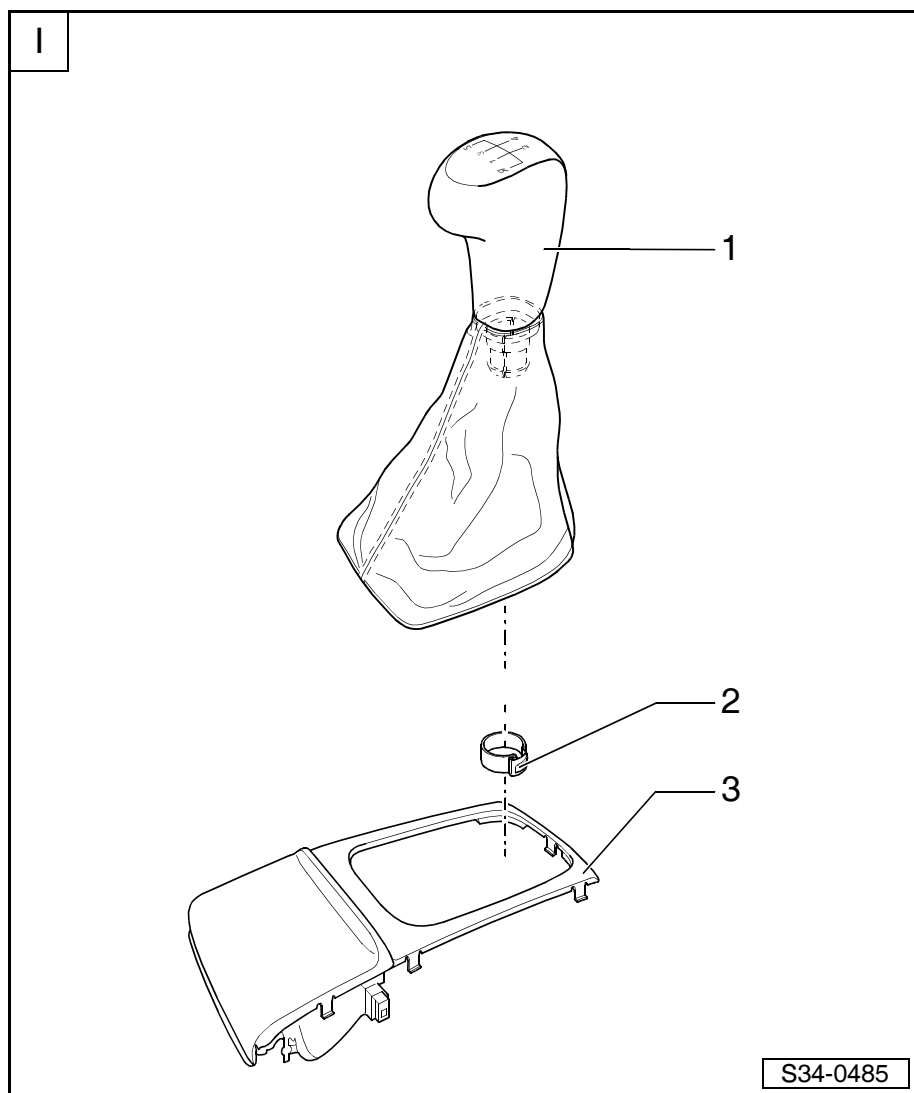

Separating collar from gearshift lever

- Lever the collar out of the surround of centre console -arrows- ▶
- Pull the collar upwards over the gearshift knob.

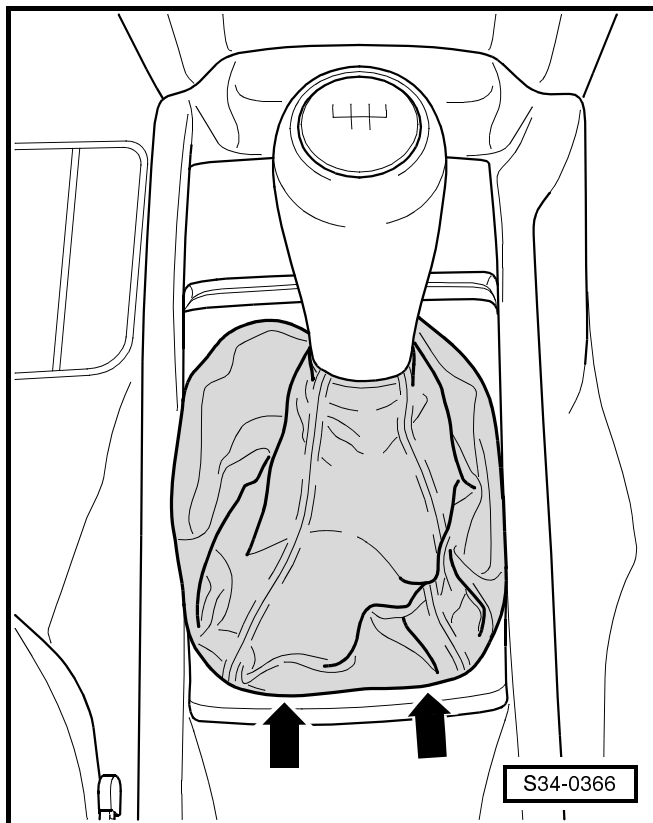

- Open clamp -arrow- and pull off gearshift knob together with the collar. ▶

Installing

- Turn collar inside out.
- Install gearshift knob, join together collar and collar clamp -arrow-.

When positioning the gearshift knob on the gearshift lever the gearshift knob must lock into the round slot of the gearshift lever.

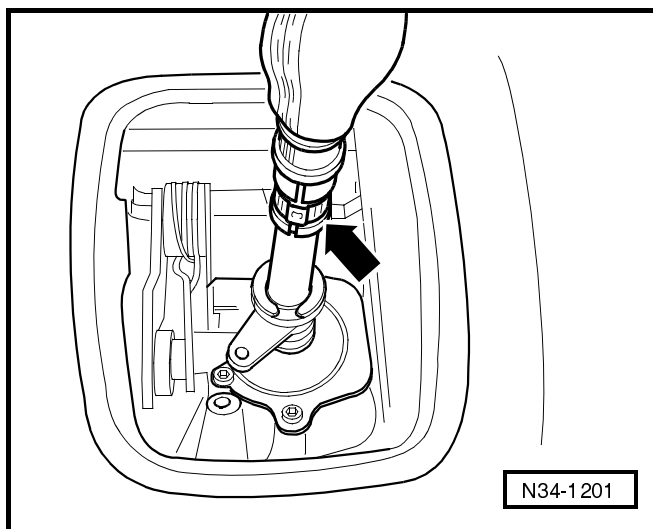

34-3 Assembly Overview – Shift Lever and Shift Housing



Note!

Grease bearing points and contact surfaces with poly resin grease -G 052 242 A2-.

- 1 - Circlip**
 - removing and installing
⇒ Fig. 1 in **34-3** page 2
- 2 - Bush**
- 3 - Compression spring**
- 4 - Bush**
- 5 - 5 Nm**
- 6 - Cover**
- 7 - Bearing shell**
- 8 - Insulation**
- 9 - Shift lever guide**
- 10 - Insulating washer**
- 11 - Gasket**
 - between shift housing and body
 - self-adhesive
 - stick onto shift housing
- 12 - Shift lever**
- 13 - Insulation**
- 14 - Shift housing**
- 15 - Bearing bush**
- 16 - 25 Nm**
- 17 - Bearing pin**
- 18 - Guide bush**
- 19 - Compression spring**
 - installing ⇒ Fig. 2 in **34-3** page 2
- 20 - Selector lever**
- 21 - 5 Nm**
- 22 - Floor plate**
 - bend up tabs for removing
 - replace
- 23 - Selector cable**
 - at selector angle plate
 - fitting location ⇒ Chap. 34-1
- 24 - Shift cable**
 - press onto shift lever guide
 - fitting location ⇒ Chap. 34-1
- 25 - Circlip**
- 26 - 25 Nm**
- 27 - Bearing bush**
 - fits only in one position
- 28 - Circlip**

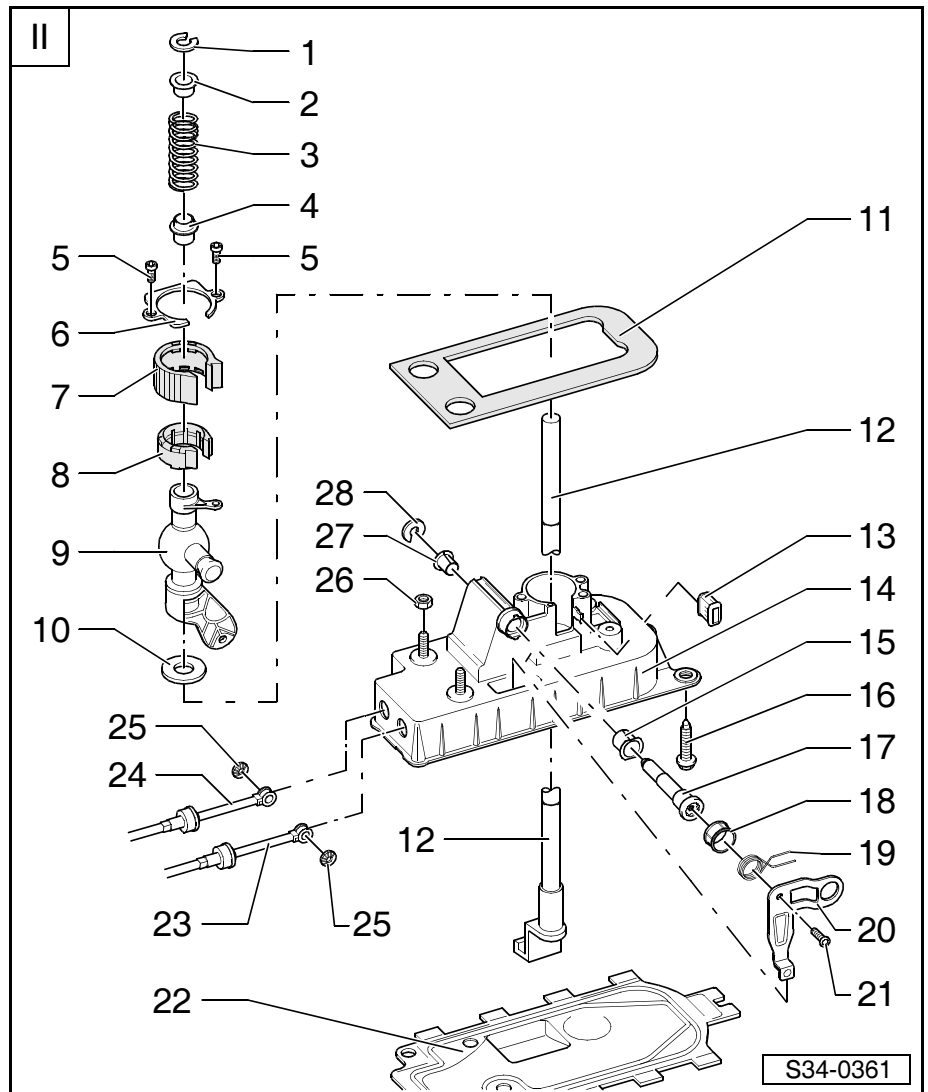
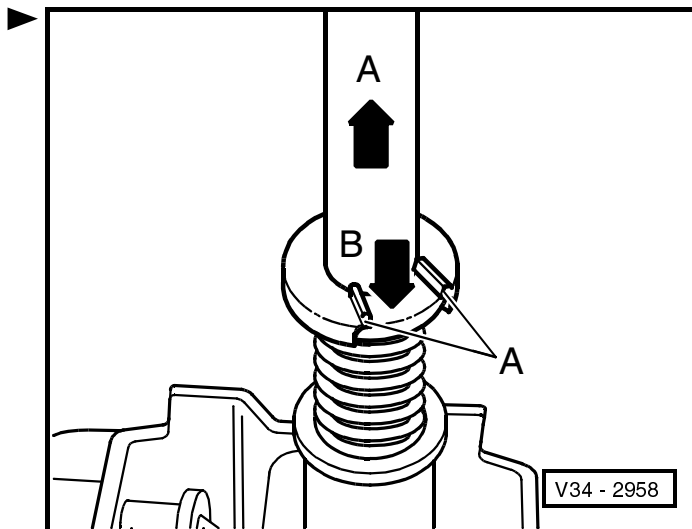

Fig. 1: Removing and installing circlip

- To remove and install the circlip -A-, pull shift lever in direction of arrow -A- and at the same time use a screwdriver to press down bush in direction of arrow -B- as far as the stop.

i Note!

- ◆ Do not twist bush when pressing down.
- ◆ Mounting slot in shift lever for circlip must be visible.
- ◆ Release spring carefully

**Fig. 2: Installation of compression spring**

- Insert the compression spring so that the leg -A- is positioned above the stud -arrow-.
- After this, pull the web -B- down far enough so that it moves underneath the stud -arrow-.

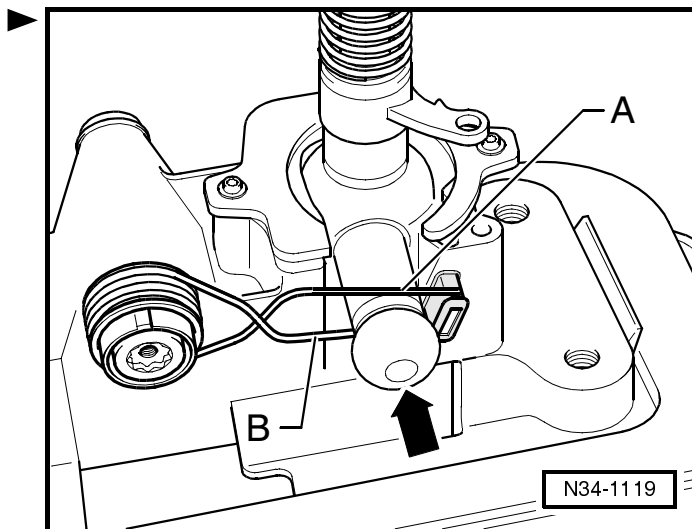

34-4 Assembly Overview – Control Cables



Note!

Grease bearing points and contact surfaces with poly resin grease -G 052 242 A2-.

- 1 - Shift cable**
 - press onto shift lever guide
 - fitting location ⇒ Chap. 34-1
- 2 - Selector cable**
 - at selector angle plate
 - fitting location ⇒ Chap. 34-1
- 3 - Circlip**
- 4 - Circlip**
 - do not damage cables when removing
- 5 - Shift housing**
- 6 - Support**
- 7 - Grommet**
 - mounting of support to gear-box
- 8 - Spacer**
- 9 - 25 Nm**
 - 3 in total
 - for support
- 10 - Cable lock**
 - for selector cable at relay lever
- 11 - Cable lock**
 - for shift cable at gearbox shift lever
- 12 - Circlip**
- 13 - Bearing bush**
- 14 - Relay lever**
 - fitting location ⇒ Fig. 1 in **34-4** page 2
- 15 - Bearing pin**
 - for relay lever
- 16 - Sliding shoe**
- 17 - Gearbox shift lever**
 - with balancing weight
 - insert so that the interrupted spacing of the teeth matches the shift shaft
 - after installing, set shift mechanism ⇒ Chap. 34-6
 - fitting location ⇒ Fig. 1 in **34-4** page 2
- 18 - 25 Nm**

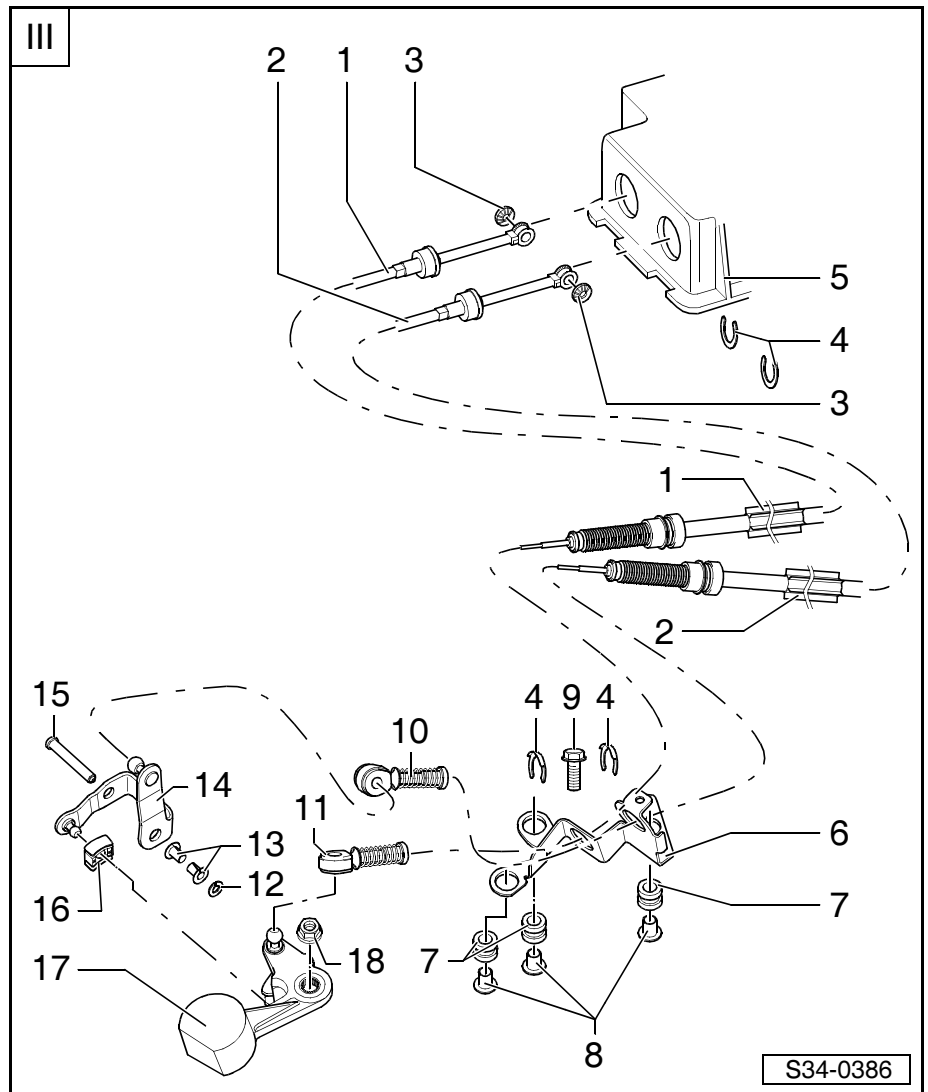
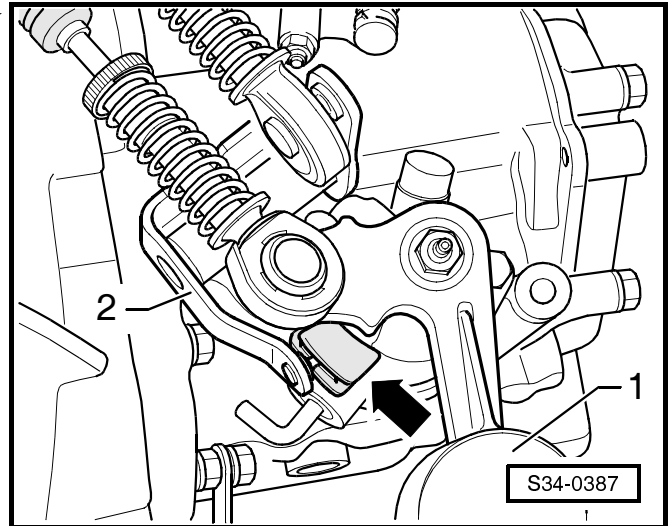

Fig. 1: Fitting location of gearbox shift lever/relay lever ▶

- 1 - Gearbox shift lever with balancing weight
- 2 - Relay lever is inserted over the sliding shoe into the sliding rail of the gearbox shift lever -arrow-



34-5 Removing and Installing Shift Mechanism

Removing

- Before disconnecting the battery, determine the radio code of radio sets fitted with anti-theft coding.
- Switch off ignition and disconnect earth strap at battery.
- Remove battery and battery tray => Electrical System; Rep. Gr. 27.
- Use an open-end wrench to lever off selector cable -A- and shift cable -B- at gearbox. ▶
- 1 - Open-end wrench size 13, commercially available
- Detach cable support from gearbox -arrows-. ▶

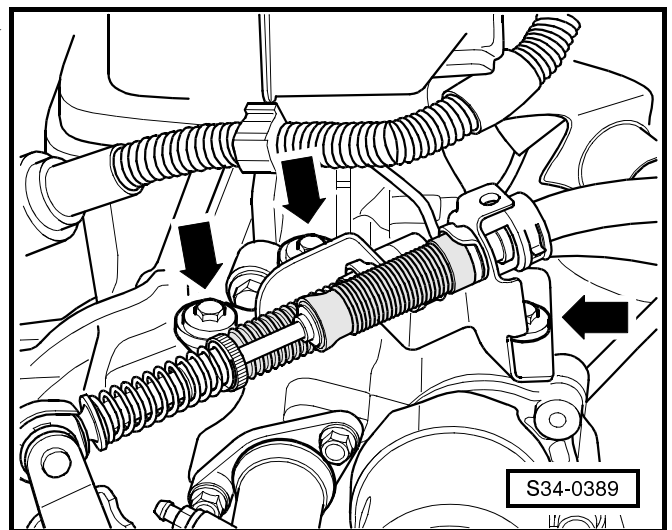
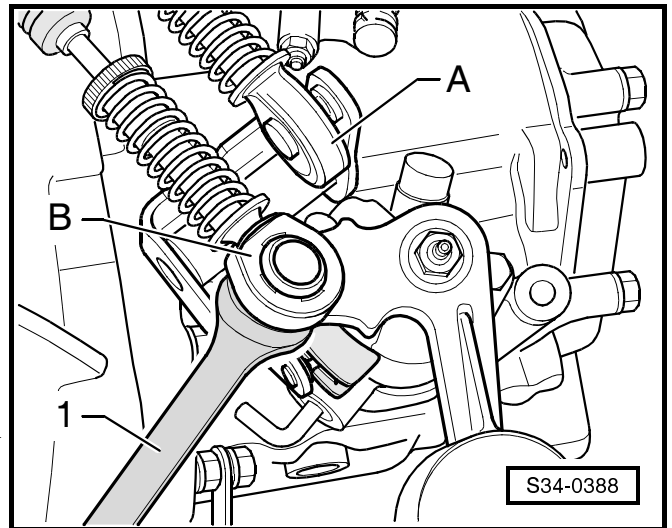

- Lever cover up and out of the surround for the centre console -arrows-. ▶
- Fold cover up and over gearshift knob.

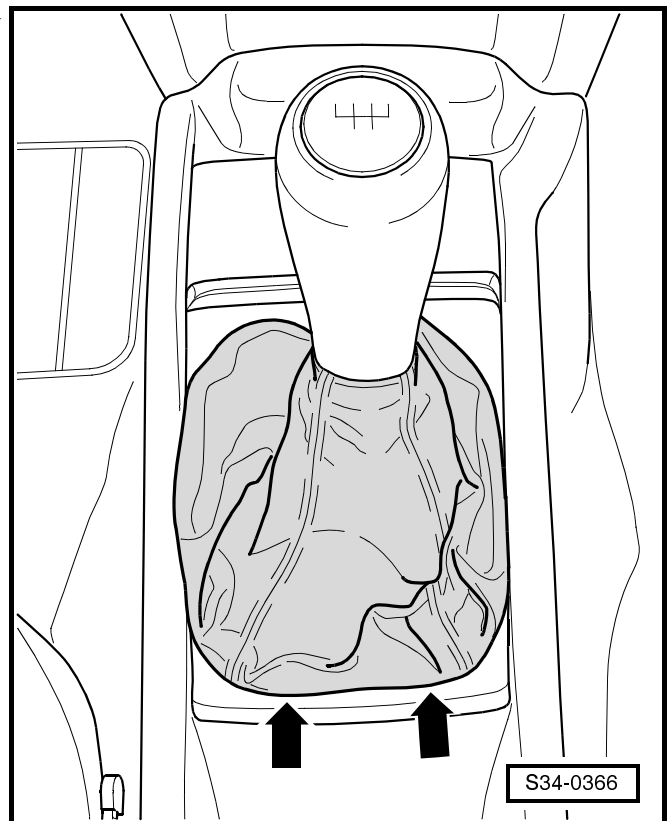

- Open clamp -arrow- and pull off gearshift knob together with the cover. ▶
- Remove surround for centre console ⇒ Body Fitting Work; Rep. Gr. 70.

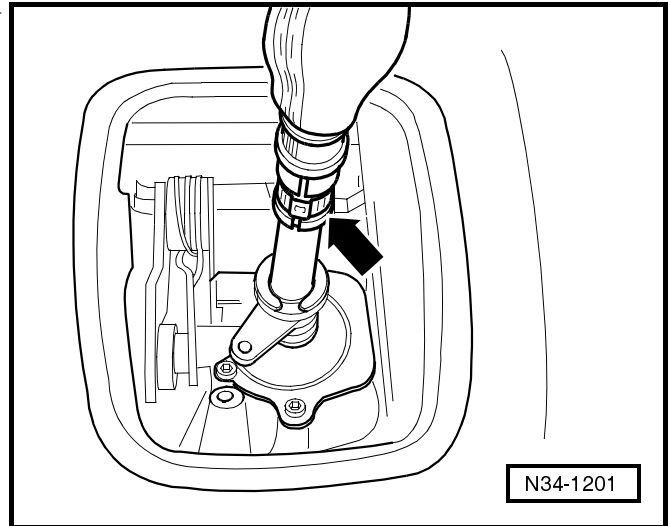

- Unscrew front nuts -arrows- attaching the shift housing. ▶

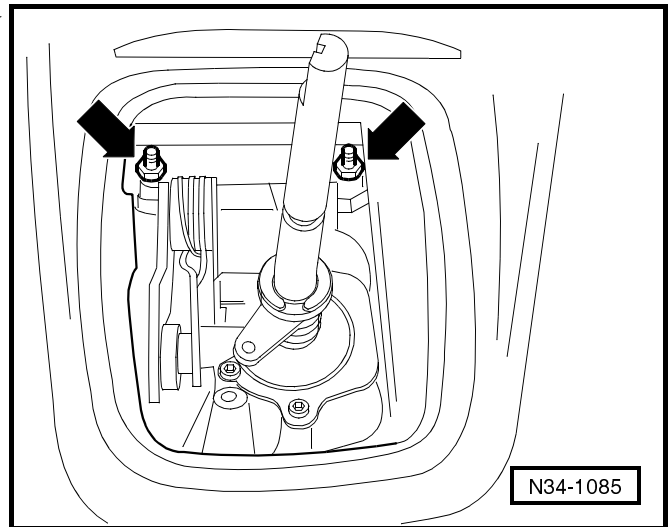

- Detach bracket -1- below the exhaust system. ▶
- Separate exhaust system at the double clamp -2-.
- Unbolt bracket -3- for rear exhaust pipe.
- Unbolt front bracket of body.
- Remove heat shield -4-.
- Unbolt shift housing from body.

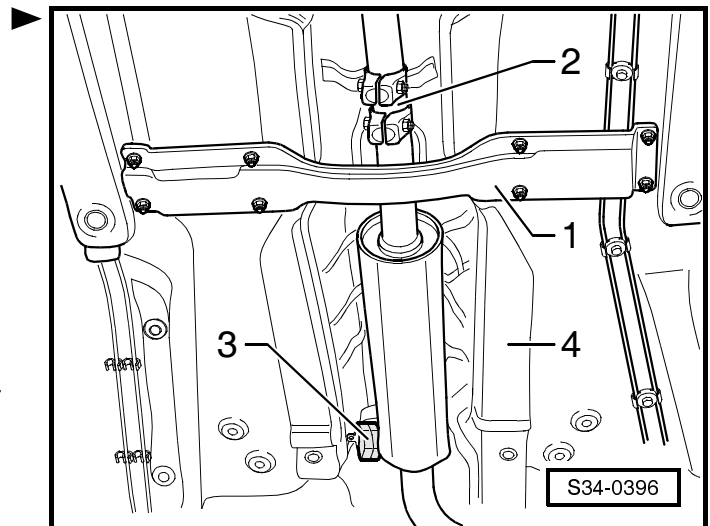

Installing

Installation is carried out in the reverse order. Pay attention to the following point:

- Pack a small quantity of poly resin grease into the ball socket of the shift cable lock -A- and of the selector cable lock -B-.

i Note!

The seal -arrows- outside of the ball socket must be free of grease.

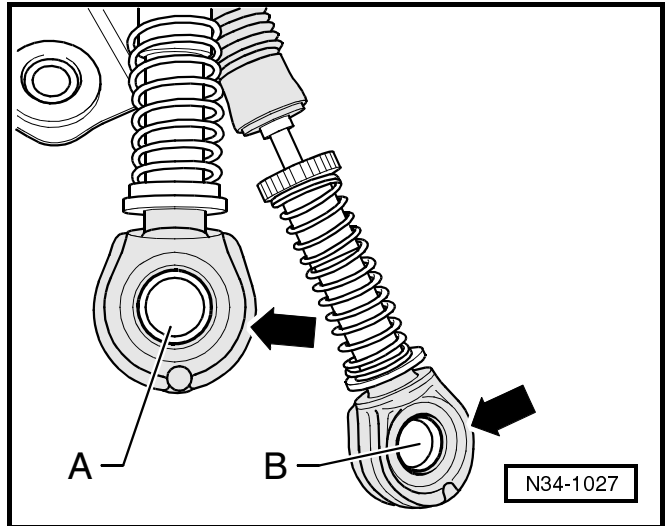

- Press the shift cable onto the gearshift lever and the selector cable onto the relay lever -arrows-.

Setting shift mechanism ⇒ 34-6.

Tightening torques

Components	Tightening torque
Shift housing to body	25 Nm
Front bracket to body	25 Nm
Rear bracket to body	25 Nm
Cable support to gearbox	25 Nm

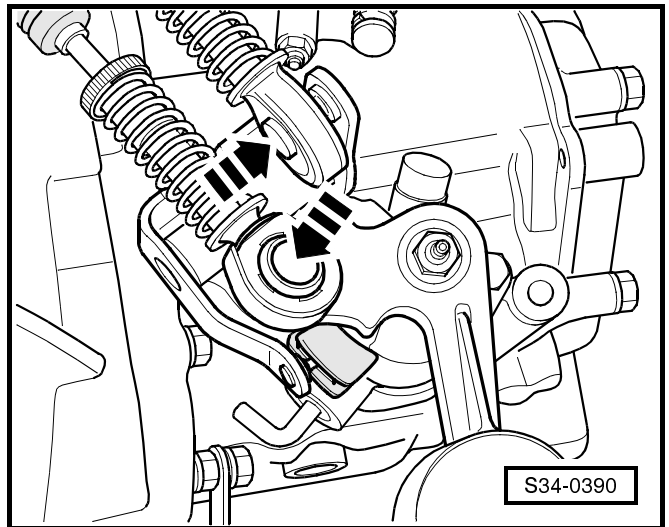

34-6 Setting Shift Mechanism

Special tools, test and measuring equipment and auxiliary items required

- ◆ Locking pin -T10027-

Note!

- ◆ The following points are requirements for correct setting of the shift mechanism:
- ◆ Operating and transmission elements of the shift mechanism are in proper condition.
- ◆ Shift mechanism operates freely.
- ◆ Gearbox, clutch and clutch control must be in proper condition.

- Gearbox in Neutral.

- Detach intake connection of air filter ⇒ 1.0/37; 1.4/50 Engine, Fuel Injection; Rep. Gr. 24.
- Pull locking mechanism at shift cable and at selector cable forward as far as the stop -arrow 1- and then lock by turning to the left -arrow 2-.

Lock the shift shaft as follows:

- Press the shift shaft down -direction of arrow 1-.
- When pressing down the shift shaft, turn the angle lever -A- in direction of -arrow 2-.

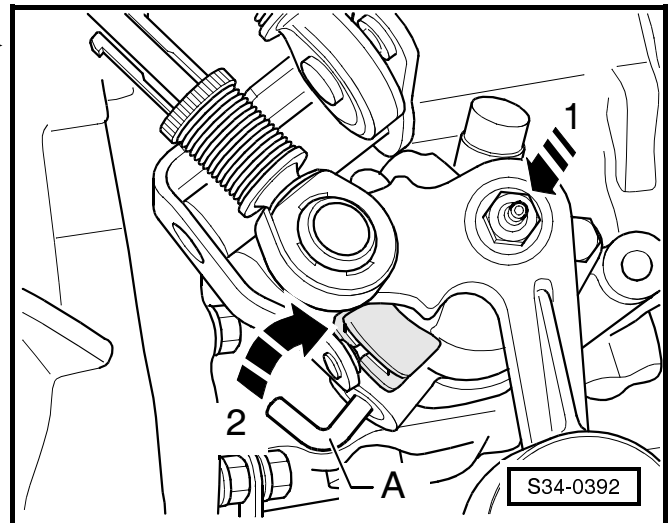
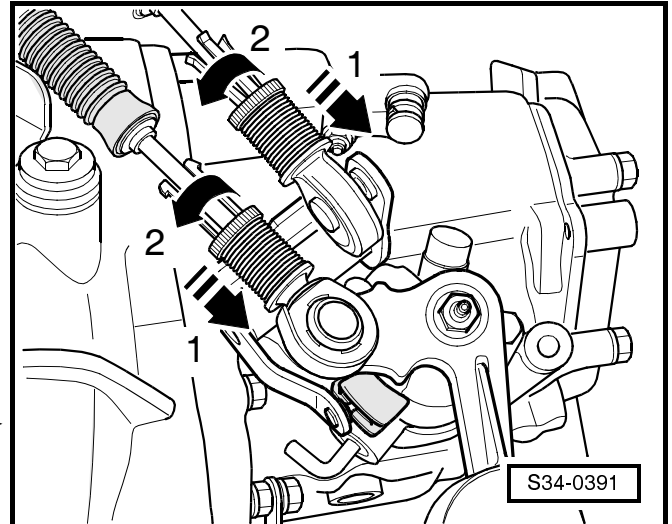

- Lever cover up and out of the surround for the centre console -arrows-.
- Guide shift lever in Neutral to the left into the gate of 1st/2nd gear.

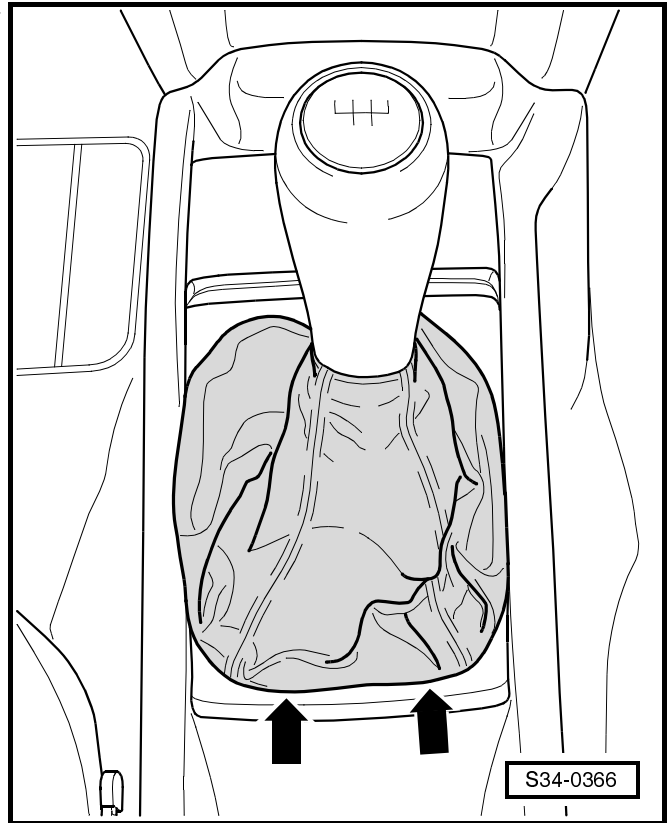

- Insert the locking pin -T10027- through the hole -A- into the hole -B-.

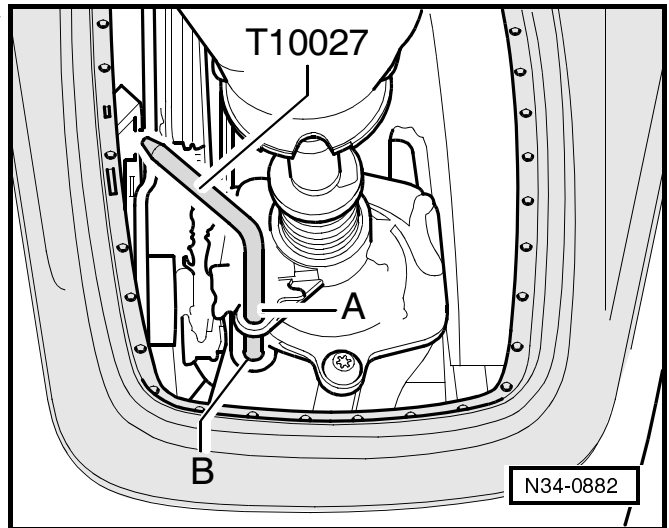

- Now, turn the locking mechanism at the shift cable and at the selector cable to the right as far as the stop -direction of arrow-.

The spring pushes the locking mechanism into the initial position.

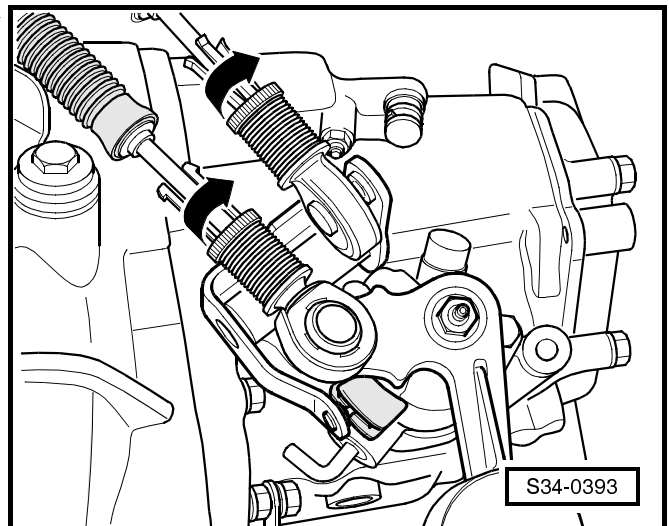

- Now, turn the angle lever -A- back into the initial position -direction of arrow-.

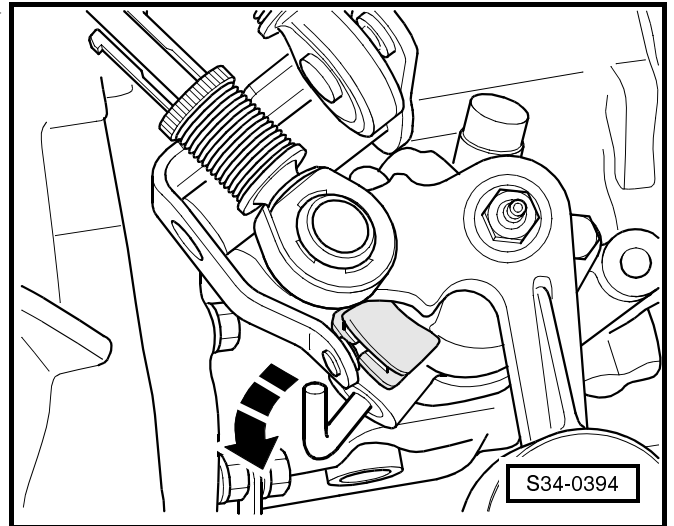

- Pull the locking pin -T10027- out of the holes -A- and -B-.
- Fit cover into the surround for centre console.

Function

- Shift lever must be positioned in Neutral in the gate of 3rd/4th gear.
- Depress clutch.
- Shift through all gears several times. Pay particular attention to proper operation of the reverse gear lock.

If the gearshift lever catches when repeatedly engaging a gear, check the play (stroke) of the shift shaft as follows:

- 1. Engage 1st gear.
- Push shift lever fully to the left and release again.
- At the same time, observe the shift shaft at the gear-box (2nd person).
- When the gearshift lever is moved, the shift shaft must make a stroke of about 1 mm -direction of arrow-.
- If this is not the case, set shift mechanism ⇒ **34-6** page 1.

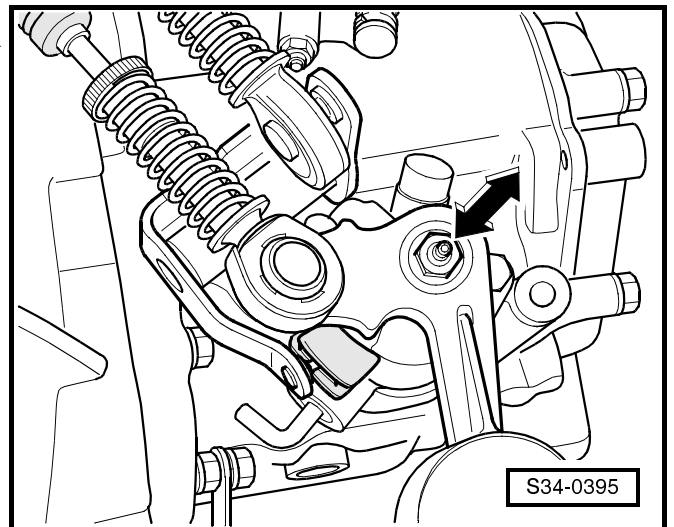
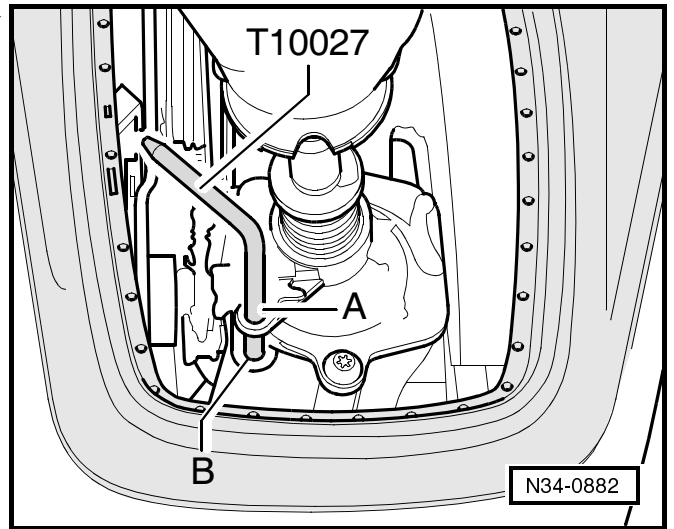

34-7 Removing and installing the gearbox

Removing

Special tools, test and measuring equipment and auxiliary items required

- ◆ Threaded part -3114/2-
 - ◆ Gearbox mount -3282-
 - ◆ Adjusting plate -T30018-
 - ◆ Engine/gearbox jack (e.g. -V.A.G 1383 A -)
 - ◆ Transport device -MP 3-478-
 - ◆ Supporting device -MP 9-200-
 - ◆ Grease -G 000 100-
- Remove the engine trim panel.
 - Remove the air filter of the relevant engine; Rep.-Gr. 24.
 - Before disconnecting the battery determine the code of radio sets fitted with anti-theft coding.
 - Disconnect the earth strap from the battery with the ignition off.
 - Remove the cable from the starter solenoid switch ⇒ Electrical System; Rep. Gr. 27.
 - Remove battery and battery tray ⇒ Electrical System; Rep. Gr. 27.
 - Release nut -arrow A- and tie up holder -1-. ▶
 - Remove engine speed sender -G 28- -arrow B-. ▶
 - Disconnect the Bowden cable support from gearbox -arrows-. ▶

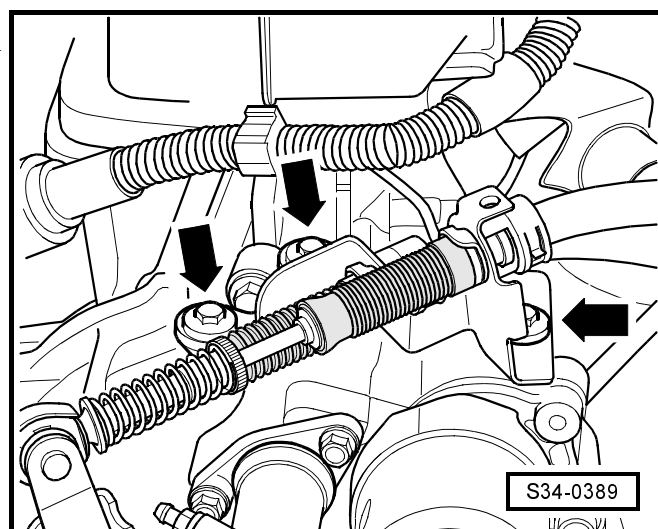
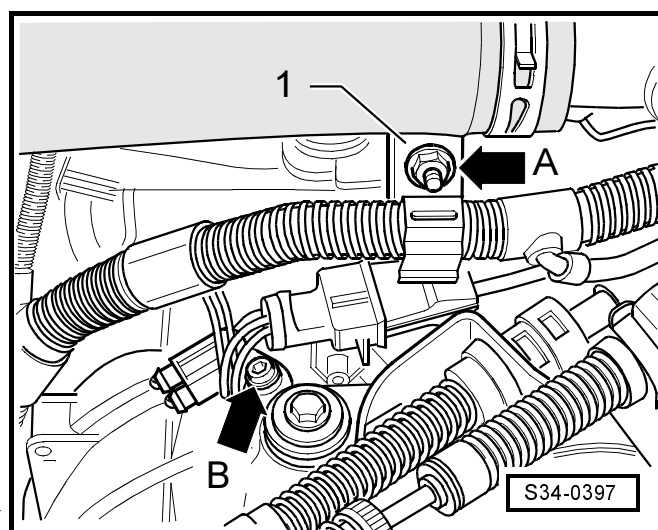

- Remove selector cable -A- with relay lever. To do so remove the circlip -arrow 1- from the relay lever.
- Remove bearing bolt -arrow 2 - from the reversing lever of the selector cable -A-.
- Remove the shift cable -B- with the gearshift lever. To do so unscrew nut -arrow 3-.
- Remove the starter => Electrical System; Rep. Gr. 27.

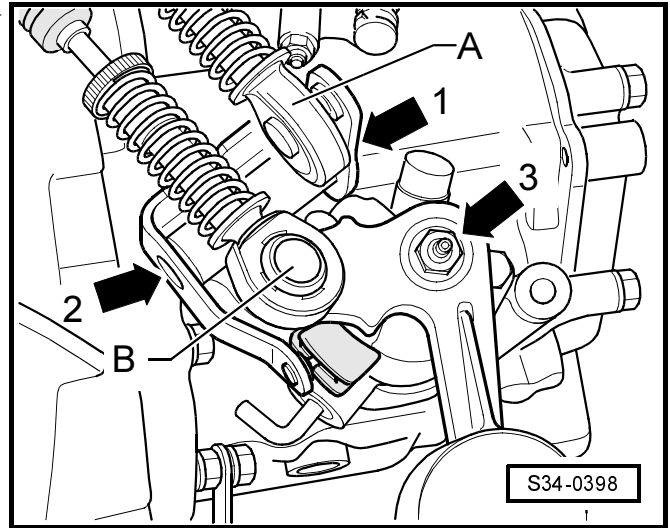

- Unplug connector -arrow- from speedometer sender -G 22-.

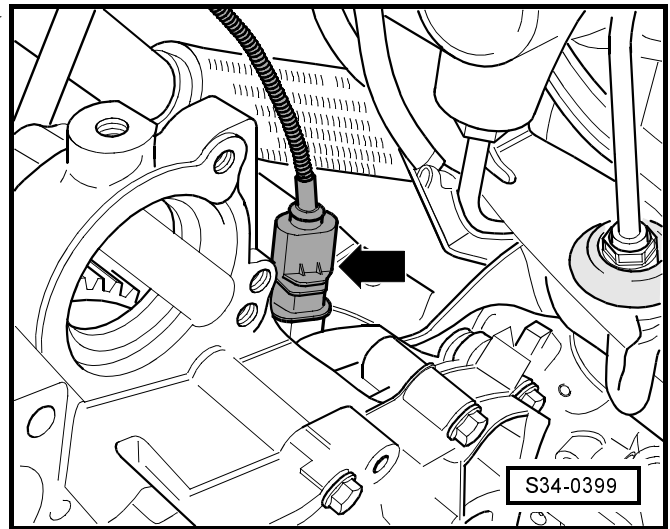

- Remove the hose line holder -1- from the gearbox -arrow A-.
- Remove -2- the slave cylinder -arrow B- and lay aside, secure with wire. Do not open line system.

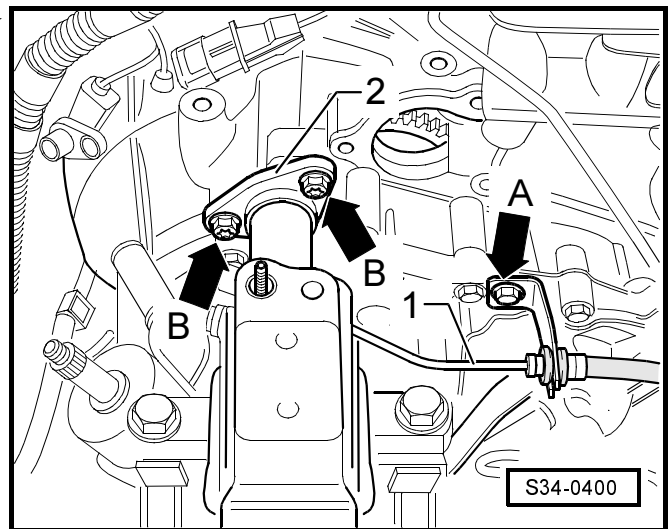

⚠ Caution!
Do not depress the clutch pedal.

- Unscrew nuts from the studs accessible from the top and release the engine/gearbox connecting screw.
- Remove front left wheel and raise vehicle.
- Remove soundproofing panel.
- Remove the front left wheelhouse liner => Body Work; Rep. Gr. 66.

- Release double clamp -1- and separate the exhaust system ▶

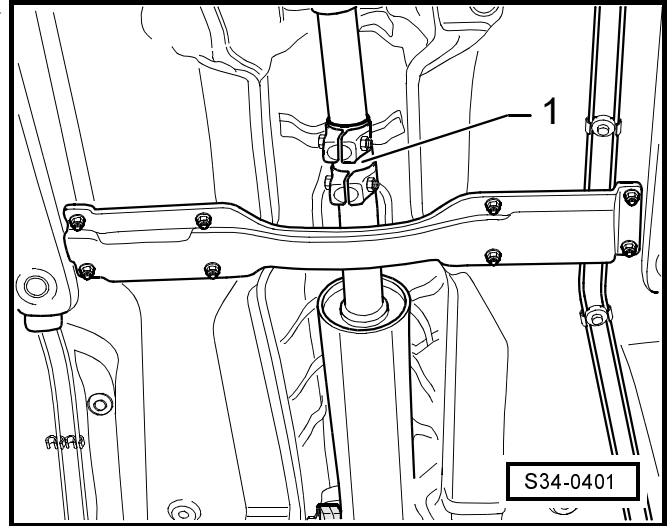

- Remove the earth strap from the front of the gearbox -1-.
- Disconnect plug -2- from the reversing light switch -F4-.
- Unscrew bracket -3- from the gearbox -arrow- and lay aside together with the lines.
- Disconnect the drive shafts from the flange shafts, turn steering wheel to the left.

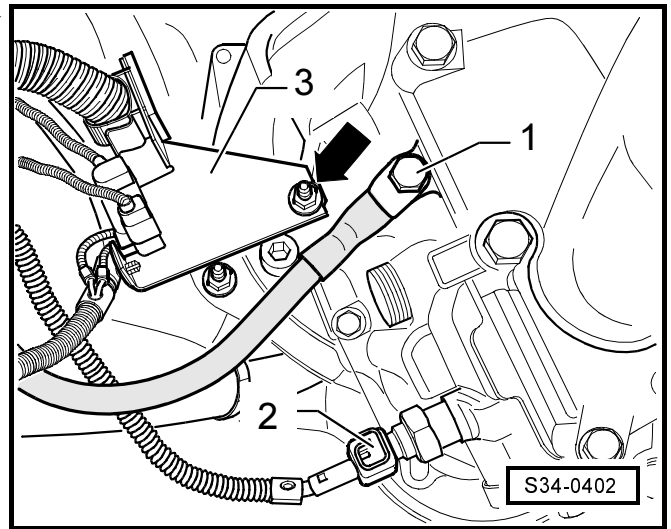

- Mark installation position of bolts -1- for left steering joint, otherwise the steering geometry must be checked.
- Release screws -1-.
- Unbolt coupling rod -2- from the anti-roll bar -arrow-.
- Swivel out the wheel-bearing housing.
- For this step guide the drive shaft into the wheelhouse and secure to the suspension strut with e.g. wire.
- Tie up the right drive shaft as far as possible. Avoid damaging the paintwork on the drive shaft during this operation.

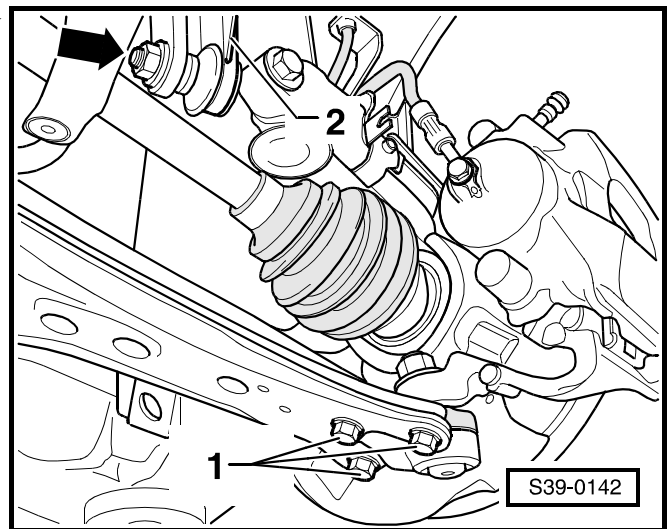

- Unbolt the pendulum support -arrows-.
- Unscrew the stud nut of the engine/gearbox above the right flange shaft.

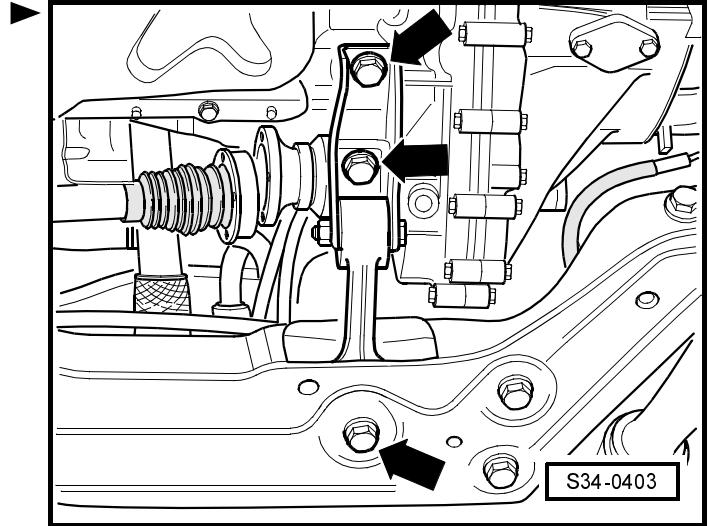

- Install supporting device -MP 9-200-.

i Note

When installing the lifting hooks of the supporting device, pay attention to hose and cable connections in the area of the lifting eyes of the engine to avoid damaging them.

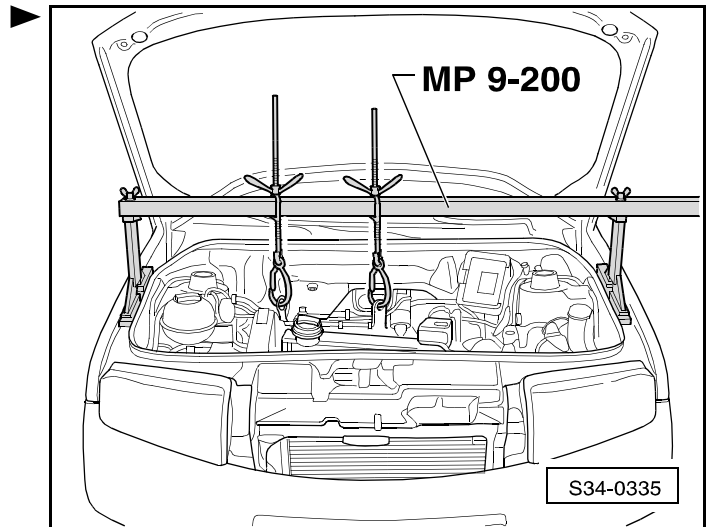

- Take up the weight of the engine/gearbox unit at the spindles.
- Unscrew the fixing screws -arrows- from the gearbox mount.

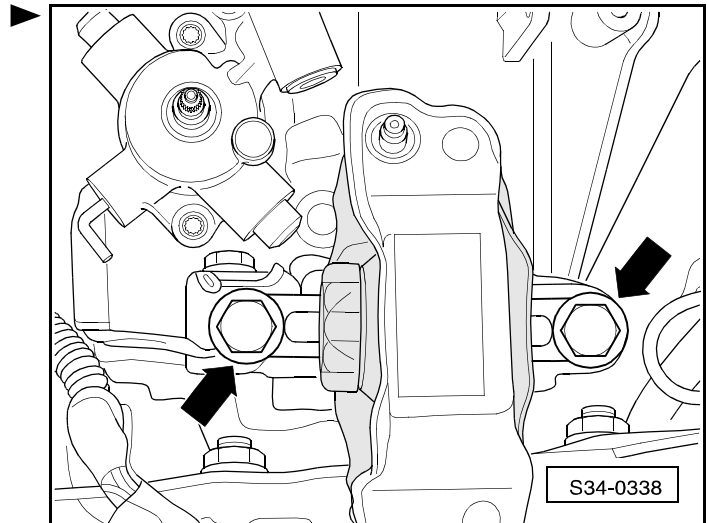

- Detach gearbox mounting bracket -A- from the gearbox. ▶

Remove the fixing screws -arrows- for the gearbox mounting bracket as follows:

- Lower engine/gearbox unit sufficiently at the two spindles until the fixing screws attaching the gearbox mounting bracket -A- are accessible from the left wheelhouse.



Note

When lowering the engine/gearbox unit, make sure the gearbox does not touch the assembly carrier.

- Remove the bottom engine/gearbox connecting screws.
- Insert engine/gearbox mount -3282- into engine/gearbox jack e.g. -V.A.G 1383 A-.

Complete engine/gearbox jack with gearbox mount -3282-, adjusting plate -T30018- for gearbox „002“ and the support elements as follows:

- Position adjusting plate -T30018- on gearbox mount -3282- (adjusting plate fits in only one position).
- Align arms of the gearbox mount to match the holes in the adjusting plate.
- Screw in the mounting elements -A- as shown on adjusting plate. ▶

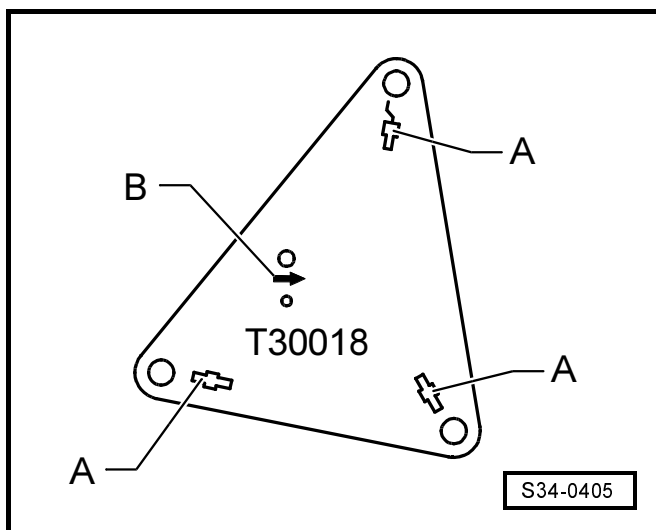
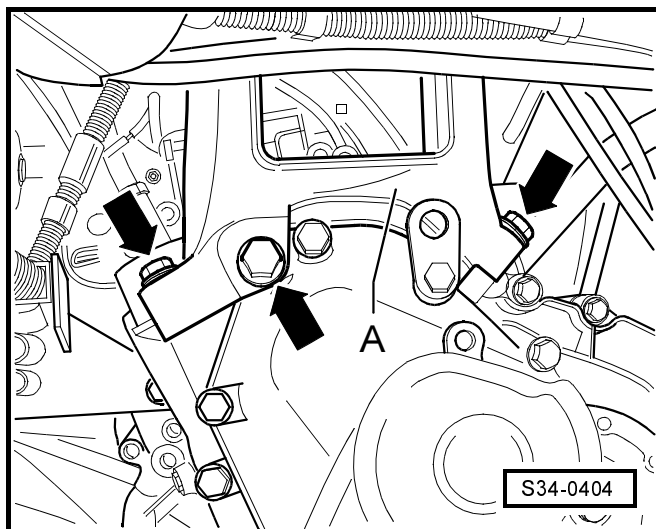

- Position engine/gearbox jack below vehicle, -arrow B- (⇒Fig. S34-0405) on adjusting plate points in the direction of travel/vehicle.
- Screw threaded connector -3114/2- into the gearbox. On threaded side M8 with four washers Ø8 mm -arrow-.
- Align adjusting plate parallel to the gearbox and lock securing mounts at gearbox.
- Unscrew the nut of the engine/gearbox stud.
- Press gearbox off the engine and swivel towards the assembly carrier.
- After this lower gearbox carefully.



Note

Push the engine forwards while lowering the gearbox.

- Change the gearbox position at the spindles of the gearbox mount -3282- when lowering.

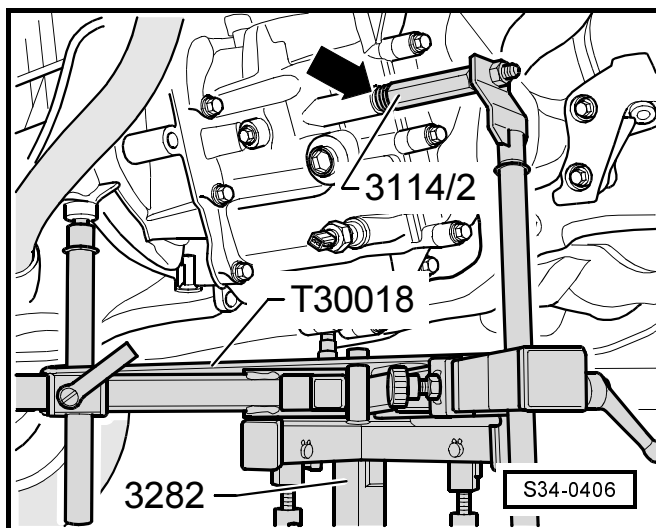

- Screw down gearbox suspension device -MP 3-478- onto clutch housing.

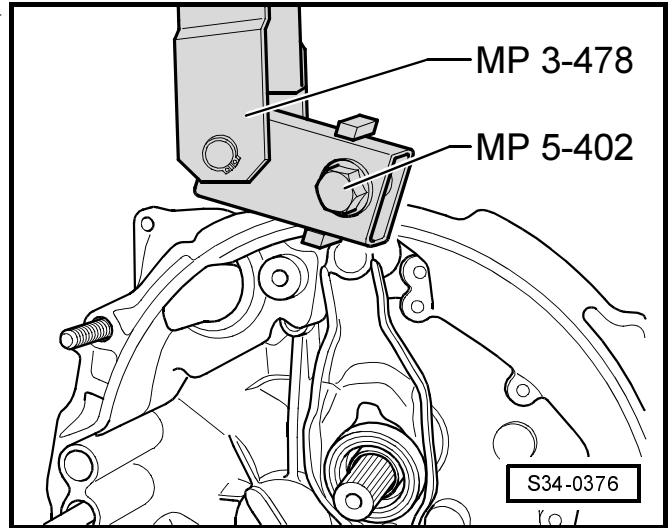

- Adjust supporting arm at slide with locking pin -arrow-.
- Number of visible holes = 8.

- Raise gearbox with workshop crane and gearbox suspension device -MP 3-478-.
- Place down gearbox, e.g. in a transport container.

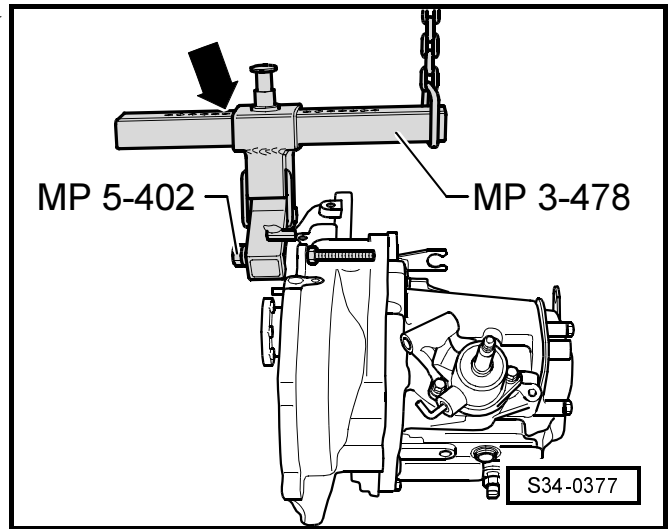

Installing

- Before installing, unscrew plug for gearbox oil inspection and pour in gear oil.

Capacity and specification => Chap. 00-1 .

The installation of the gearbox occurs in reverse order. Pay attention to the stress free assembly bracket in the vehicle; Rep. -Gr. 10 of the relevant engine.

- After installing, check gear oil => Chap. 34-8.

i Note

- ◆ Clean splines of drive shaft and apply a thin film of grease -G 000 100-.
- ◆ If the gearbox is replaced, ensure the intermediate plate between the engine and gearbox is correctly installed.
- ◆ Check whether the dowel sleeves for centering the gearbox are present in the cylinder block; insert if necessary.
- ◆ Installing starter and cables => Electrical System; Rep. Gr. 27.
- ◆ Setting shift mechanism => Chap. 34-1.
- ◆ If the battery earth strap is disconnected and connected, carry out additional operations => Electrical System; Rep. Gr. 27.

Tightening torques

Gearbox on engine.

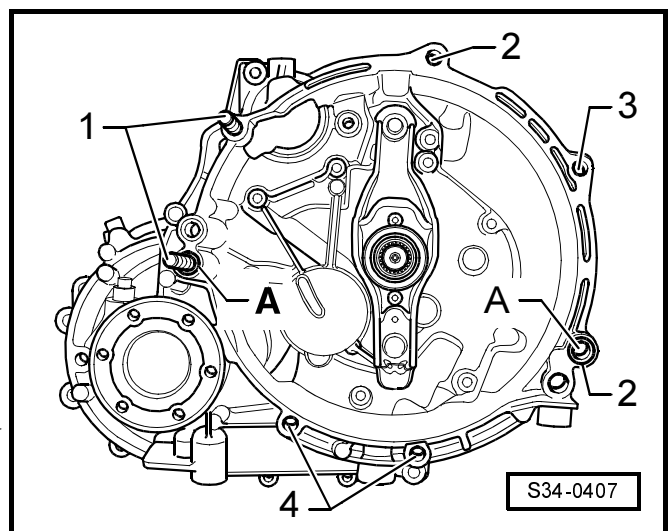

Position	Nut/screw	Qty	Nm
1	Nut M10	2	45
2	Nut M10	2	45
3 ¹⁾	Screw M10	1	45
4	Screw M10	2	45

1) Screw with threaded pin M8

A: Dowel sleeves for centering

Component	Torque
Gearbox mounting bracket to gearbox ¹⁾ M10	40 Nm +90°
Gearbox mounting bracket to gearbox mount ¹⁾ M10	40 Nm +90°
Tighten drive shaft to flange shaft M8 crosswise in 2 steps (I and II) ¹⁾	I - 10 Nm II - 40 Nm
Cable support to gearbox	25 Nm
Gearbox shift lever to gearbox	25 Nm
Steering joint to track control arm ¹⁾ M8	20 Nm +90°
Coupling rod to anti-roll bar	40 Nm
Wheel bolts to wheel hub	120 Nm
Nut for attaching double clamp of exhaust system	40 Nm

1) always replace these bolts

Hinged bracket



Note

Tighten screws -1- in the elongated holes of the support in such a way that the maximum permissible distance is obtained between the gearbox and the assembly carrier.

1 - 30 Nm + 90° (1/4 turn) - replace

2 - 40 Nm + 90° (1/4 turn) - replace

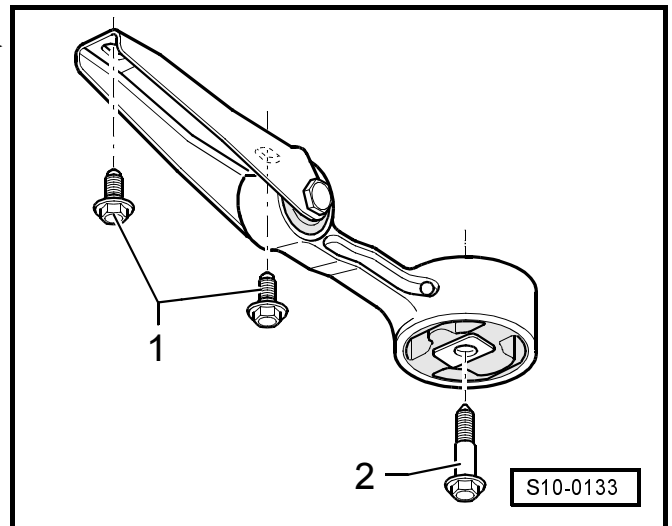

34-8 Inspecting gear oil

Gear oil specification ⇒ 00-1

- Unscrew plug for inspecting gear oil -arrow-.

The oil is at the correct level if the gear is filled up to the lower edge of the oil filler hole.

- Tighten plug -arrow-, 25 Nm.

When re-filling, pay attention to the following points:

- Unscrew plug -arrow-.
- Pour in gear oil up to lower edge of filler hole.
- Screw in plug -arrow-.
- Start engine, engage a gear and allow gearbox to rotate for about 2 minutes.
- Switch off engine, unscrew plug -arrow- and again top up gear oil to lower edge of filler hole.
- Tighten plug -arrow-, 25 Nm.

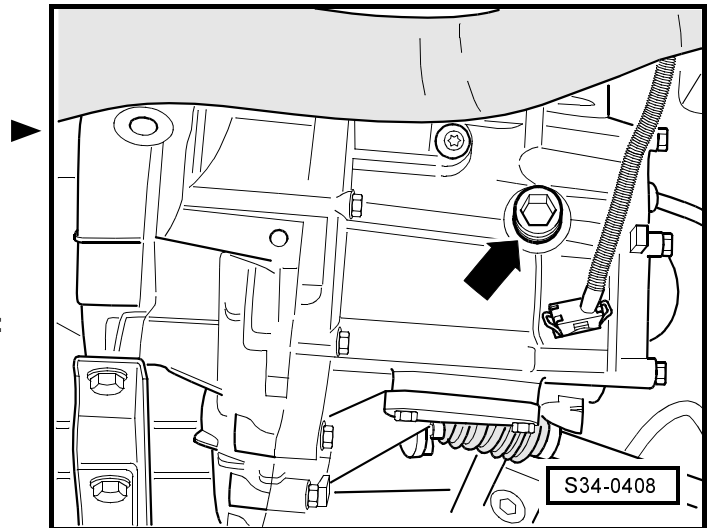

Draining out gear oil

Manual gearboxes up to 09/01.

Oil is drained out through the oil drainage screw
⇒ Chapter 34-10.

Manual gearboxes from 10/01.

These gearboxes do not have an oil drainage screw.

Oil can be sucked out using suction equipment.

Oil can be drained out after removing the following parts:

- ◆ The flange shaft on the side of the clutch housing
⇒ Chapter 39-1

or

- ◆ The manual gearbox cover ⇒ Chapter 34-9

or

- ◆ The gearbox cover ⇒ Chapter 34-9

34-9 Disassembling and assembling the gearbox

Mounting sequence ⇒ **34-9** page 4

- I - Disassembling and assembling gearbox housing cover and 5th gear ⇒ **34-9** page 2
- II - Disassembling and assembling the gearbox housing, drive shaft, output shaft (input shaft), differential and shift mechanism ⇒ **34-9** page 3

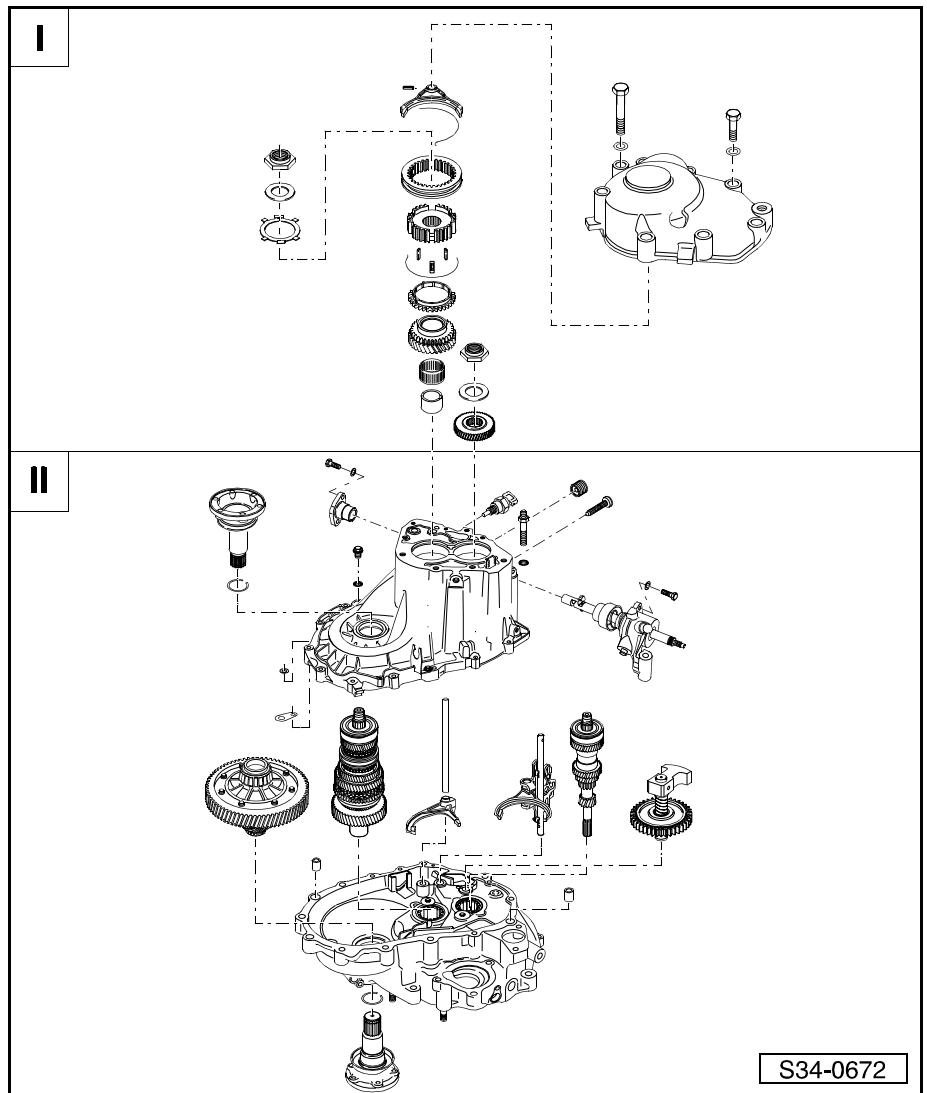

I - Disassembling and assembling gearbox housing cover and 5th gear

Note

If the gearbox housing cover is installed with the gearbox mounted, inspect the oil level and top up with gear oil
⇒ Chap. 34-8.

- 1 - **M8 x 70, 25 Nm**
 - 2 pieces
- 2 - **Washer**
- 3 - **M8 x 45, 25 Nm**
 - 6 pieces
- 4 - **Cover for gearbox housing**
- 5 - **Tensioning sleeve 5 x 22 mm**
 - replace
 - removing and installing
⇒ **34-9** page 4
- 6 - **5th gear shift fork**
 - removing and installing
⇒ **34-9** page 4
- 7 - **Spring**
- 8 - **5th gear sliding sleeve**
 - removing and installing
⇒ **34-9** page 4
- 9 - **5th gear synchronizer body**
- 10 - **Arresters (3 pieces)**
- 11 - **Nut, 85 Nm**
 - for drive shaft
 - always replace
 - when releasing or tightening
observe the installation sequence ⇒ **34-9** page 4
- 12 - **5th gear pinion**
 - fitting position ⇒ **34-9**
page 10
- 13 - **Gearbox housing**
 - repairing ⇒ Chapter 34-10
- 14 - **Bushing for needle bearing**
 - Fitting position: The oil pockets -arrow- point towards the 5th gear synchronizer body.
- 15 - **Needle bearing**
- 16 - **5th gear sliding gear**
- 17 - **5th gear synchronizer ring**
- 18 - **Supporting ring**
 - prevents the arresters from wandering
- 19 - **Disc spring**
 - Fitting position: curved side points to gearbox housing cover
- 20 - **Nut, 60 Nm**
 - for output shaft
 - always replace
 - when releasing or tightening observe the installation sequence ⇒ **34-9** page 4

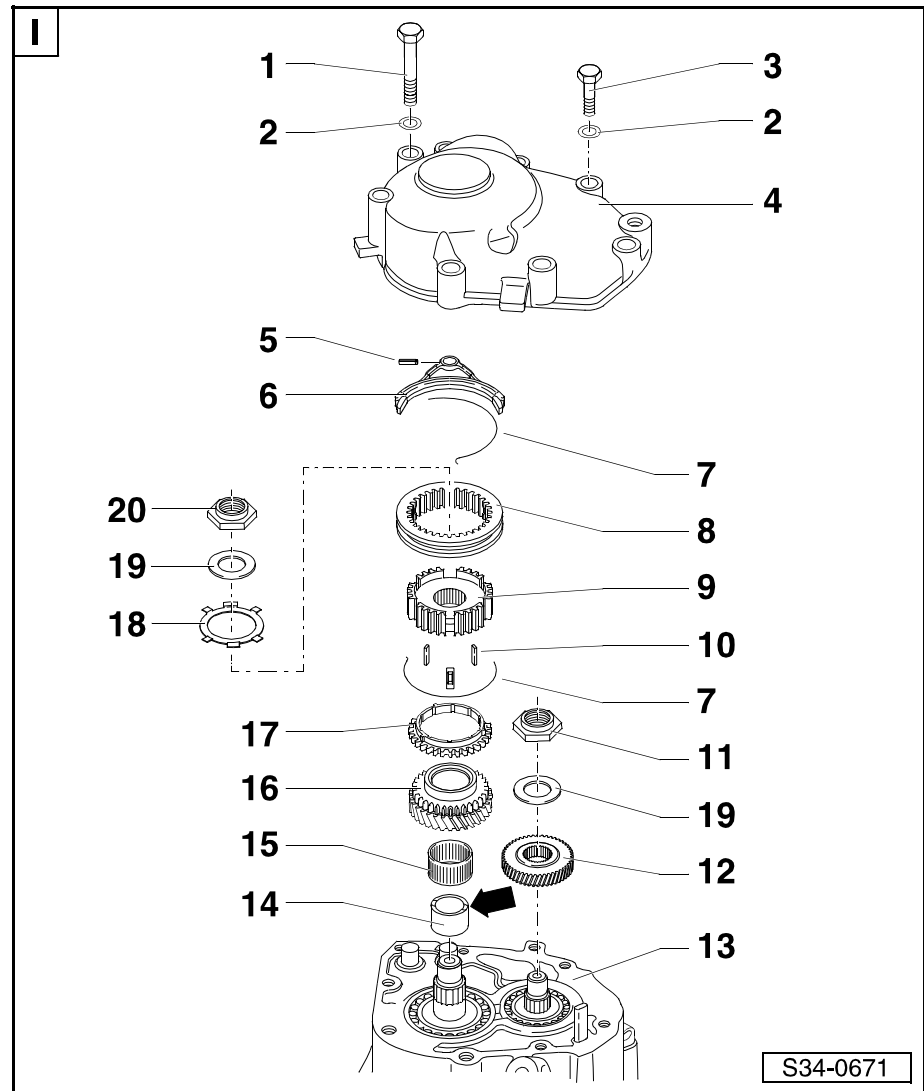

II - Disassembling and assembling the gearbox housing, drive shaft, output shaft (input shaft), differential and shift mechanism

- 1 - Flange shaft**
 - for gearbox up to 06.00
 - removing and installing ⇒ Chapter 39-1
- 2 - Circlip**
 - for gearbox up to 06.00
 - always replace
 - removing and installing ⇒ **34-9** page 10
- 3 - Gasket**
 - for gearboxes up to 09/01
 - replace
- 4 - Oil drain plug, 25 Nm**
 - for gearboxes up to 09/01
 - without magnet
- 5 - 25 Nm**
- 6 - Washer**
- 7 - Cap**
- 8 - Gearbox housing**
 - repairing ⇒ Chapter 34-10
- 9 - Switch for reversing lights -F4-, 15 Nm**
 - before installing apply sealant -THREE BOND 1324 -
 - pay attention to different versions
- 10 - Double screw, 25 Nm**
- 11 - Oil filler plug, 25 Nm**
- 12 - 30 Nm**
 - for reverse shaft support
- 13 - M8 x 45, 25 Nm**
- 14 - Suspension lug**
- 15 - Shift mechanism**
 - disassembling and assembling ⇒ Chapter 34-12
- 16 - Output shaft**
 - disassembling and assembling ⇒ Chapter 35-2
- 17 - Magnet**
 - to collect dirt
- 18 - Gear shift rod for gears 1 through 4**
- 19 - 1st/2nd gear shift fork**
- 20 - 5th gear shift rod with 3rd/4th gear shift fork**
 - with gear shift rail for 1st through 4th gear and reverse gear
 - disassembling and assembling ⇒ Chapter 34-13
- 21 - Drive shaft**
 - disassembling and assembling ⇒ Chapter 35-1
- 22 - Reverse shaft support**
 - disassembling and assembling ⇒ Chapter 35-3
- 23 - Fit bushing**
- 24 - Clutch housing**
 - repairing ⇒ Chapter 34-11

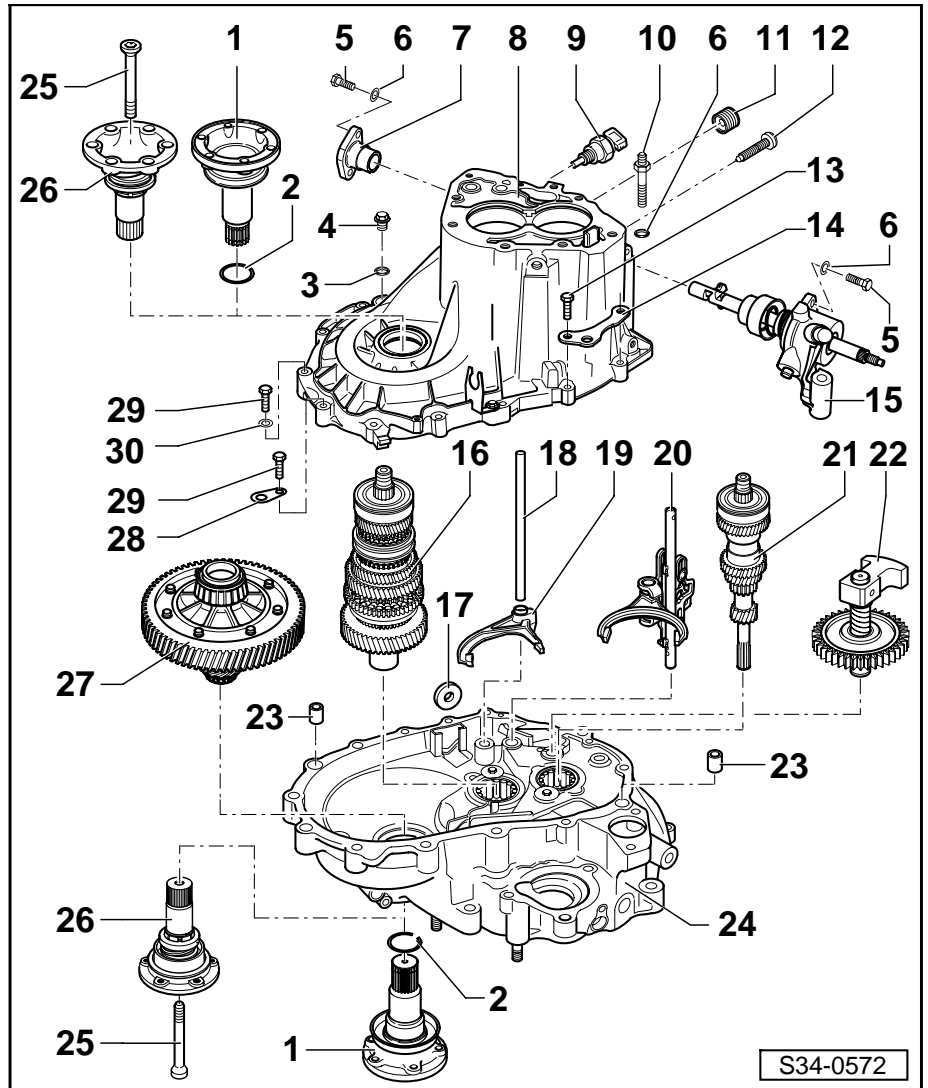

25 - Conical screw, 25 Nm

- for gearbox after 06.00
- removing and installing ⇒ Chapter 39-1

26 - Flange shaft with pressure spring

- for gearbox after 06.00

27 - Differential

- disassembling and assembling ⇒ Chapter 39-2

28 - Suspension lug**29 - M8 x 50, 25 Nm****Mounting sequence**

Removing and installing the gearbox housing cover, gearbox housing, drive shaft, output shaft (input shaft), differential and shift mechanism

Special tools, test and measuring equipment and auxiliary items required

- ◆ Driver -MP 1-304-
- ◆ Multi-purpose tool -MP 3-419-
- ◆ Adapter -MP 3-419/40-
- ◆ Gearbox mount -MP 3-501-
- ◆ Extractor for tensioning sleeve -MP 3-509-
- ◆ Bolt chisel -MP 3-533-
- ◆ Pliers for securing the drive shaft nut -MP 3-605-
- ◆ Assembly stand -MP 9-101-
- ◆ Sealant -THREE BOND 1104-
- ◆ Sealant -THREE BOND 1324-

Disassembling

- Drain out the gear oil ⇒ Chapter 34-8 .
- Secure gearbox to the gearbox mount -arrows-.
- Removing the clutch release lever, clutch release bearing and guide bushing ⇒ Chap. 30-2.

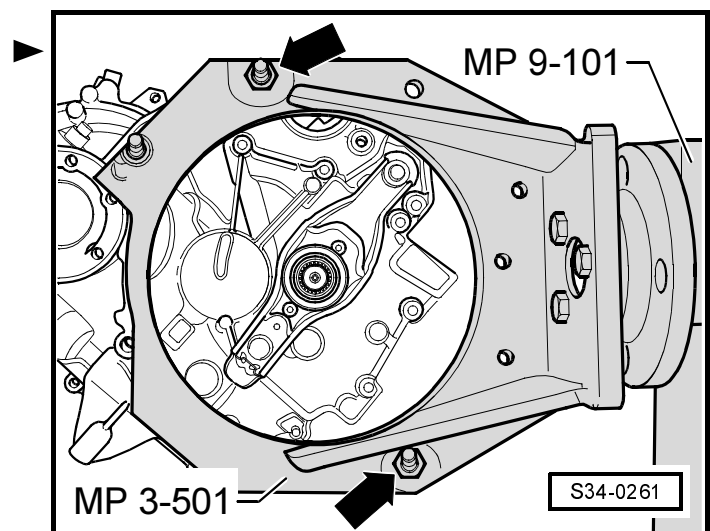

- Unscrew the cover -arrow- for the gearbox housing. ▶

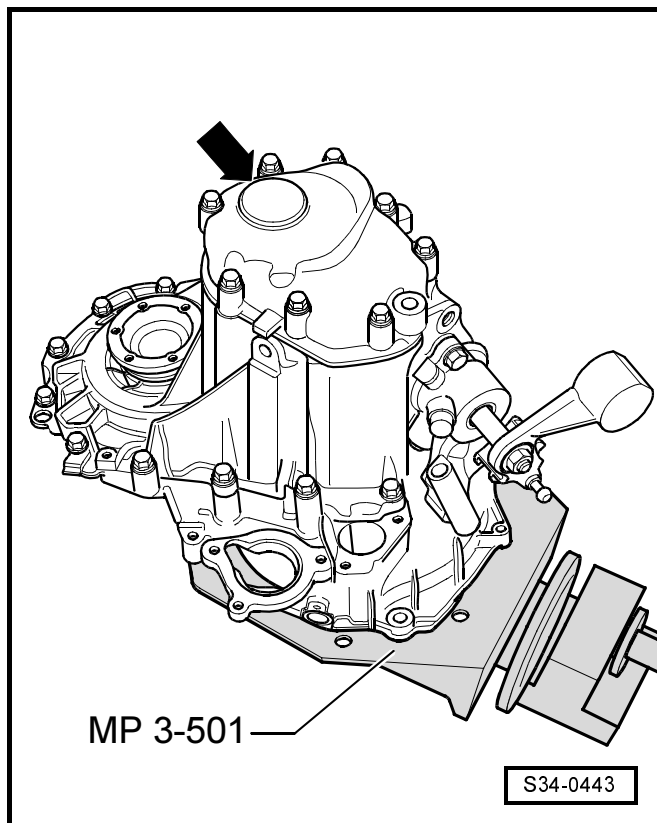

- Extract the tensioning sleeve for the 5th gear shift fork with tensioning sleeve extractor -MP 3-509-. ▶

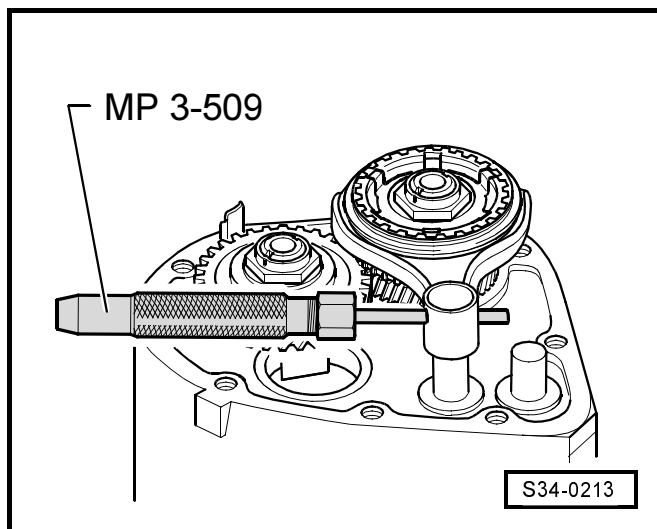

- Unlock the nuts for the input and output shaft with bolt chisel -MP 3-533-. ▶

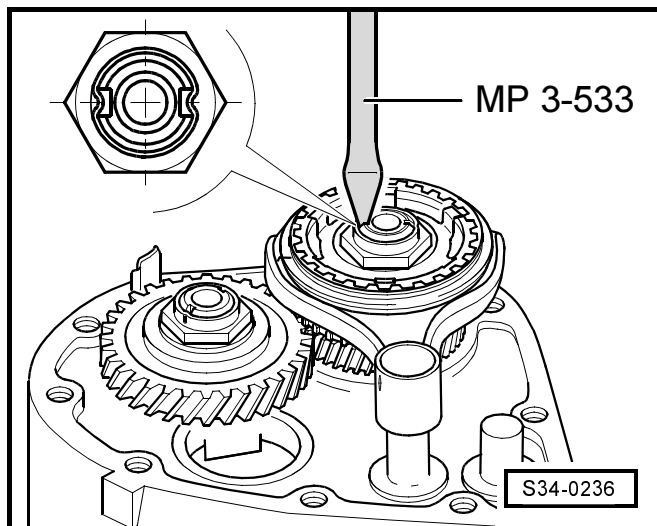

- Unscrew the nuts -A- for synchronizer body and 5th gear pinion. To this end engage the 5th gear -arrow 1- and 1st gear -arrows 2 and 3-.
- The input and output shafts are blocked after introducing the two gears, the synchronizer body and pinion cannot rotate. Now it is possible to release the two nuts.
- 5. Slide the 5th gear over the sliding sleeve.
- Put the gearshift shaft into Neutral.
- Remove the 5th gear shift fork, sliding sleeve and synchronizer body with 5th gear pinion simultaneously.
- Remove the 5th gear pinion

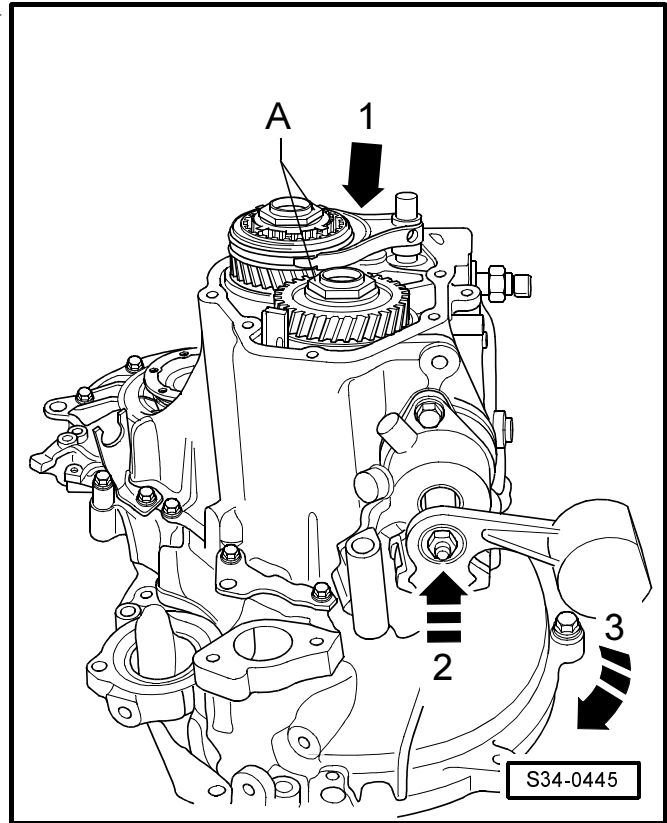

For gearbox after 06.00

- Secure the flange shaft against turning and release the screw -arrow-.

The figure shows how to remove the screws from the left flange shaft. Proceed in the same way to remove the screws from the right flange shaft.

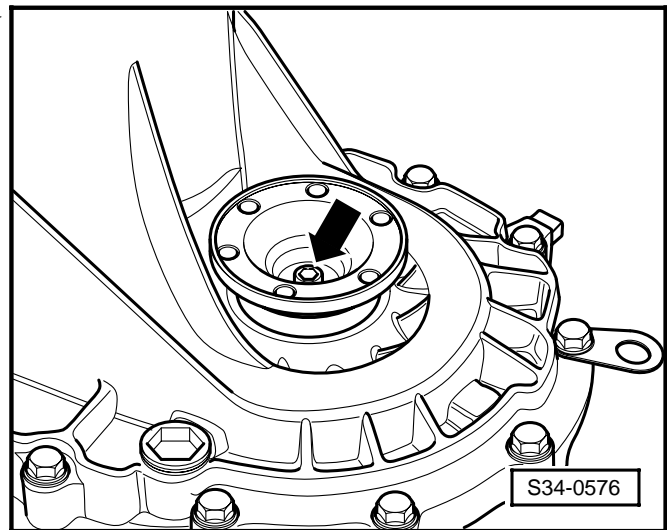

For all gearboxes

- Remove the left and right flange shafts
- Remove the switch -A- for reversing lights -F4-.
- Remove the screws -arrows- for the cover -B-.

The figure shows how to remove the left flange shaft. Proceed in the same way to remove the right flange shaft.

