

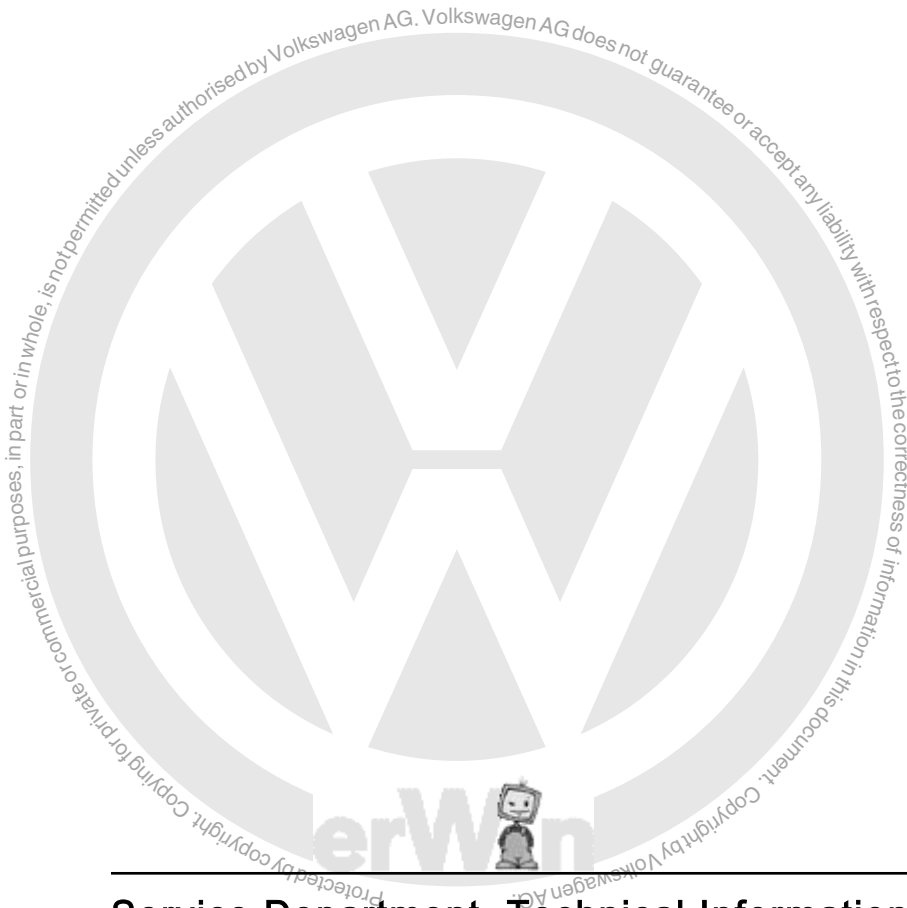

Workshop Manual Golf 2004 ➤

General body repairs, exterior

Edition 04.2008





List of Workshop Manual Repair Groups

Repair Group

50 - Body - front

55 - Bonnet, rear lid

57 - Front doors, door components, central locking

58 - Rear doors, door components

60 - Sunroof

63 - Bumpers

64 - Glazing

66 - Exterior equipment



Technical information should always be available to the foremen and mechanics, because their careful and constant adherence to the instructions is essential to ensure vehicle road-worthiness and safety. In addition, the normal basic safety precautions for working on motor vehicles must, as a matter of course, be observed.

All rights reserved.
No reproduction without prior agreement from publisher.



Contents

50 - Body - front	1
1 Lock carrier	1
1.1 Tools	1
1.2 Assembly overview - lock carrier, service position	2
1.3 Service position	3
1.4 Removing and installing lock carrier with add-on parts	4
2 Wing	7
2.1 Tools	7
2.2 Assembly overview - front wing	8
2.3 Removing and installing wing	8
2.4 Removing and installing wing strut	10
3 Noise insulation	12
3.1 Tools	12
3.2 Assembly overview - noise insulation	13
4 Underbody cladding	14
4.1 Tools	14
4.2 Assembly overview - underbody cladding	15
5 Plenum chamber bulkhead	16
5.1 Tools	16
5.2 Assembly overview - plenum chamber bulkhead	16
55 - Bonnet, rear lid	17
1 Bonnet	17
1.1 Tools	17
1.2 Assembly overview - bonnet	18
1.3 Removing and installing bonnet	19
1.4 Removing gas strut	20
1.5 Releasing gas from gas strut	20
1.6 Removing and installing flap hinge	20
1.7 Removing and installing insulation	22
1.8 Assembly overview - bonnet latch and release components	24
1.9 Removing and installing bonnet lock	25
1.10 Separating Bowden cable	26
1.11 Adjusting bonnet	26
1.12 Removing and installing release lever	28
2 Rear lid	29
2.1 Tools	29
2.2 Assembly overview - rear lid	29
2.3 Removing and installing rear lid	30
2.4 Removing gas strut	31
2.5 Releasing gas from gas strut	31
2.6 Removing and installing rear lid hinges	31
2.7 Removing and installing striker pin	34
2.8 Adjusting lid	34
2.9 Assembly overview - rear lid latch and release components	37
2.10 Removing and installing release element	37
2.11 Removing and installing lid lock	39
2.12 Rear lid seal	39
2.13 Removing and installing rear lid seal	40
3 Tank flap unit	41
3.1 Tools	41
3.2 Assembly overview - tank flap unit	41



57 - Front doors, door components, central locking	45
1 Front door	45
1.1 Tools	45
1.2 Materials	46
1.3 Assembly overview - door assembly	46
1.4 Assembly overview - door hinges	48
1.5 Removing and installing door	50
1.6 Adjusting door	52
1.7 Removing and installing door outer panel	55
1.8 Installing new outer panel for door	58
1.9 Removing and installing retaining rail on door outer panel	62
1.10 Installation instructions for bonding in new door outer panel	63
1.11 Minimum curing period	64
1.12 Cleaning off excess adhesive sealing material	64
1.13 Assembly overview - door inner part	65
1.14 Assembly overview - door handle and door lock	66
1.15 Removing and installing housing	67
1.16 Removing and installing door handle	68
1.17 Removing and installing mounting plate	70
1.18 Removing and installing door lock	72
1.19 Assembly overview - side impact protection	74
1.20 Door inner seal	74
1.21 Removing and installing door inner seal	75
1.22 Removing and installing door outer seal	77
2 Central locking	80
2.1 Location overview - central locking components	80
2.2 Adapting keys with remote control	81
2.3 Assembly overview - battery for folding key with remote control	82
2.4 Removing and installing battery for folding key with remote control	83
58 - Rear doors, door components	85
1 Rear door	85
1.1 Tools	85
1.2 Materials	86
1.3 Assembly overview - door assembly	86
1.4 Assembly overview - door hinges	88
1.5 Removing and installing door	89
1.6 Adjusting door	91
1.7 Removing and installing door outer panel	94
1.8 Installing new outer panel for door	97
1.9 Removing and installing retaining rail on door outer panel	101
1.10 Installation instructions for bonding in new door outer panel	102
1.11 Minimum curing period	103
1.12 Cleaning off excess adhesive sealing material	103
1.13 Assembly overview - door inner part	104
1.14 Assembly overview - door handle and door lock	105
1.15 Removing and installing housing	106
1.16 Removing and installing door handle	106
1.17 Removing bearing bracket	108
1.18 Removing and installing door lock	110
1.19 Assembly overview - side impact protection	111
1.20 Door inner seals	112
1.21 Removing and installing door inner seal	113
1.22 Removing and installing door outer seal	114



60 - Sunroof	118
1 Sliding/tilting sunroof with glass panel (Meritor)	118
1.1 Tools	118
1.2 Function	119
1.3 Assembly overview - sliding/tilting sunroof with glass panel	120
1.4 Removing and installing bellows	122
1.5 Removing glass panel of sliding/tilting sunroof	123
1.6 Installing glass panel of sliding/tilting sunroof	124
1.7 Adjusting height of glass panel of sliding/tilting sunroof	124
1.8 Adjusting panel seal	125
1.9 Renewing panel seal	126
1.10 Removing and installing wind deflector	126
1.11 Removing and installing sliding headliner	127
1.12 Removing and installing sliding/tilting sunroof glass panel drive	128
1.13 Adjusting drive for sliding/tilting sunroof glass panel (0 position)	129
1.14 Removing and installing sliding/tilting sunroof glass panel automatic preselection switch	130
1.15 Checking parallel running	130
1.16 Adjusting parallel running	130
1.17 Assembly overview - carrier unit	131
1.18 Removing and installing carrier unit	132
1.19 Operating without electrics	134
1.20 Removing and installing guide plate	134
1.21 Removing and installing sliding gate	135
1.22 Cleaning water drain hoses	136
63 - Bumpers	139
1 Front bumper	139
1.1 Tools	139
1.2 Repairing bumper cover	139
1.3 Assembly overview - bumper cover	140
1.4 Removing and installing front bumper cover	140
1.5 Front bumper attachments	142
1.6 Front bumper substructure	143
1.7 Assembly overview - bumper carrier	144
1.8 Assembly overview - number plate carrier	145
2 Front bumper for GTI, GTI special models, GT, R32	146
2.1 Tools	146
2.2 Repairing bumper cover	146
2.3 Assembly overview - bumper cover for GTI, GT	146
2.4 Removing and installing front bumper cover for GT, GTI	147
2.5 Front bumper attachments for GT, GTI	149
2.6 Assembly overview - bumper cover for R32	151
2.7 Removing and installing front bumper cover for R32	151
2.8 Front bumper attachments for R32	153
2.9 Assembly overview - front bumper cover for GTI special models	154
2.10 Removing and installing front bumper cover for GTI special models	154
2.11 Front bumper attachments for GTI special models	156
2.12 Front bumper substructure	157
2.13 Assembly overview - bumper carrier	158
3 Rear bumper	159
3.1 Tools	159
3.2 Repairing bumper cover	159
3.3 Assembly overview - bumper cover	160
3.4 Removing and installing bumper cover	160



3.5	Rear bumper attachments	162
3.6	Rear bumper substructure	163
3.7	Assembly overview - bumper carrier	164
3.8	Assembly overview - towing bracket	164
4	Rear bumper for R32 and GTI special models	166
4.1	Tools	166
4.2	Repairing bumper cover	166
4.3	Assembly overview - bumper cover for R32	167
4.4	Removing and installing bumper cover for R32	167
4.5	Rear bumper attachments for R32	169
4.6	Assembly overview - rear bumper cover for GTI special models	170
4.7	Removing and installing rear bumper cover for GTI special models	170
4.8	Rear bumper attachments for GTI special models	172
4.9	Rear bumper substructure	173
4.10	Assembly overview - bumper carrier	174
64	Glazing	175
1	Flush bonded windows	175
1.1	Tools	175
1.2	Materials	177
1.3	Repairing windscreen	177
1.4	Assembly overview - windscreen	178
1.5	Assembly overview - plenum chamber cover	179
1.6	Removing windscreen	182
1.7	Installing windscreen	182
1.8	Assembly overview - rear window	183
1.9	Removing undamaged rear window	183
1.10	Removing broken rear window	184
1.11	Installing rear window	185
1.12	Assembly overview - rear side window	186
1.13	Removing undamaged rear side window	186
1.14	Removing damaged rear side window	187
1.15	Installing rear side window	187
1.16	Preparing old undamaged window for glazing	188
1.17	Preparing new window without precoating for glazing	188
1.18	Preparing new window with precoating for glazing	189
1.19	Preparing body flange for glazing	190
1.20	Installation instructions	191
1.21	Minimum curing period	191
1.22	Touching up paint damage	192
1.23	Cleaning off excess adhesive sealing material	192
2	Front door windows	193
2.1	Tools	193
2.2	Assembly overview - front door window	194
2.3	Removing and installing door window	195
2.4	Adjusting door window	197
2.5	Assembly overview - window regulator motor	198
2.6	Removing and installing window regulator motor	199
2.7	Assembly overview - window guide	201
2.8	Removing and installing window guide	201
2.9	Assembly overview - window regulator	203
2.10	Removing and installing window regulator	203
3	Rear door windows	205
3.1	Tools	205
3.2	Assembly overview - rear door window	206



3.3	Removing and installing door window	206
3.4	Assembly overview - fixed door window with window guide	209
3.5	Removing and installing fixed door window with window guide	209
3.6	Assembly overview - window regulator motor	212
3.7	Removing and installing window regulator motor	212
3.8	Assembly overview - window regulator	215
3.9	Removing and installing window regulator	215
66	Exterior equipment	217
1	Wheel housing liner	217
1.1	Tools	217
1.2	Assembly overview - front wheel housing liner	218
1.3	Removing and installing front wheel housing liner	218
1.4	Assembly overview - rear wheel housing liner	220
1.5	Removing and installing rear wheel housing liner	220
2	Exterior mirror	222
2.1	Tools	222
2.2	Assembly overview - exterior mirror	223
2.3	Removing and installing mirror glass	223
2.4	Removing and installing mirror housing	224
2.5	Removing and installing trim	226
2.6	Removing and installing side turn signals	226
2.7	Removing and installing exterior mirror	227
3	Radiator grille	229
3.1	Tools	229
3.2	Assembly overview - radiator grille	229
3.3	Removing and installing radiator grille	230
3.4	Assembly overview - radiator grille for GTI, GTI special models and GT	231
3.5	Removing and installing radiator grille for GT, GTI special models and GT	233
3.6	Radiator grille for GTI, GTI special models, GT and R32 - number plate carrier	235
3.7	Assembly overview - radiator grille for R32	236
3.8	Removing and installing radiator grille for R32	237
3.9	R32 radiator grille - company emblem	239
4	Mouldings and trims	240
4.1	Tools	240
4.2	Assembly overview - water deflector	241
4.3	Removing and installing water deflector	242
4.4	Assembly overview - protective side strips	244
4.5	Renewing side protective mouldings	245
4.6	Removing and installing stone-chip protection trim	246
4.7	Assembly overview - side member extension for GTI, GTI special models and R32	250
4.8	Removing and installing side member extension for GTI, GTI special models and R32	251
4.9	Retaining strip for side member extension	253
5	Roof edge spoiler	257
5.1	Tools	257
5.2	Materials	257
5.3	Assembly overview - roof spoiler for GTI, GTI special models and R32	258
5.4	Removing and installing roof spoiler for GTI, GTI special models and R32	259
5.5	Retaining strip	262
5.6	Preparing body kit component for bonding	263
5.7	Installation instructions	264
5.8	Minimum curing period	264
5.9	Touching up paint damage	264
5.10	Cleaning off excess adhesive sealing material	265
6	Protective backing	266



6.1	Attachment notes for protective backing	266
6.2	Renewing scuff protection film	267
7	Lettering	268
7.1	Tools	268
7.2	Installation instructions for lettering and emblems	268
7.3	Rear lettering dimensions	269
7.4	Rear lettering dimensions for GTI and R32	270
7.5	Rear lettering dimensions - USA	272
7.6	Side lettering dimensions - Individual	273
8	Vermin repellent system	276
8.1	Assembly overview - vermin repellent system	276





50 – Body - front

1 Lock carrier

1.1 Tools

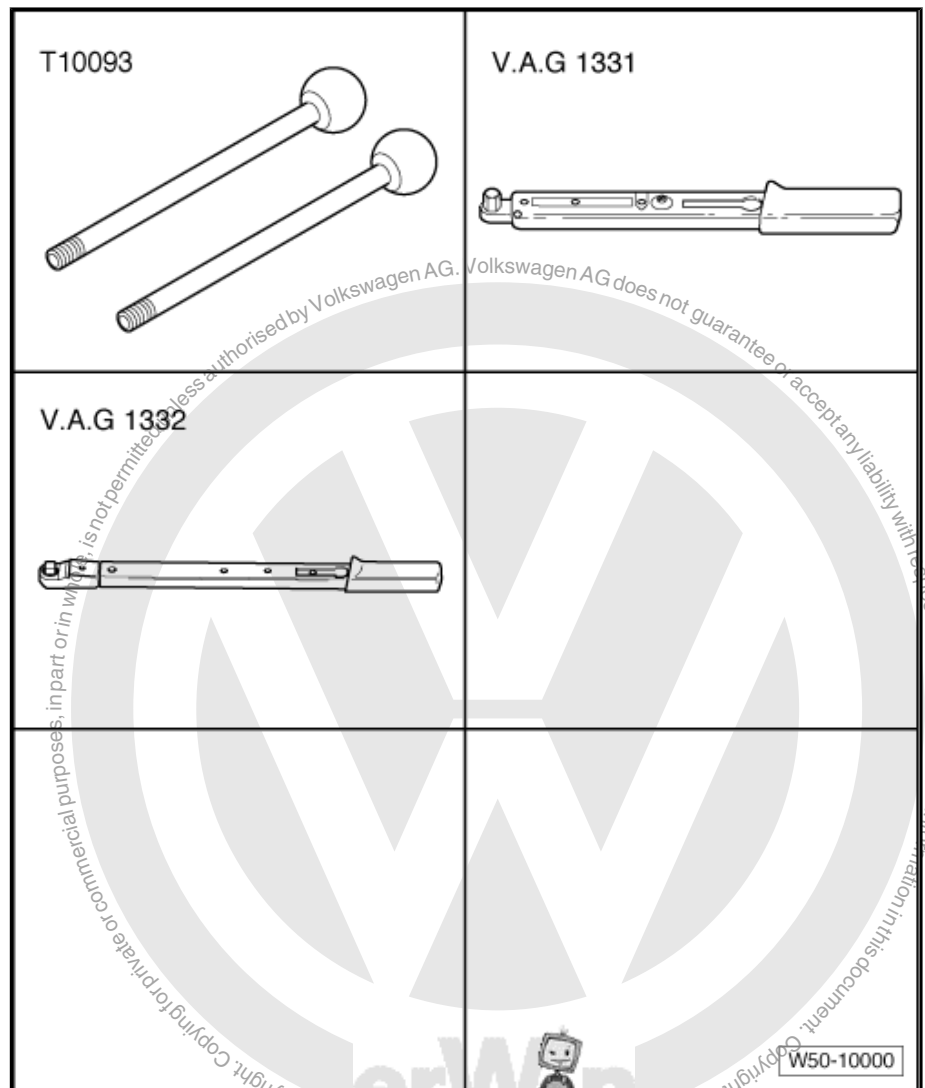

1.1.1 Required special tools, workshop equipment, test and measuring devices and auxiliary items

- ◆ Guide pins -T 10093-
- ◆ Torque wrench 5...50 Nm -V.A.G 1331-
- ◆ Torque wrench 40...200 Nm -V.A.G 1332-



1.2 Assembly overview - lock carrier, service position

1 - Lock carrier with add-on parts

- Removing and installing
⇒ [page 4](#)
- Service position
⇒ [page 3](#)

2 - Bolt

- Qty. 4
- 8 Nm

3 - Bolt

- Qty. 8
- 60 Nm

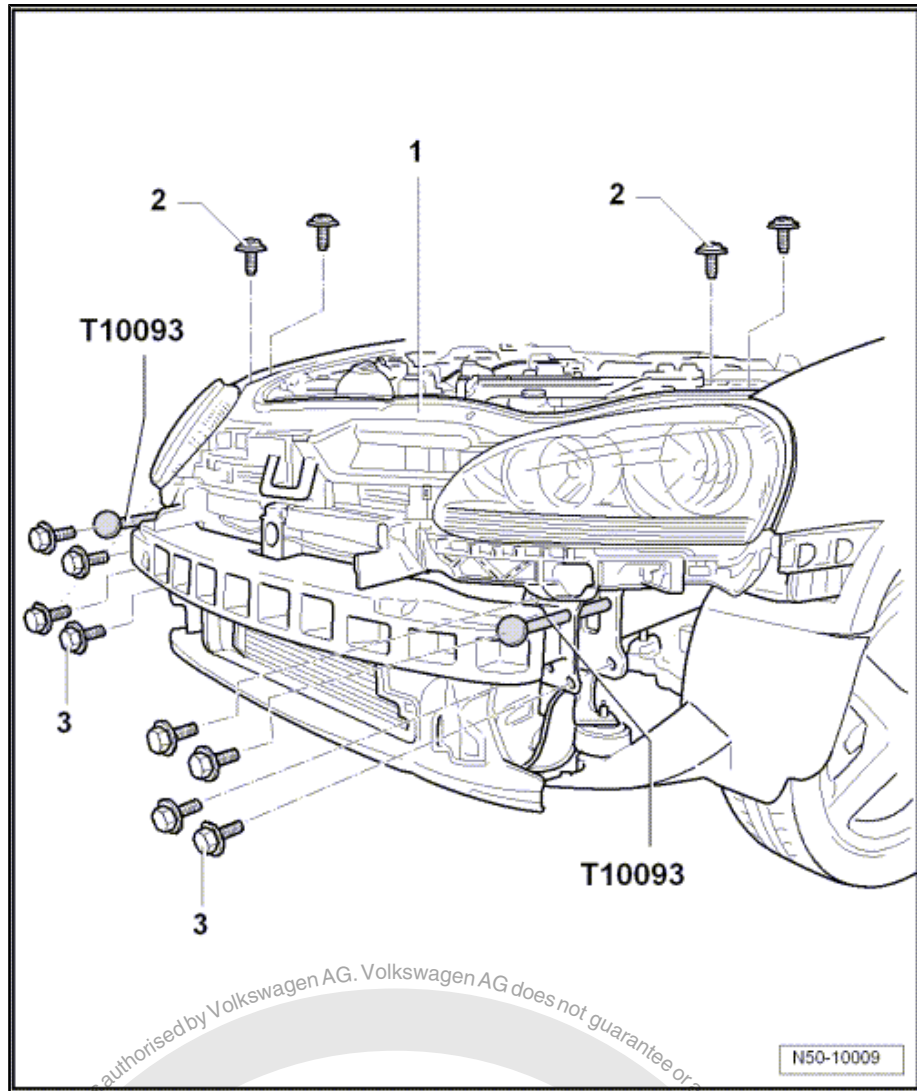



1.3 Service position

1.3.1 Moving to service position

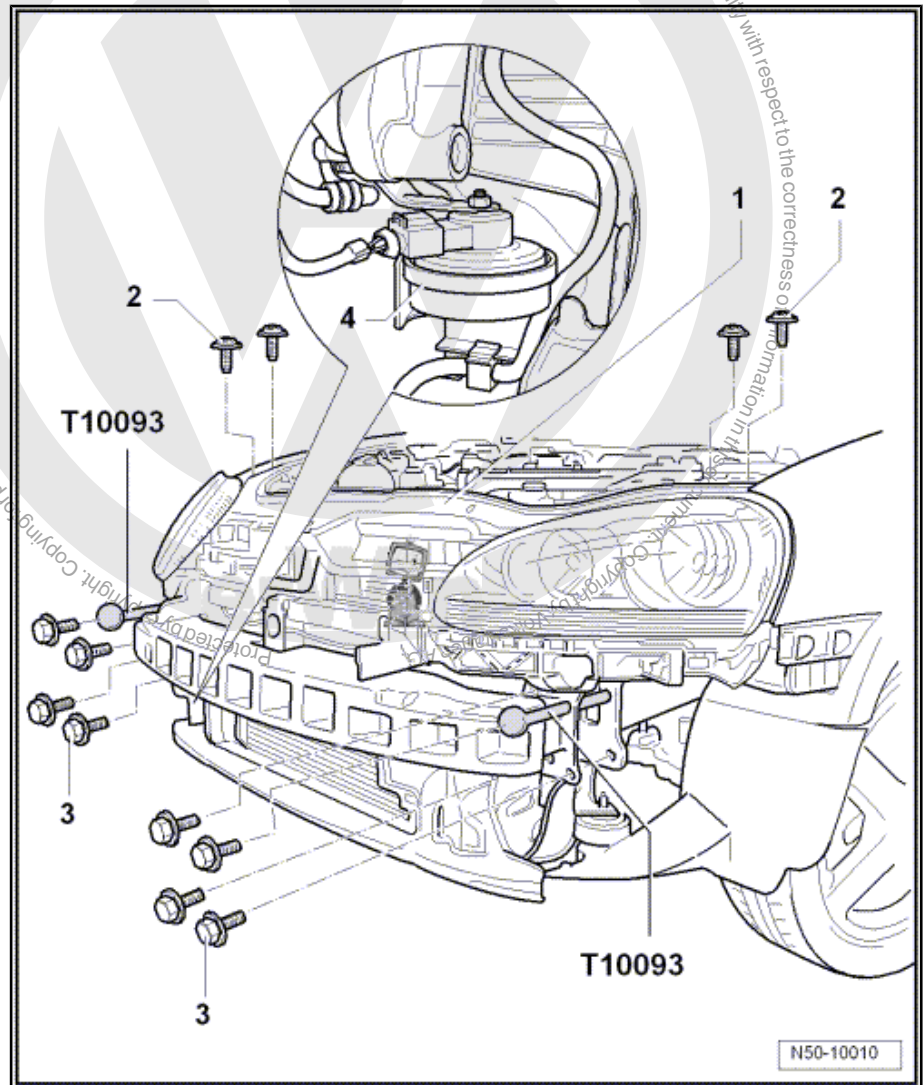

- Remove front bumper ⇒ [page 140](#) , GTI ⇒ [page 147](#) , R32 ⇒ [page 151](#) .
- Unhook Bowden cable at coupling ⇒ [page 26](#) .
- If vehicle has charge air cooler, disconnect pressure hoses ⇒ [page 4](#)
- Unscrew horn -4- with bracket on right side of longitudinal member.⇒ Electrical system; Rep. Gr. 96 ; Interior lights, lamps, switches; Removing and installing horn .
- Remove bolts -3- from left and right longitudinal members.
- Attach special tool guide pins -T 10093- to left and right longitudinal members.
- Remove bolts -2- on left and right from upper part of lock carrier -1-.
- The lock carrier -1- can be pulled forwards about 10 cm on the special tool guide pins -T 10093- .



1.3.2 Moving from service position

Install in reverse order of removal.

- Align lock carrier to longitudinal members and between wings
⇒ Body Repairs; Rep. Gr. 00 ; Technical data; Body gap dimensions .



Note

- ◆ *Ensure that the charge air cooler pressure hoses are properly engaged again.*
- ◆ *Hoses and lines must not be pinched.*

1.3.3 Releasing pressure hoses

- Release push-on coupling -1- and pull pressure hose -2- in -direction of arrow- out of coupling.
- During installation of pressure hoses, ensure that push-on coupling engages audibly.

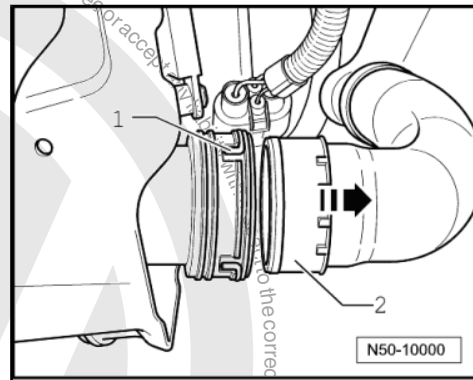

1.4 Removing and installing lock carrier with add-on parts

1.4.1 Removing



Note

- ◆ *Because the lock carrier is a safety-relevant component, it must not be repaired.*
- ◆ *If damaged, the lock carrier must be renewed.*

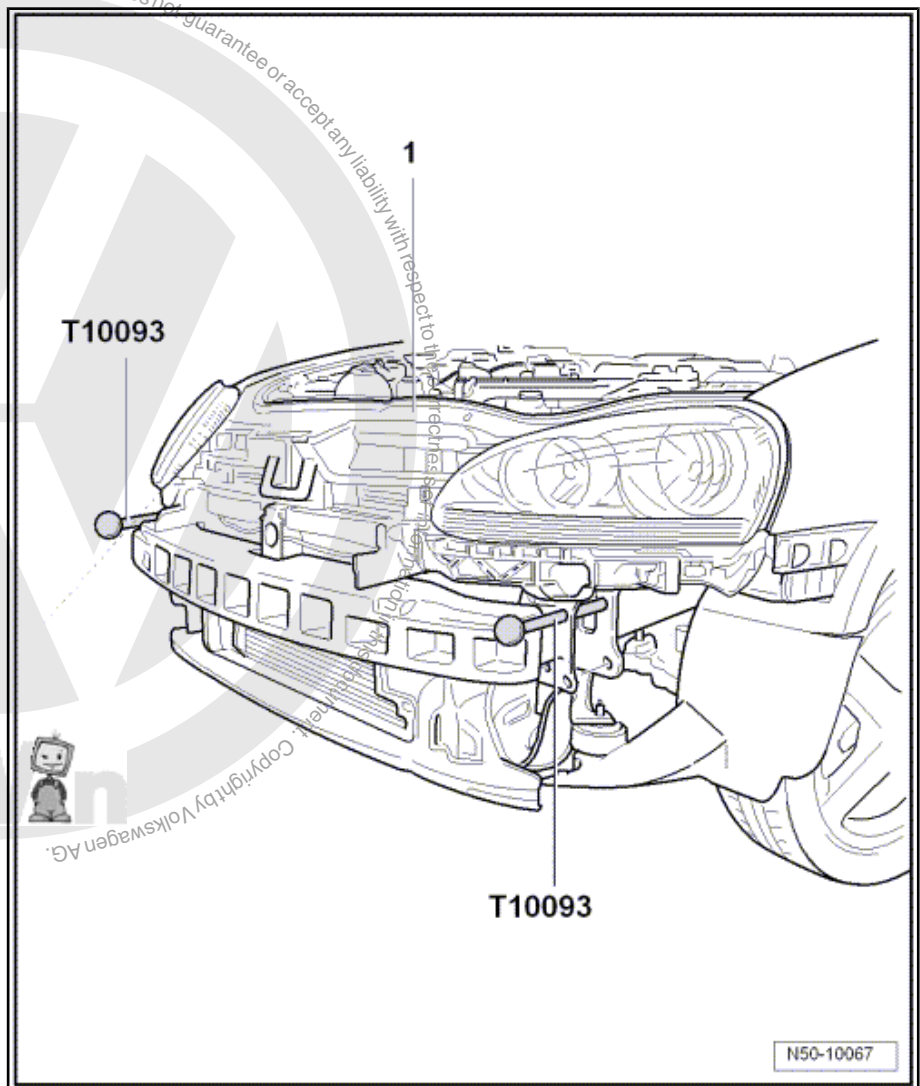

- Set lock carrier with add-on parts -1- to service position
⇒ [page 3](#)
- Disconnect all electrical connectors.
- Drain coolant and disconnect coolant lines ⇒ Engine cooling system; Rep. Gr. 19 ; Parts of cooling system; Draining and filling coolant .
- Disconnect wiring for condenser ⇒ Heating and air conditioning system; Rep. Gr. 87 ; Air conditioning system; Removing and installing condenser .
- Together with a second mechanic, unscrew guide pins -T 10093- from left and right longitudinal member and lift lock carrier out.

**WARNING**

Do not start the engine if the air conditioning system and/or the coolant system lines are disconnected.



Note

- ◆ *Do not hang condenser and hydraulic oil cooler from lines.*
- ◆ *Do not kink condenser and hydraulic lines.*

1.4.2 Installing

Install in reverse order of removal.

- During assembly, ensure that all connectors and hose connections are properly installed.
- Align lock carrier to longitudinal members and between wings
⇒ Body Repairs; Rep. Gr. 00 ; Technical data; Body gap dimensions .





2 Wing

2.1 Tools

Special tools and workshop equipment required

- ◆ Torque wrench 2...10 Nm -V.A.G 1783-

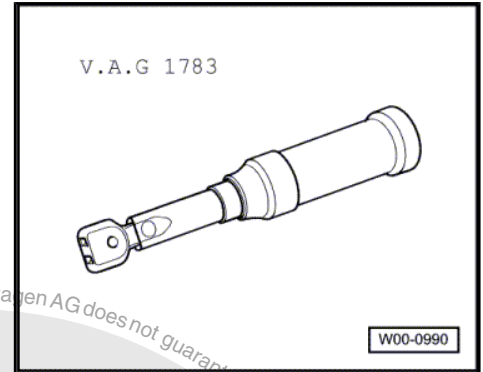

- ◆ Hot air blower -V.A.G 1416-

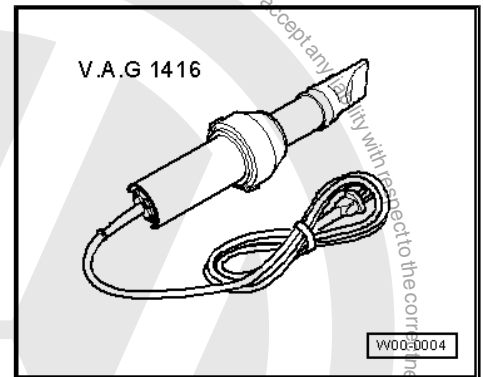



2.2 Assembly overview - front wing



Note

Only the left side is shown. The right side is similar.

1 - Wing

- ❑ Removing and installing
⇒ [page 8](#)

2 - Bolt

- ❑ Qty. 1, A-pillar
- ❑ Qty. 2, side member
- ❑ Qty. 2, wheel housing
- ❑ Qty. 2, wing strut
- ❑ Qty. 3, wing connection piece
- ❑ 6 Nm

3 - Intermediate piece (zinc)

- ❑ AKL 381 035 50

4 - Foam piece

- ❑ Loosely inserted between wing and top of longitudinal member

5 - Wing strut

- ❑ Removing and installing
⇒ [page 10](#)

6 - Moulded foamed plastic part

- ❑ Inserted on top of longitudinal member
- ❑ Bonds to wing

7 - Hexagon nut

- ❑ One, on wing connection piece
- ❑ 6 Nm

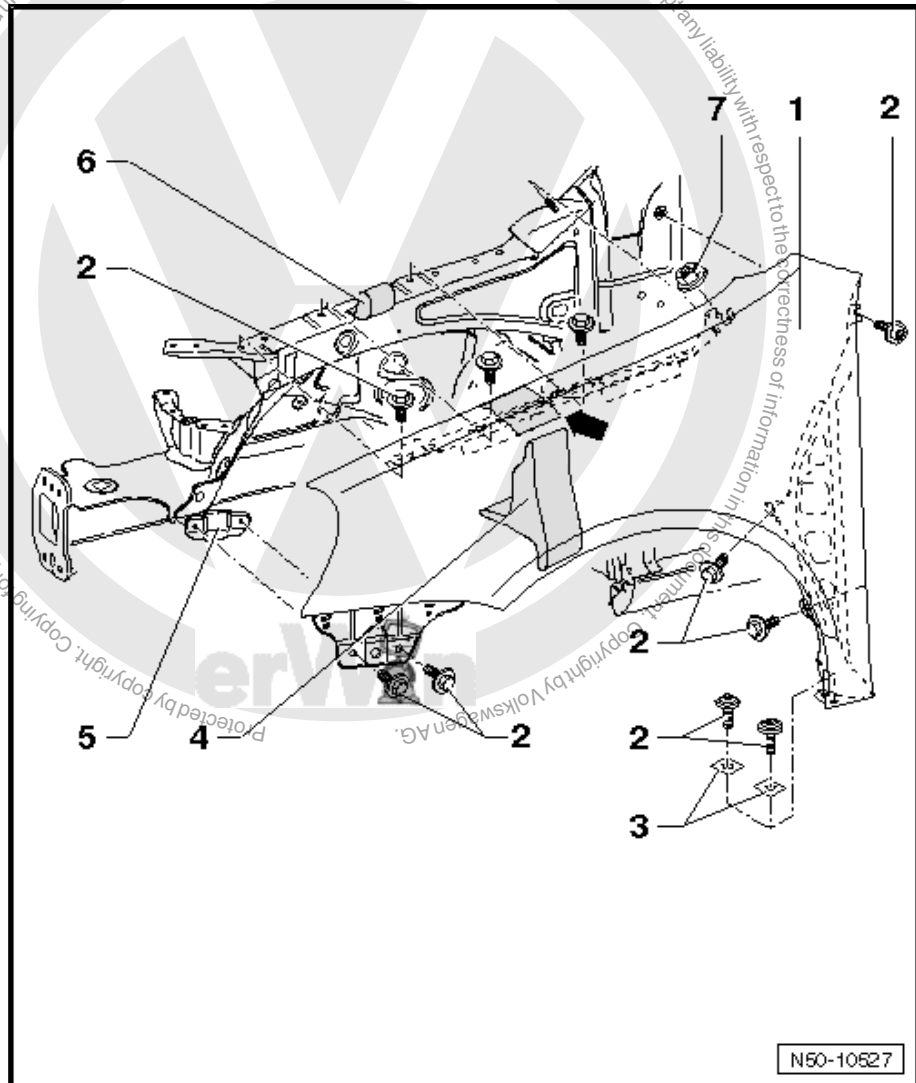

2.3 Removing and installing wing



Note

The removal and installation sequence is only described for the left wing. The removal and installation of the right wing is similar.



2.3.1 Removing

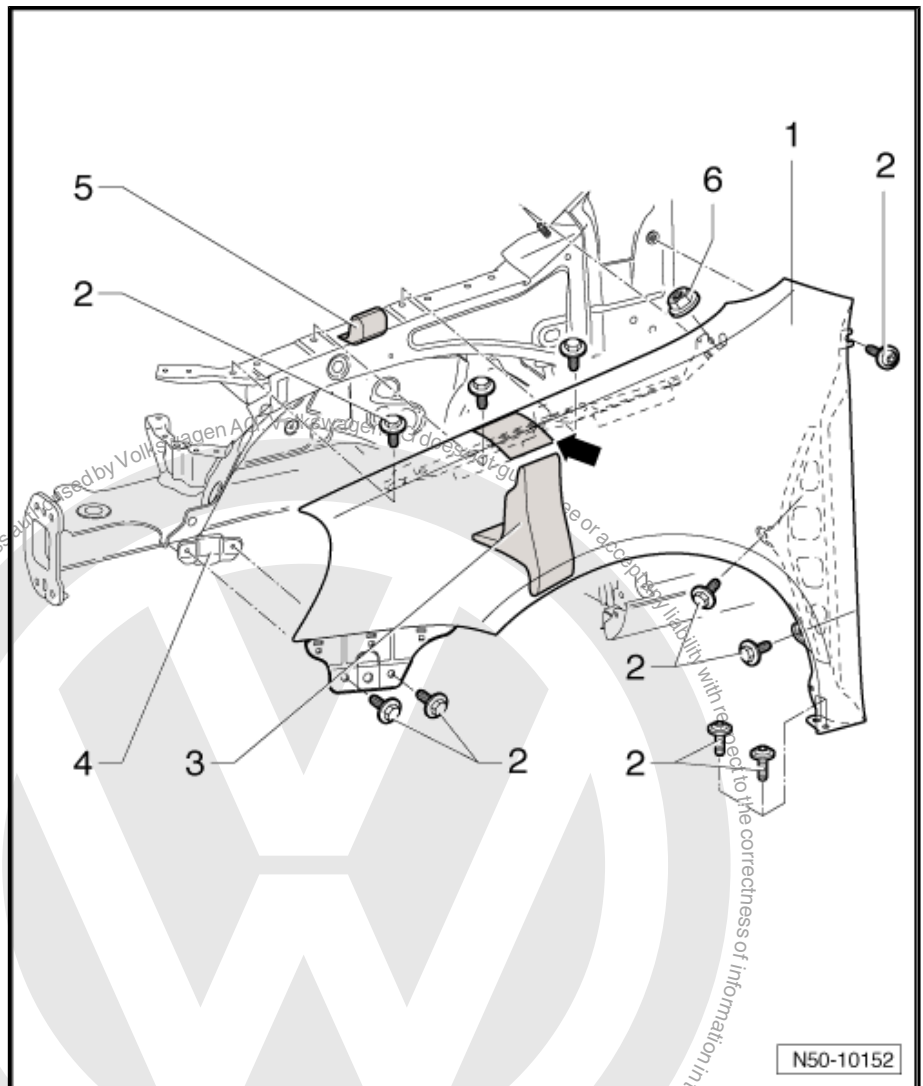

- Remove front bumper ⇒ [page 140](#) .
- Remove wheel housing liners ⇒ [page 218](#)
- Remove guide ⇒ [Item 10 \(page 143\)](#)
- Loosen hexagon nut -6- and remove bolts -2-
- Pull out moulded plastic part -3- between wing and longitudinal member.
- Lightly heat outside of wing -1- in area of moulded foam part -arrow- using hot air blower -V.A.G 1416- .
- The bonding on moulded foamed plastic part -5- releases and the wing -1- can be removed.



2.3.2 Installing

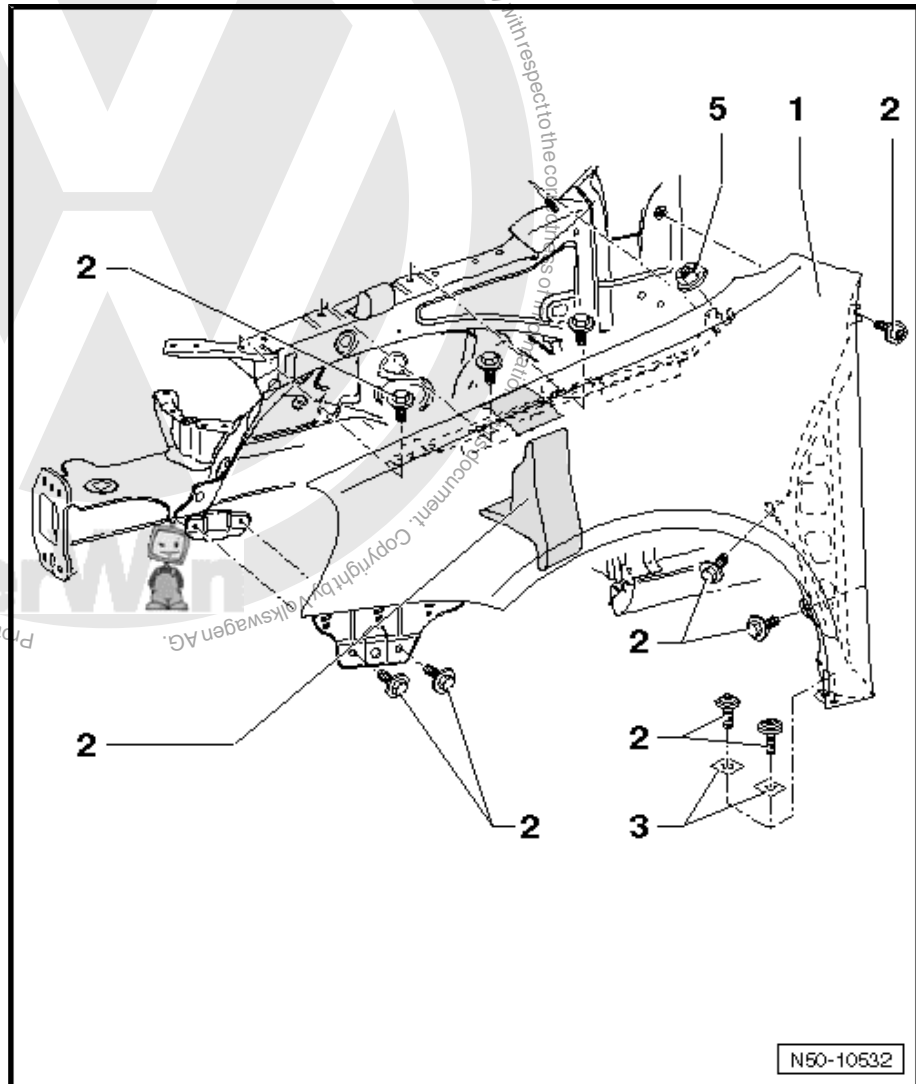

Install in reverse order of removal.

- Always insert "zinc intermediate piece AKL 381 035 50" between wing and side member.
- Specified torque for bolts -2- and hexagon nuts -5-: 6 Nm.
- Ensure that gaps are parallel and specified dimensions are maintained ⇒ Body Repairs; Rep. Gr. 00 ; Technical data; Body panel gaps/shut lines .

2.4 Removing and installing wing strut



Note

The removal and installation sequence is described for the left wing strut. The removal and installation of the right wing strut is similar.

2.4.1 Removing

- The wing has been removed.



- Remove bolts -2- and remove wing strut -1-.

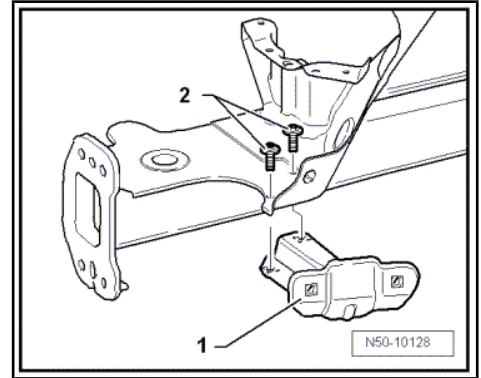

2.4.2 Installing

- Install wing strut -1-.
- Specified torque for bolts -2-: 6 Nm
- Wing and wing strut are adjusted together to bonnet and bumper => Body Repairs; Rep. Gr. 00 ; Technical data; Body gap dimensions .

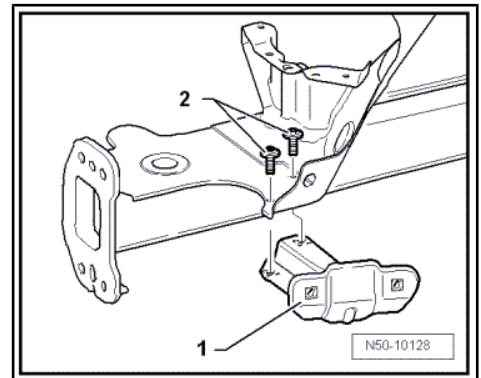



3 Noise insulation

3.1 Tools

Special tools and workshop equipment required

- ◆ Torque wrench 2...10 Nm -V.A.G 1783-

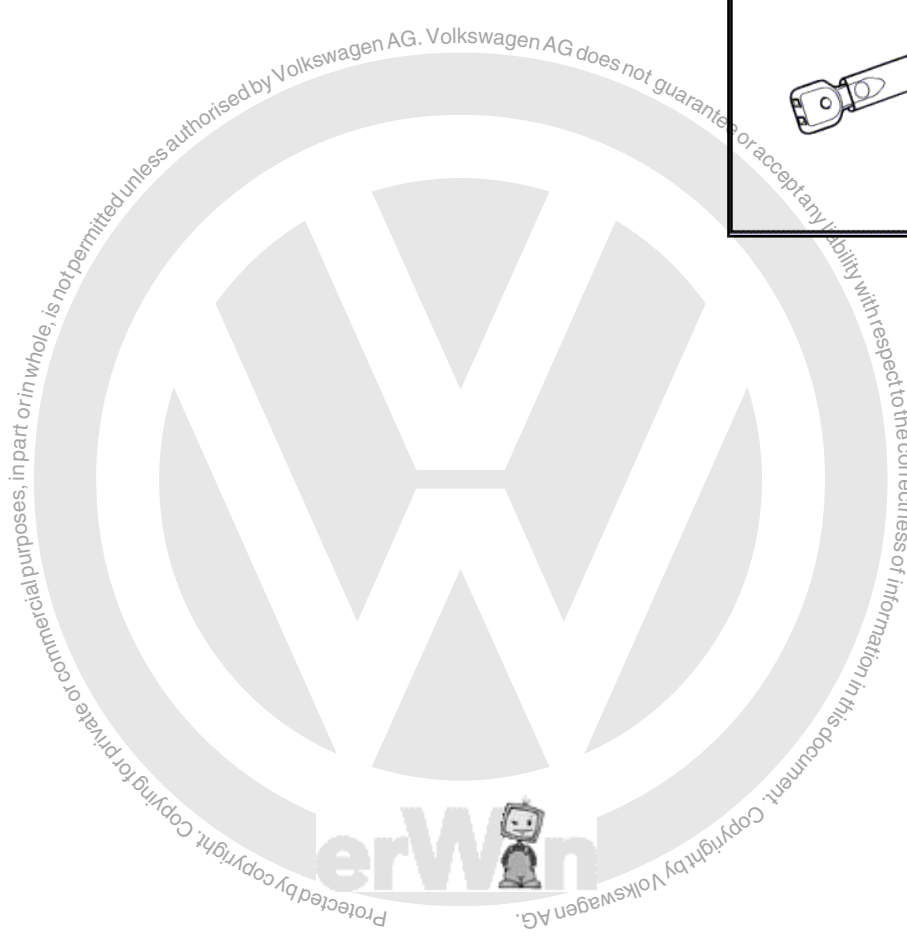
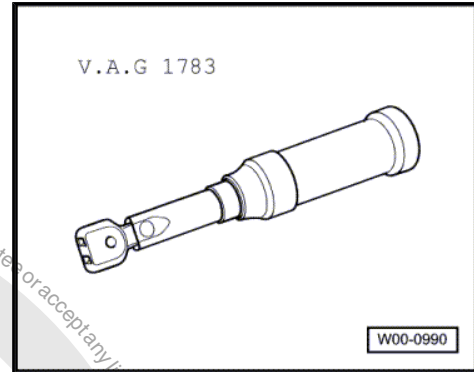



3.2 Assembly overview - noise insulation

Note

The removal and installation procedures may have to be modified slightly depending on engine fitted.

1 - Noise insulation

- Arrow points forwards
- Removing:
 - Remove bolts -2- and -3-.

2 - Bolt

- Qty. 8
- 2 Nm

3 - Bolt

- Qty. 3
- 6 Nm

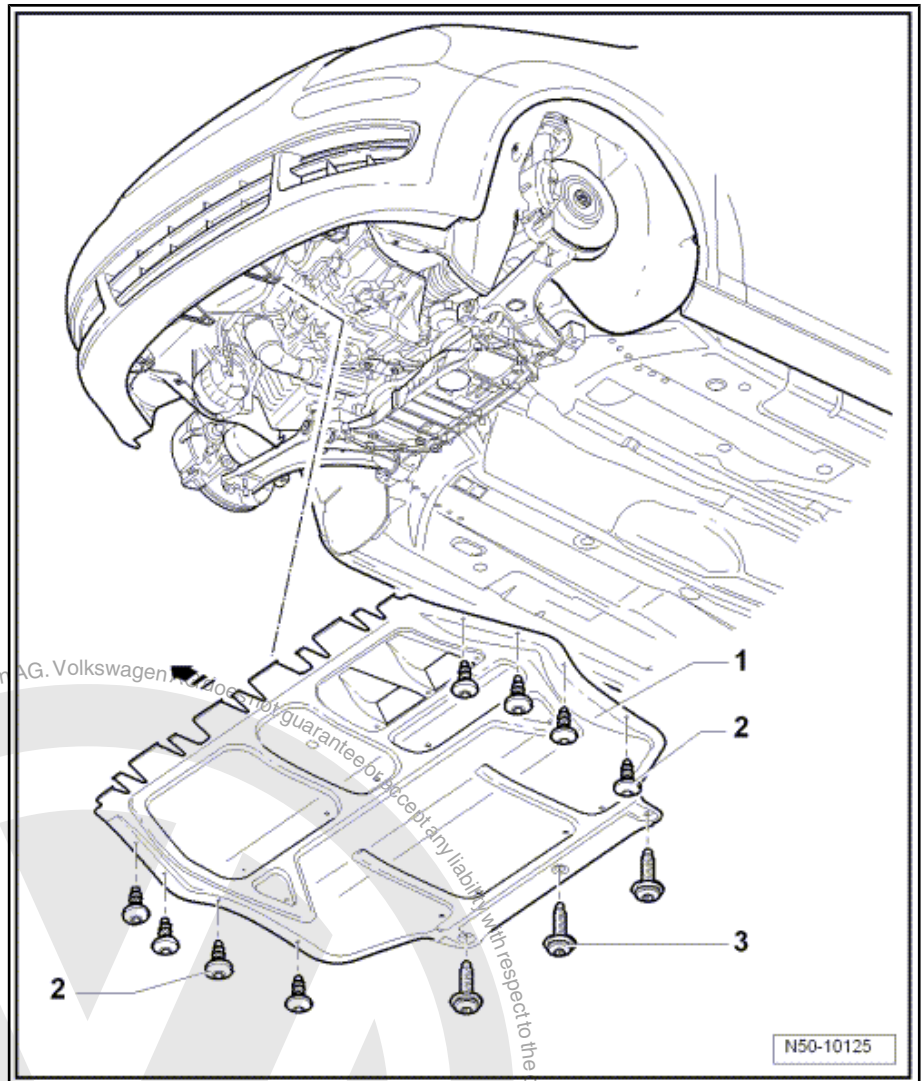



4 Underbody cladding

4.1 Tools

Special tools and workshop equipment required

- ◆ Torque wrench 2...10 Nm -V.A.G 1783-

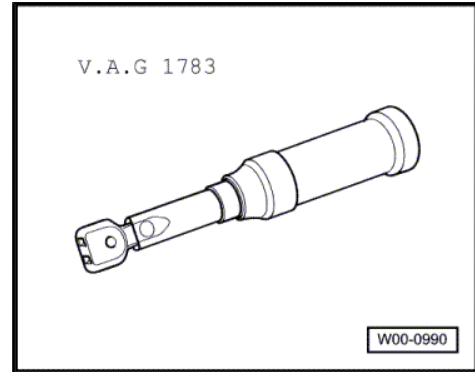



4.2 Assembly overview - underbody cladding

i Note

Only the left side is shown. The right side is similar.

1 - Underbody cladding

- Arrow points forwards
- Removing:
 - Remove hexagon nuts -2-

2 - Hexagon nut

- Qty. 8
- 1.5 Nm

3 - Rear underbody cladding

- Installed only on left-hand side.
- Removing:
 - Remove hexagon nut -4- and bolts -5-.

4 - Hexagon nut

- Qty. 1
- 1.5 Nm

5 - Bolt

- Qty. 3
- 2 Nm

6 - Cover

- Removing:
 - Remove bolts -7-.

7 - Bolt

- Qty. 2
- 2 Nm

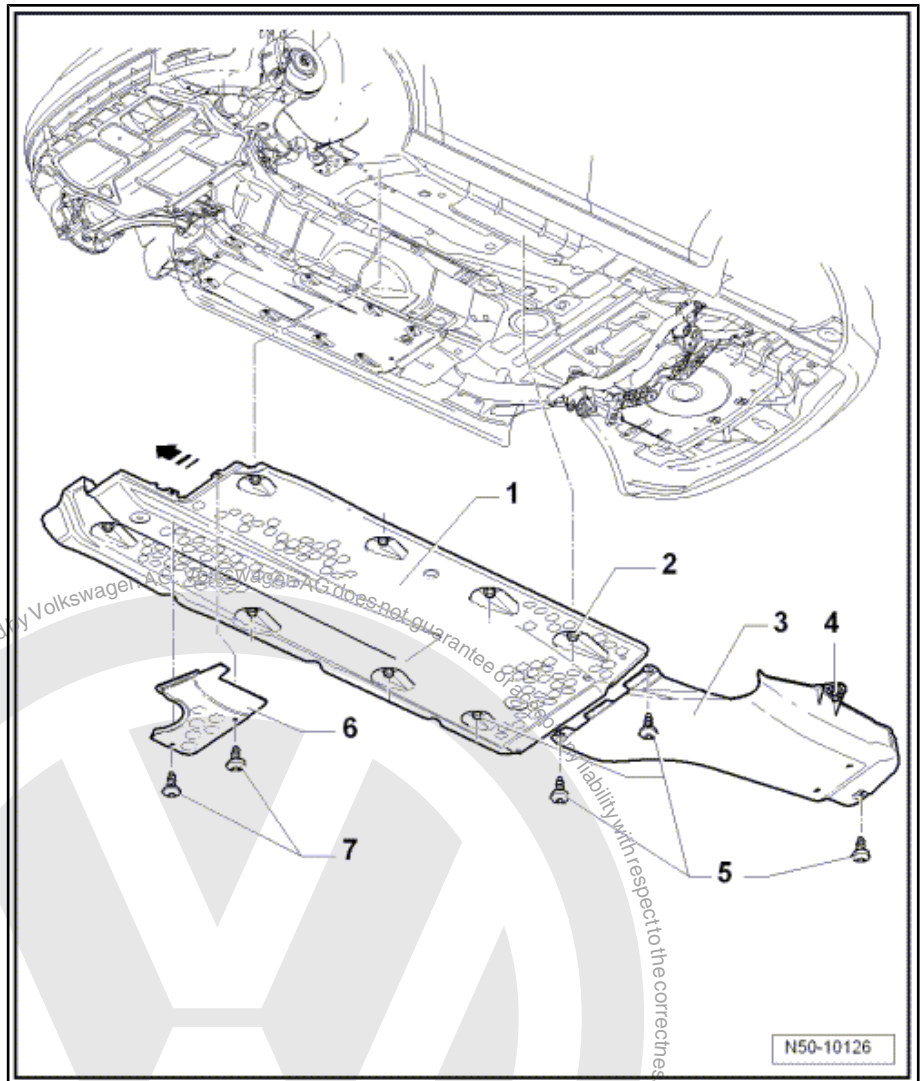



5 Plenum chamber bulkhead

5.1 Tools

Special tools and workshop equipment required

- ◆ Torque wrench 2...10 Nm -V.A.G 1783-

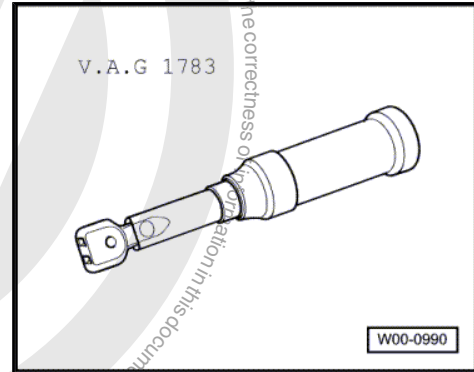

5.2 Assembly overview - plenum chamber bulkhead

1 - Plenum chamber bulkhead

2 - Hexagon nut

- 8 Nm

3 - Plenum chamber bulkhead seal

- When fitting bulkhead ensure seal is correctly fitted.

4 - Bolt

- 8 Nm

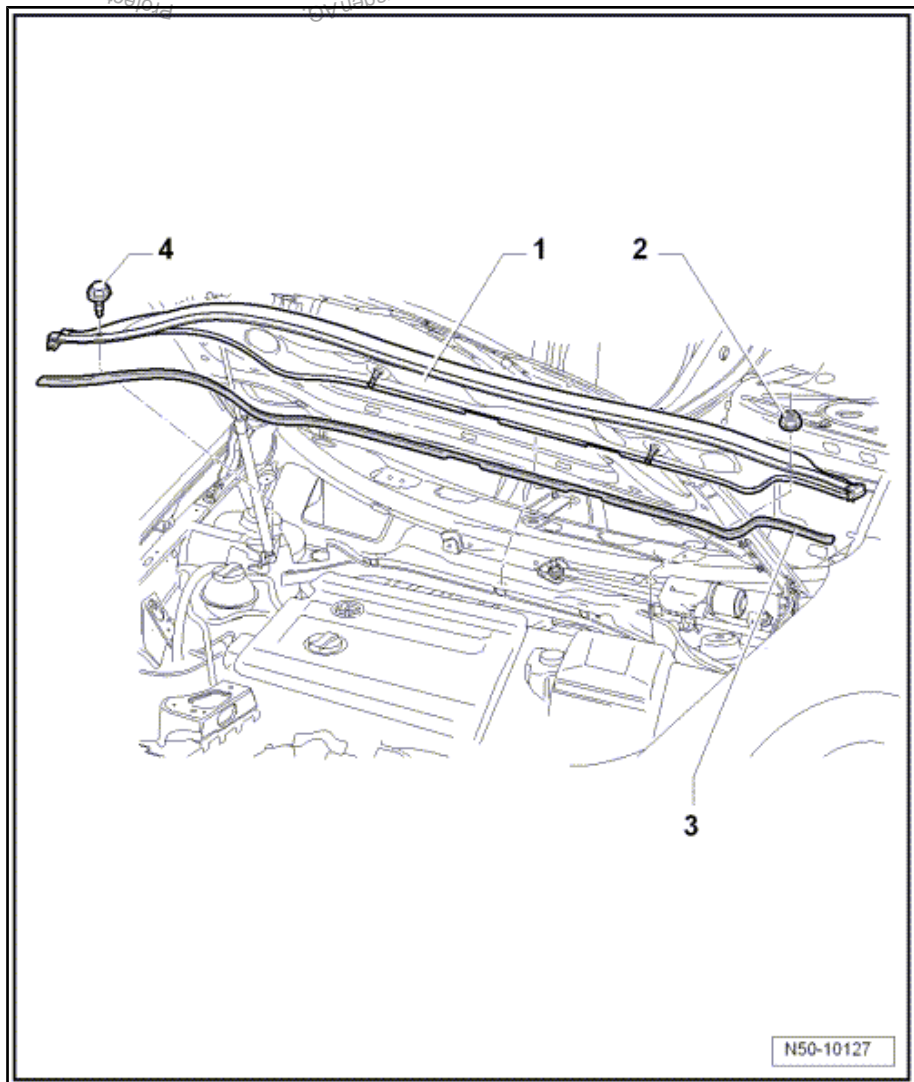



55 – Bonnet, rear lid

1 Bonnet

1.1 Tools

Special tools and workshop equipment required

- ◆ Torque wrench 5...50 Nm -V.A.G 1331-

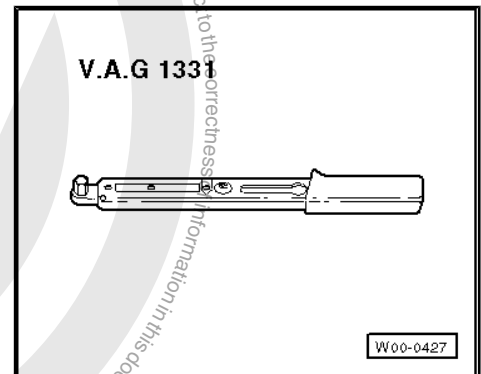

- ◆ Removal lever -80-200-

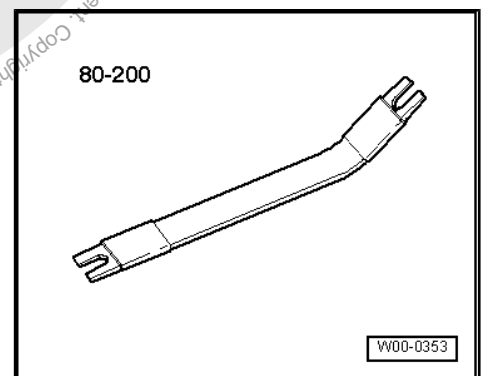



1.2 Assembly overview - bonnet

1 - Bonnet

- Removing and installing
⇒ [page 19](#)
- Adjusting ⇒ [page 26](#)

2 - Adjustment buffer

- Qty. 2
- Adjusting ⇒ [page 26](#)

3 - Stop buffer

- Qty. 2

4 - Insulation

- Removing and installing
⇒ [page 22](#)

5 - Guide

- Qty. 2

6 - Hinge

- Removing and installing
⇒ [page 20](#)
- Adjusting ⇒ [page 26](#)

7 - Gas strut

- Removing ⇒ [page 20](#)
- Releasing gas
⇒ [page 20](#)

8 - Seal

- Secured with 17 clips to
inside of bonnet

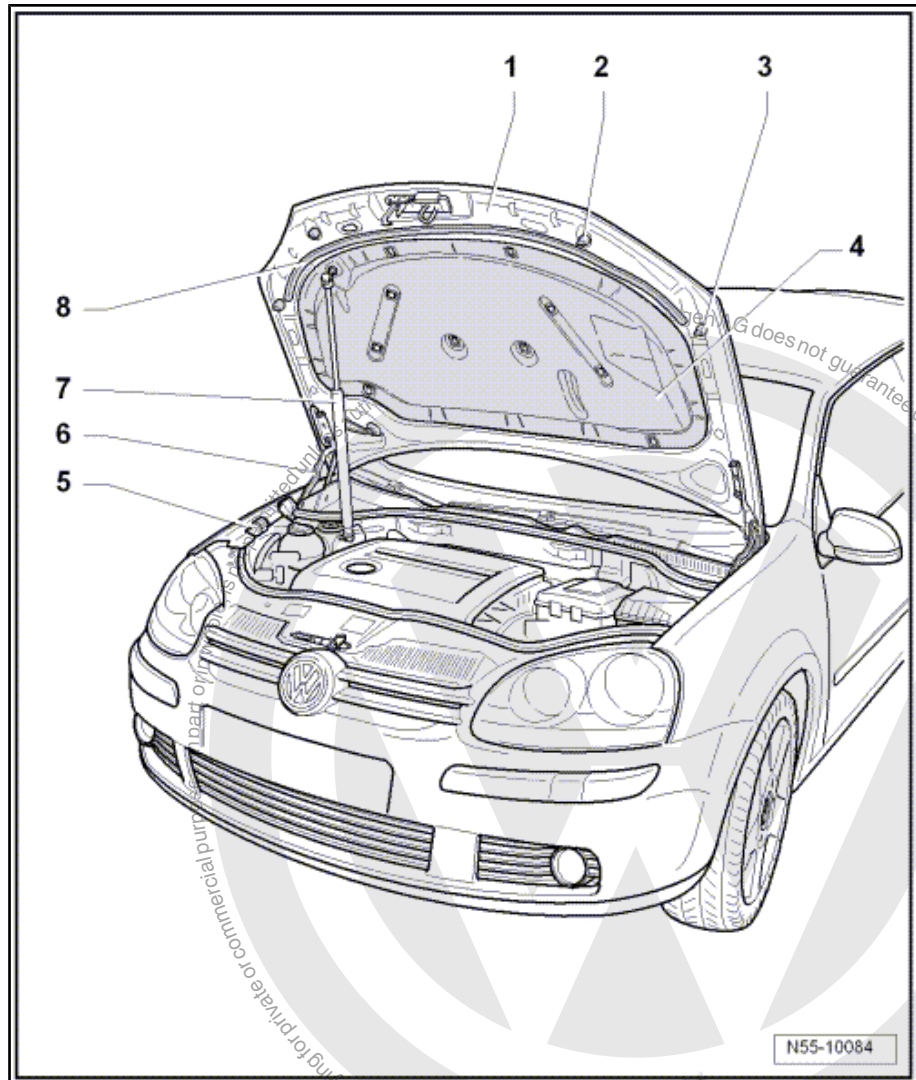



1.3 Removing and installing bonnet

1.3.1 Removing

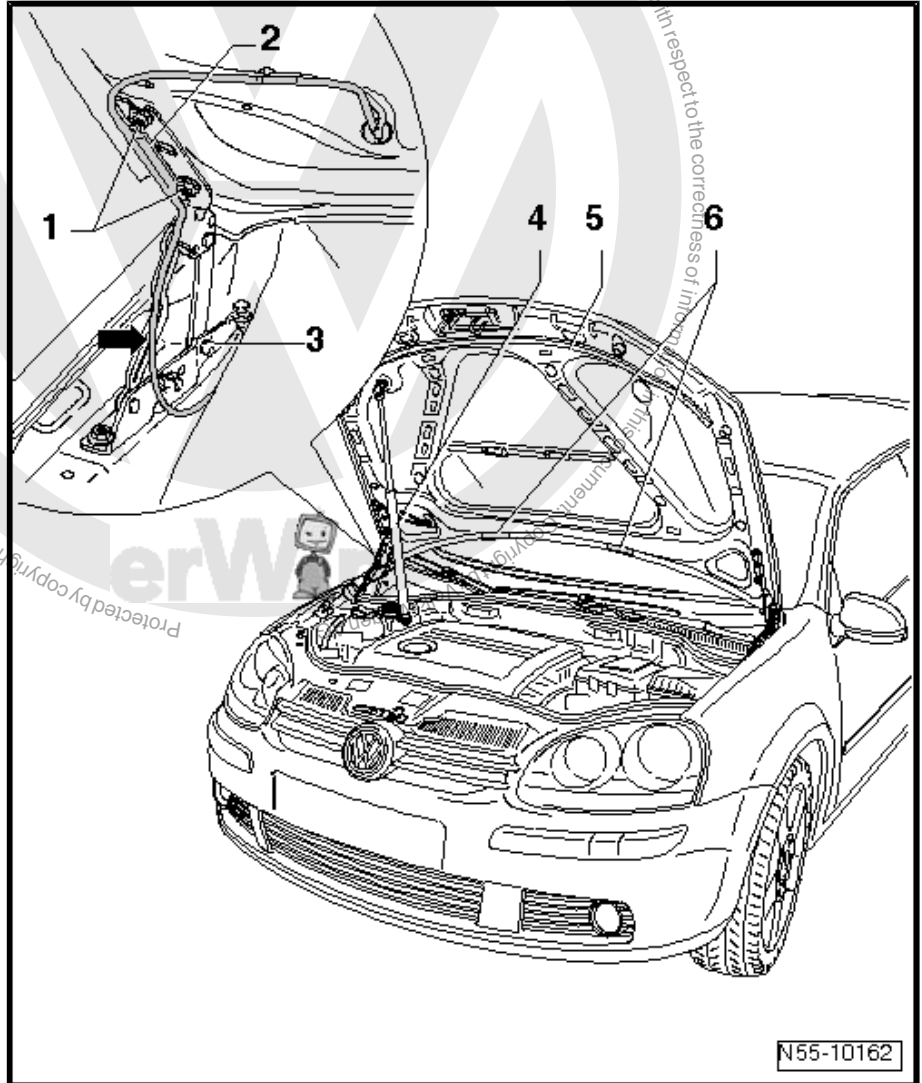

- Remove left and right washer jets -6- ⇒ Electrical system; Rep. Gr. 92 ; Window wiper/washer system; Windscreen washer system; Removing and installing windscreen washer system jets .
 - Unclip line -2- from hinge -3- and bonnet -5-.
 - Pull line -2- out through aperture in bonnet -5-.
 - Loosen hexagon nuts -1- on left and right (do not remove).
- Further dismantling requires the help of a second mechanic.
- Disconnect gas strut -4- at bonnet -5- ⇒ [page 20](#) .
 - Now remove hexagon nuts -1- and lift lid -5- out of hinges -3-.

1.3.2 Installing

Install in reverse order of removal.



- Specified torque for bonnet hexagon nut: 22 Nm.
- Adjusting bonnet -1- => [page 26](#) .
- Route line -2- in an arc -arrow-. If line is installed twisted it will be kinked.

1.4 Removing gas strut

- Open rear lid and support it.
- Position a small screwdriver beneath spring clip -2-.
- Raise spring clip -2- until it can be moved over ball socket in direction of -arrow-.
- Pull gas struts -1- from ball-head pins -3- and -4-.

After removing gas strut -1-, slide spring clip -2- back immediately.



WARNING

Proceed with care if gas strut is reused. Spring clip must not be levered completely out of ball socket, as it will otherwise be damaged. Gas strut will spring out of mounting, causing damage or injury to operator.

- Specified torque for ball-head pins -3- and -4-: 22 Nm.
- Releasing gas from gas strut => [page 20](#)

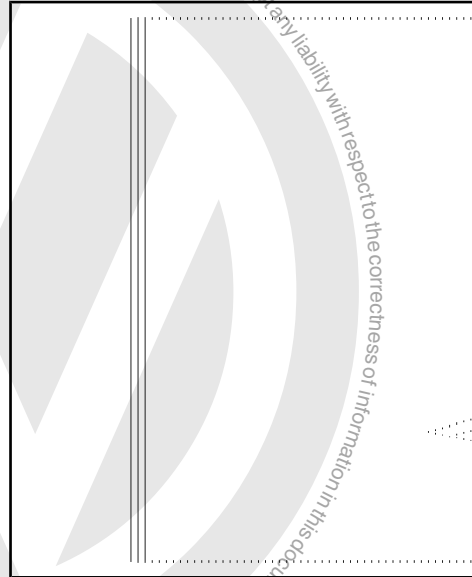

1.5 Releasing gas from gas strut

- Clamp gas strut in vice in area x = 50 mm.



WARNING

Clamp gas strut only within area -x-; otherwise danger of accident!

- Saw through cylinder of gas strut within first third of cylinder's overall length using piston rod end of cylinder as reference point.

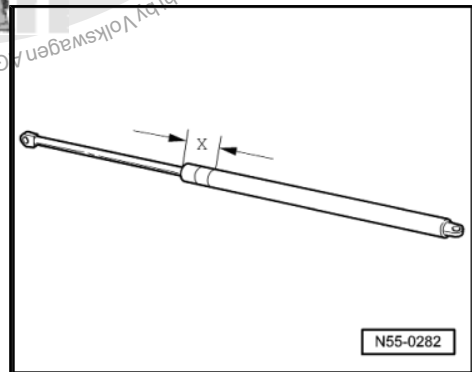

Note

- ◆ Wear eye protection when sawing.
- ◆ Cover area of saw cut with a cloth.
- ◆ Dispose of oil and cloth via existing disposal channels.

1.6 Removing and installing flap hinge



Note

The removal and installation sequence is only described for the left hinge. The removal and installation of the right hinge is similar.



1.6.1 Removing

- Remove bonnet => [page 19](#) .
- Remove bolts -2- and remove bonnet hinge -1-.

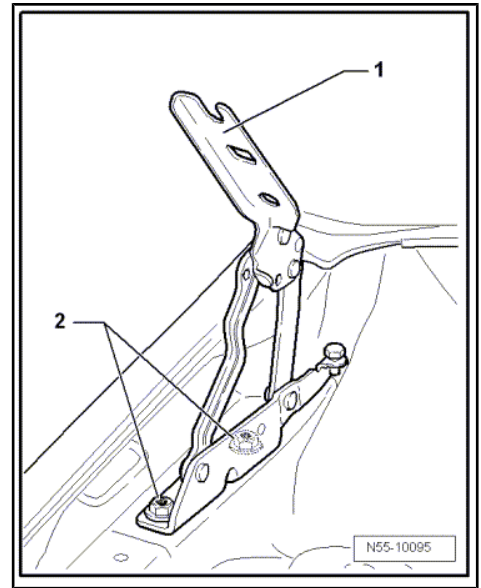

1.6.2 Installing

- Install flap hinge -1-.
- Specified torque for bolts -2-: 22 Nm.
- Install flap => [page 19](#) .

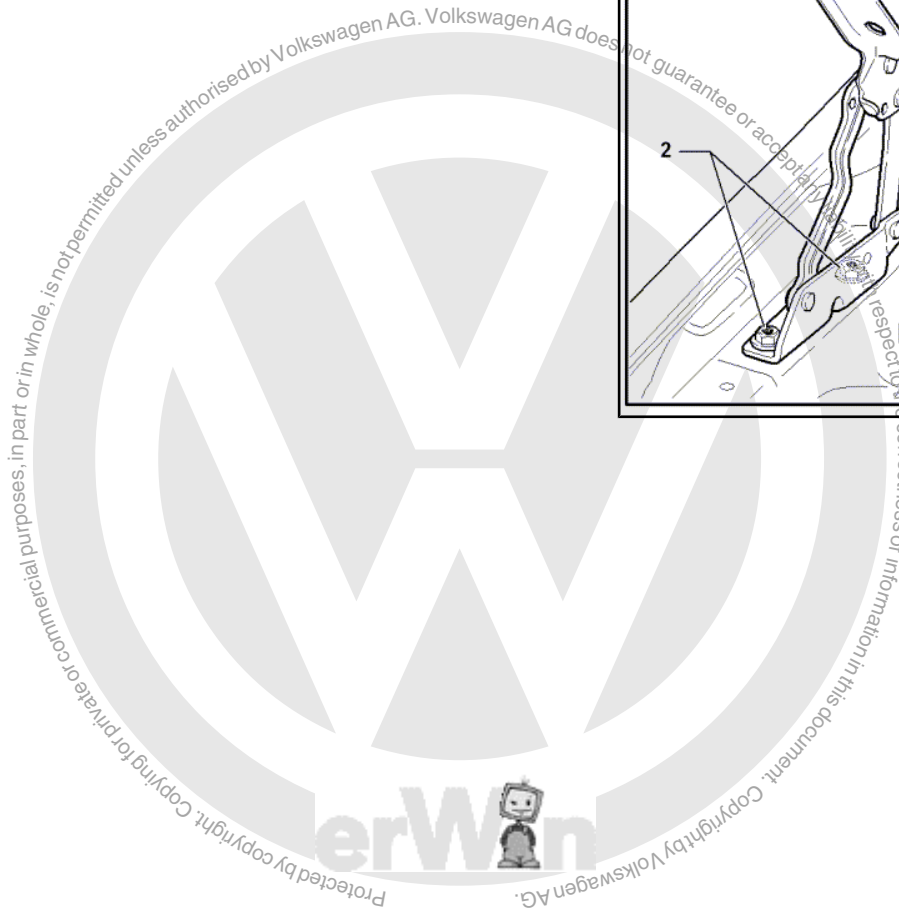
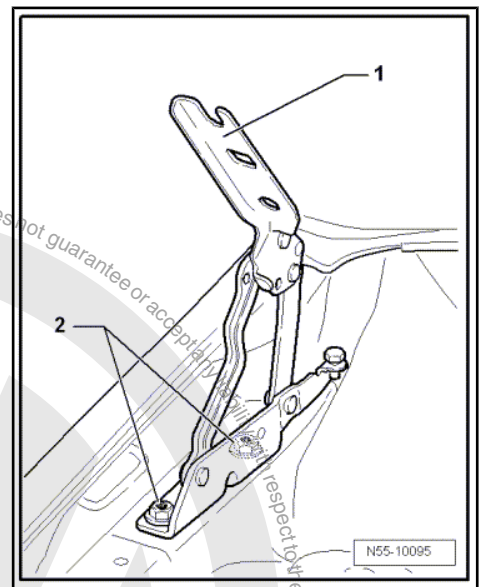



1.7 Removing and installing insulation

1.7.1 Removing

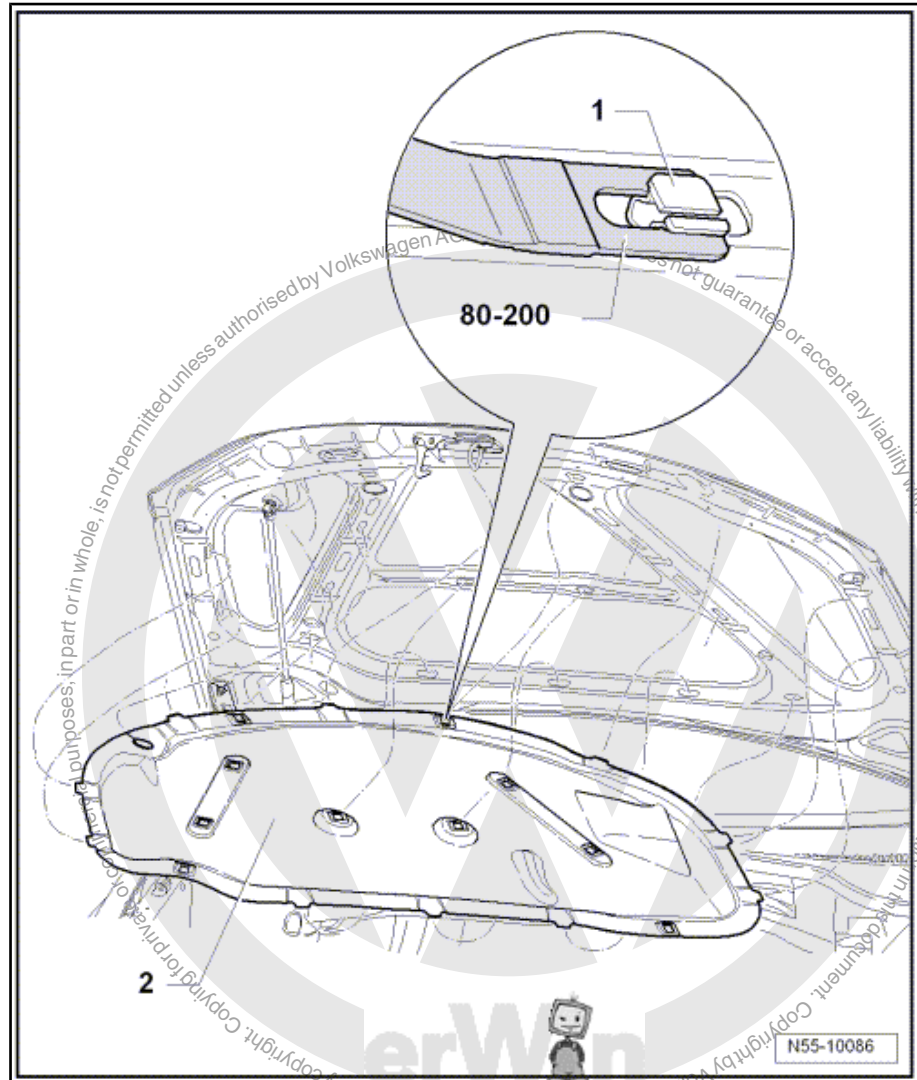

- Lever retaining clips -1- (Qty. 10) out of insulation -2- using removal lever -80-200- .
- Pull insulation -2- out of elongated holes.



1.7.2 Installing

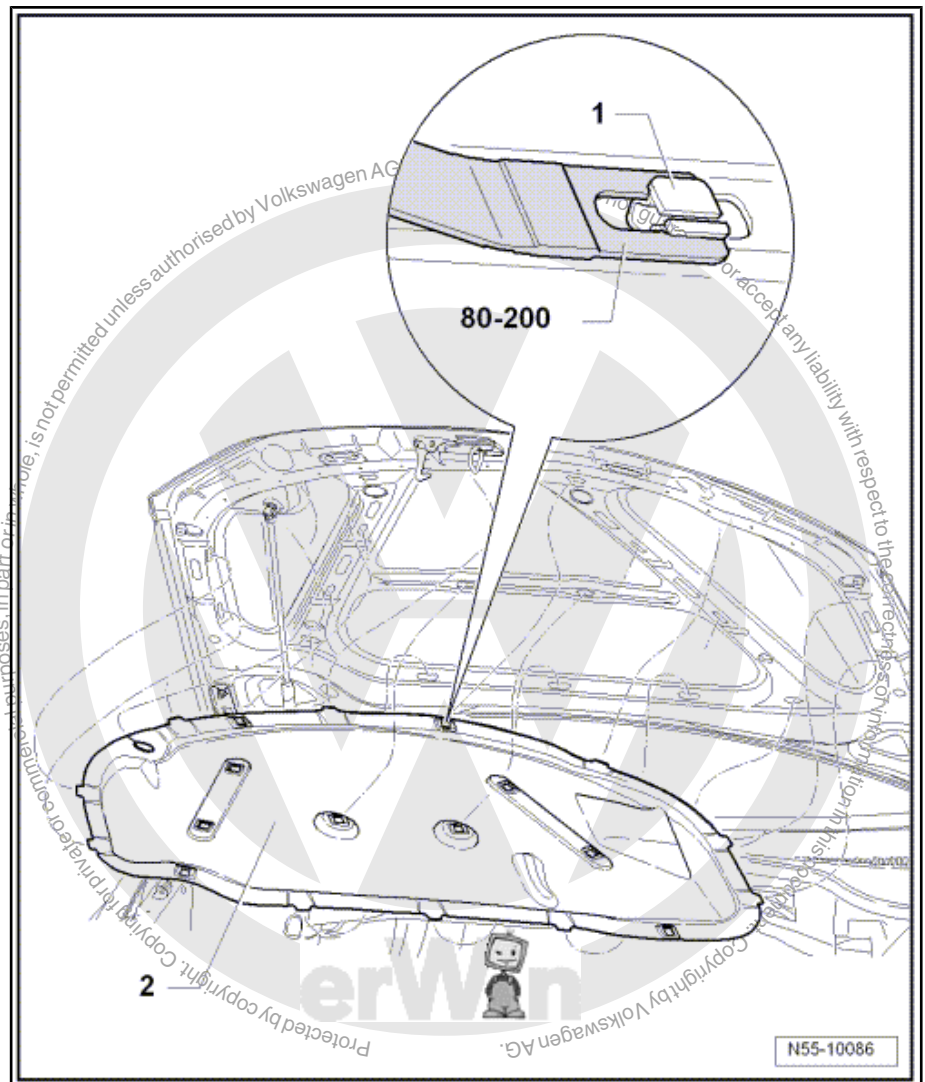

- Push insulation -2- underneath gas strut and place assembly tongues in elongated holes.
- Engage all retaining clips -1- (Qty. 10) in insulation -2-.
- When installing insulation -2- ensure that retaining clips -1- are fitted with wider side outwards.



1.8 Assembly overview - bonnet latch and release components

1 - Arrester

- Removing:
 - Remove bolts -2- and remove latch hook.
- Adjusting:
 - Adjustment is carried out by moving arrester to left or right in elongated holes.

2 - Bolt

- Qty. 3
- 10 Nm

3 - Expanding nut

- Qty. 2

4 - Bearing bracket

5 - Bowden cable

- Clipped into bearing bracket

6 - Bolt

- Qty. 2
- 1.5 Nm

7 - Release lever

- Removing and installing
[⇒ page 28](#)

8 - Bowden cable

- Clipped onto wheel housing and lock carrier.

9 - Bowden cable coupling

- Separating [⇒ page 26](#)

10 - Bonnet lock

- Removing and installing [⇒ page 25](#)
- Adjusting [⇒ page 27](#)

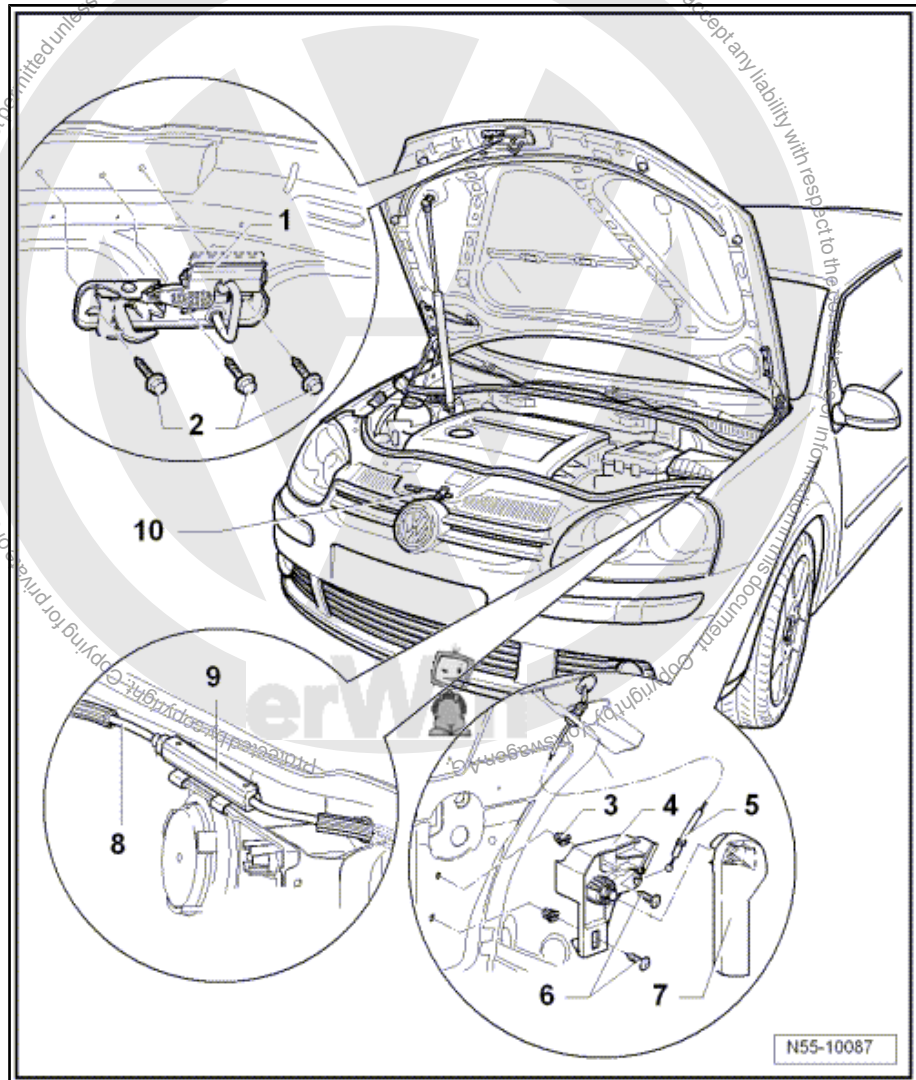



1.9 Removing and installing bonnet lock

1.9.1 Removing

- Open bonnet.

Depending on model

- Remove radiator grille ⇒ [page 230](#) ,
- Remove GTI radiator grille ⇒ [page 233](#) ,
- Remove R32 radiator grille ⇒ [page 237](#) .

All models

- Separating Bowden cable ⇒ [page 26](#)
- Separate connector -5- for bonnet contact switch -F 266- .

The connector is secured over the right headlight.

- Remove bolts -4- (Qty. 3) on lock carrier -3- and remove bonnet lock -1- upwards.
- To unclip Bowden cable -2-, press tab and Bowden cable together -arrows-.
- The fastening is released and the Bowden cable -2- can be removed from the bonnet lock -1-.

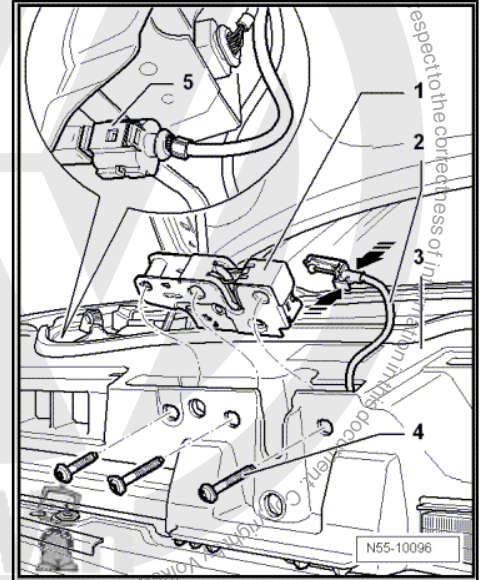

1.9.2 Installing

- Clip Bowden cable -2- into bonnet lock -1-.
- Install bonnet lock -1- in lock carrier -3-.
- Specified torque for bolts -4-: 12 Nm.
- Connect connector -5- for bonnet contact switch -F 266- .
- Install Bowden cable -2- ⇒ [page 26](#) .
- Adjust bonnet lock ⇒ [page 27](#) .
- Before closing the bonnet, check the function of the release lever and Bowden cable.

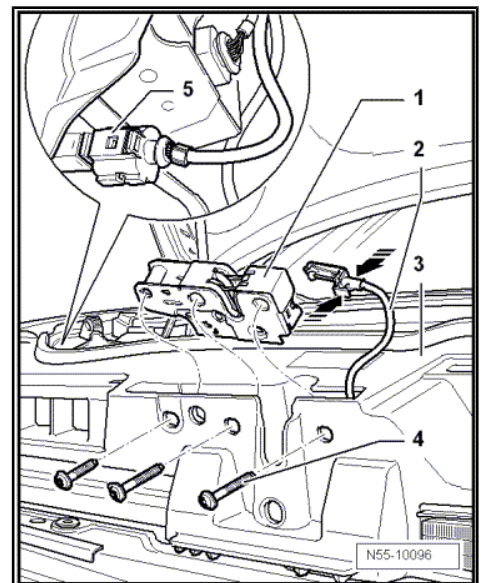



1.10 Separating Bowden cable

- Open bonnet.
- Unclip Bowden coupling -1- above headlight on driver side of lock carrier -2-.
- Open Bowden cable coupling -1- upwards and remove Bowden cable -3- in -direction of arrow- out of Bowden cable coupling.

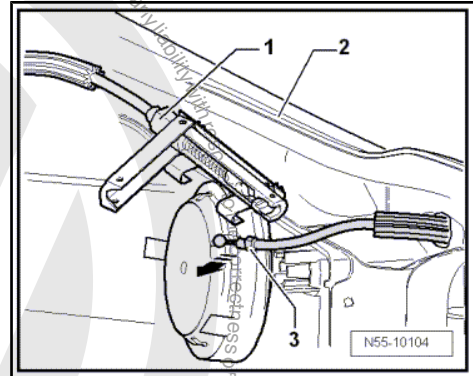

Note

When installing, ensure that the Bowden cable sleeve is inserted correctly and the coupling engages.

- Before closing the bonnet, check the function of the release lever and Bowden cable.

1.11 Adjusting bonnet

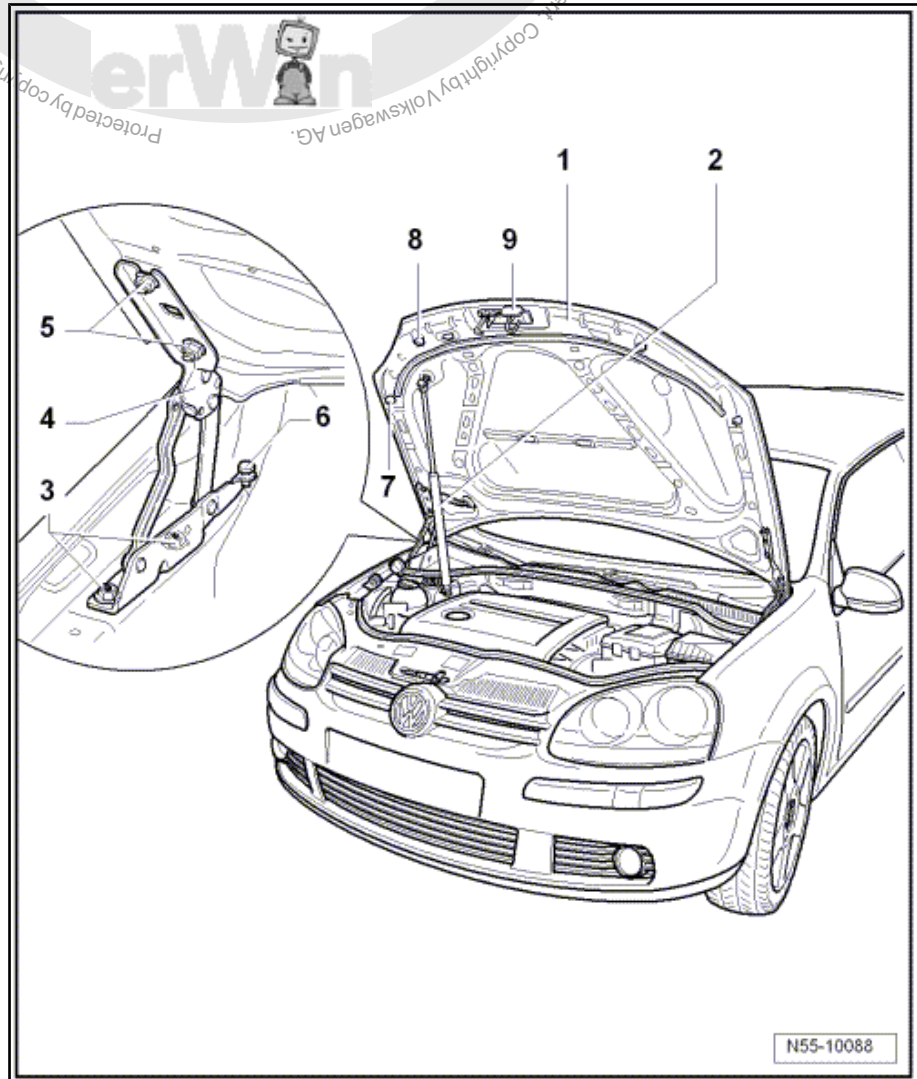

- For initial adjustment of bonnet, -1-, the vehicle must be standing on the ground and the latch hook be removed.



- Remove arrester -9- ⇒ [Item 1 \(page 24\)](#) .
- Disconnect gas strut -2- at bonnet -1- ⇒ [page 20](#) .
- By loosening hexagon nuts -5- and bolt -3- on both bonnet hinges -4- (do not remove) the bonnet -1- can be aligned between wings.
- The rear part of the bonnet -1- can be adjusted both sides to the wing height by using the adjustment screws -6-.
- The stop buffers -7- (Qty. 2) are not used for adjustment. They have the function of stabilising and damping the bonnet -1-.
- The front part of the bonnet -1- can be adjusted to wing height by using the adjustment buffers -8- (Qty. 2).
- Ensure that gaps are uniform ⇒ Body Repairs; Rep. Gr. 00 ; Technical data; Body gaps/shut lines .
- Carry out corrosion protection measures on hinge -4-, hexagon nuts -5- and bolts -3- following assembly or adjustment procedures.
- After adjusting bonnet -1-, install and adjust arrester ⇒ [Item 1 \(page 24\)](#) .

1.11.1 Adjusting bonnet lock

- If gaps change when the bonnet is closed, a minor correction can be made via bonnet lock and arrester.
- Removing radiator grille ⇒ [page 230](#)
- If bolts -1- are now loosened, bonnet gap dimensions can be corrected or adjusted ⇒ Body Repairs; Rep. Gr. 00 ; Technical data; Body gaps/shut lines .
- Specified torque for bolts -1-: 12 Nm.
- Adjusting arrester ⇒ [Item 1 \(page 24\)](#)

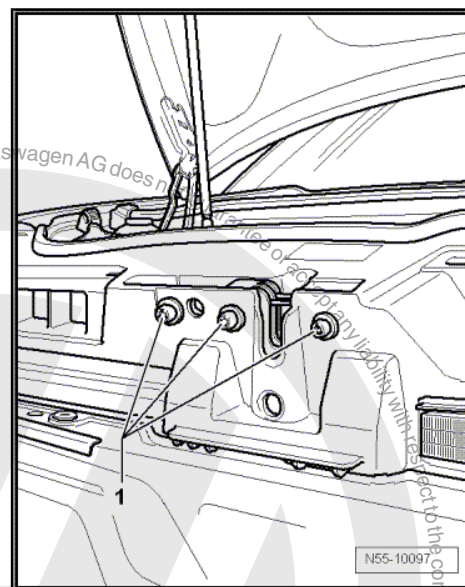

Protected by copyright. Copying for private or commercial purposes, in part or in whole, is not permitted unless authorised by Volkswagen AG. Volkswagen AG does not accept the correctness of information in this document. Copyright by Volkswagen AG.



1.12 Removing and installing release lever

1.12.1 Removing

- Pull release lever -1- and release bonnet.
- Insert a small screwdriver in gap between release lever -1- and clip -2-.
- Lever clip -2- out of release lever -1- and pull off release lever.

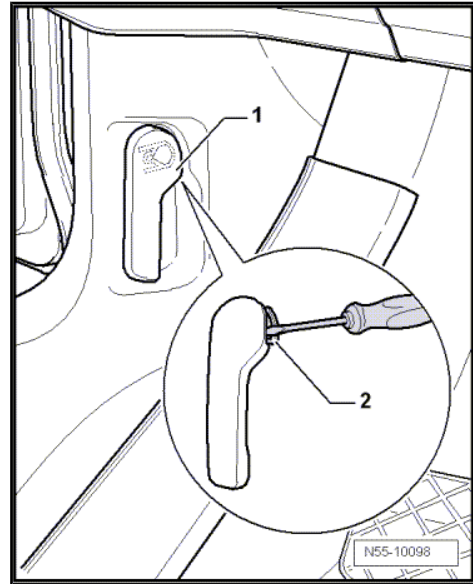

1.12.2 Installing

- Slide clip -2- completely into release lever -1-.
- Then press release lever -1- onto mounting in mounting bracket and fasten release lever.
- Before closing the bonnet, check the function of the release lever and Bowden cable.

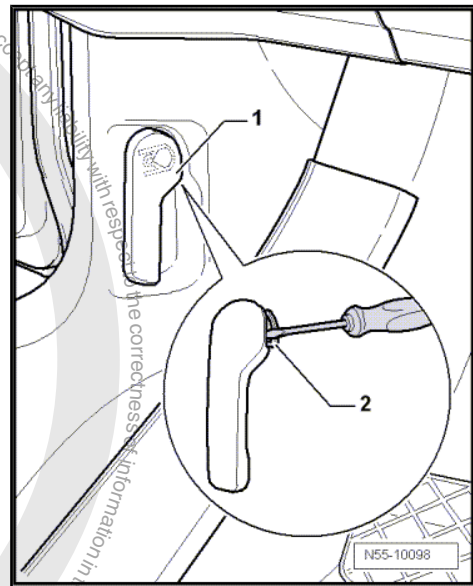



2 Rear lid

2.1 Tools

Special tools and workshop equipment required

- ◆ Torque wrench 5...50 Nm -V.A.G 1331-

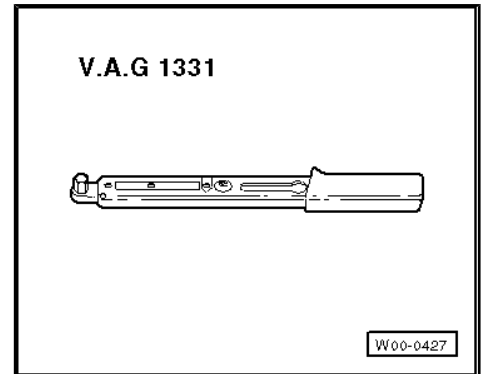

2.2 Assembly overview - rear lid

1 - Lid

- Removing and installing
⇒ [page 30](#)
- Adjusting ⇒ [page 34](#)

2 - Rear lid lock

- Removing and installing
⇒ [page 39](#)

3 - Adjustment buffer

- Left and right
- Adjusting ⇒ [page 35](#)

4 - Gas strut

- Removing ⇒ [page 31](#)
- Releasing gas
⇒ [page 31](#)

5 - Hinge

- Removing and installing
⇒ [page 31](#)

6 - Striker pin

- Removing and installing
⇒ [page 34](#)
- Adjusting ⇒ [page 35](#)

7 - Cap

- Left and right
- Stop for adjustment buffer

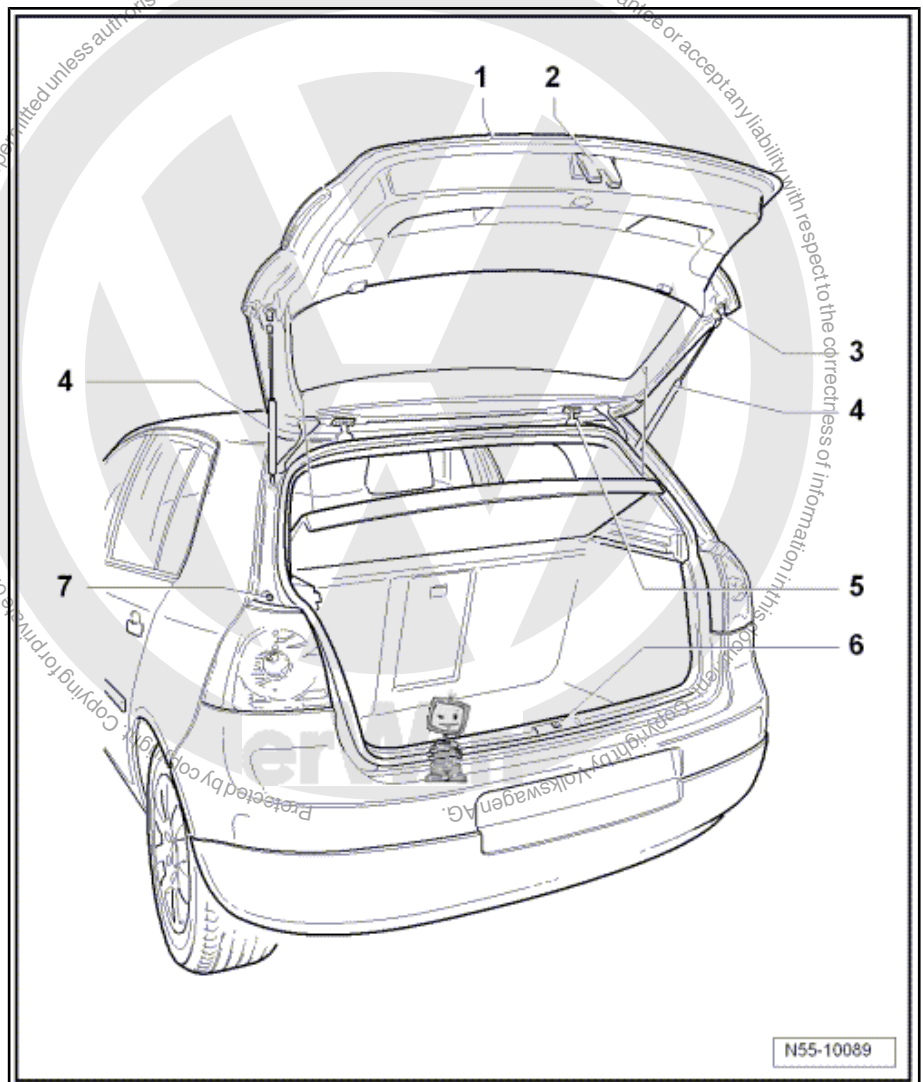



2.3 Removing and installing rear lid

2.3.1 Removing

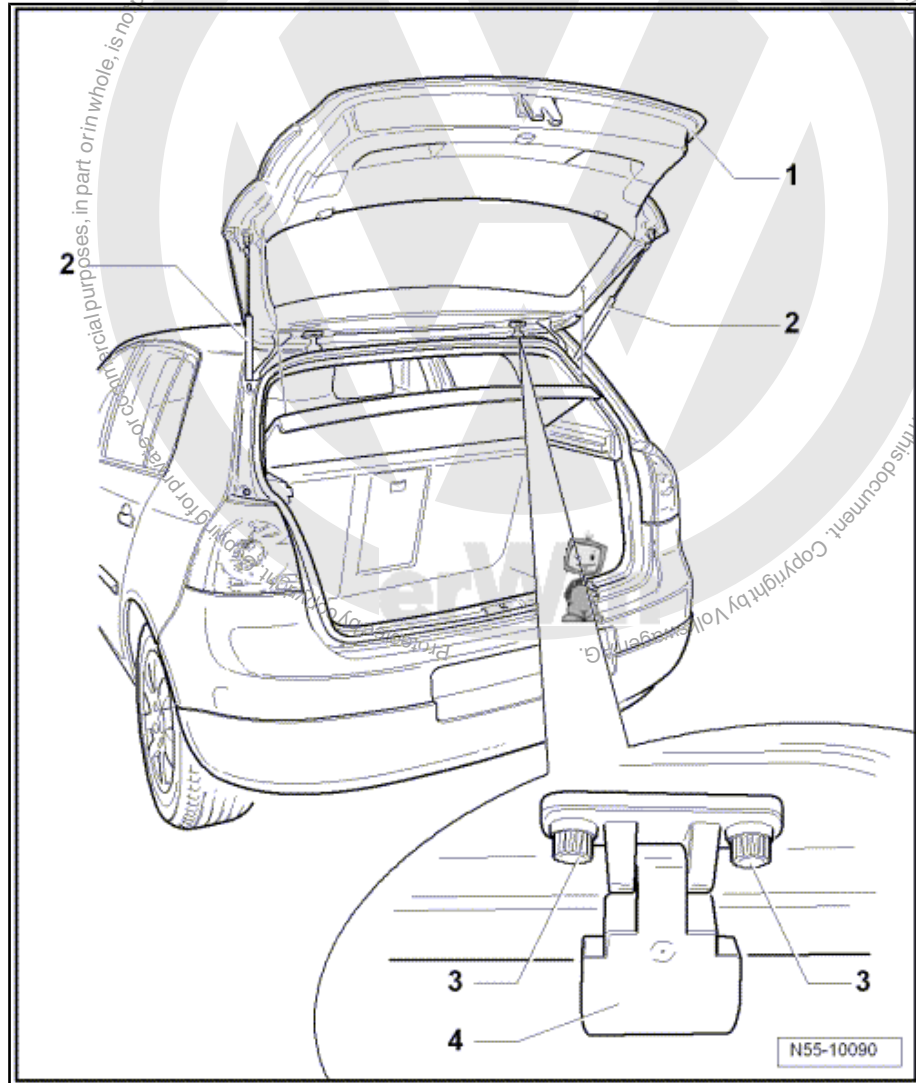

- Open rear lid -1-.
- Remove rear lid trim ⇒ General body repairs, interior; Rep. Gr. 70 ; Trims and insulation; Rear lid trim .
- Separate connectors for all electrical components and pull hose off rear window wash and wipe system.
- Guide hose and lines out through opening.
- Loosen bolts -3- for hinges -4- on left and right (do not remove).

Further dismantling is possible only with the help of a second mechanic.

- Detach gas struts -2- on left and right of lid -1- ⇒ [page 31](#) .
- Now remove bolts -3- and remove rear lid -1-.

2.3.2 Installing

Installation is carried out in reverse order of removal.



- Specified torque for rear lid bolts: 10 Nm.
- Adjusting lid ⇒ [page 34](#) .
- Before closing rear lid, check function of lid release components.

2.4 Removing gas strut

- Open rear lid and support it.
- Position a small screwdriver beneath spring clip -2-.
- Raise spring clip -2- until spring clip can be moved over ball socket in -direction of arrow-.
- Pull gas struts -1- from ball-head pins -3- and -4-.

After removing gas strut -1-, slide spring clip -2- back immediately.



WARNING

Proceed with care if gas strut is reused. Spring clip must not be levered completely out of ball socket, as it will otherwise be damaged. Gas strut springs out of mounting and causes damage or injury to operator.

- Specified torque for ball-head pins -3- and -4-: 21 Nm.
- Releasing gas from gas strut ⇒ [page 31](#)

2.5 Releasing gas from gas strut

- Clamp gas strut in vice in area x = 50 mm.



WARNING

Clamp gas strut only within area -x-; otherwise danger of accident!

- Saw through cylinder of gas strut within first third of cylinder's overall length using piston rod end of cylinder as reference point.



Note

- ◆ Wear eye protection when sawing.
- ◆ Cover area of saw cut with a cloth.
- ◆ Dispose of oil and cloth via existing disposal channels.

2.6 Removing and installing rear lid hinges



Note

Removal and installation is described for the right rear lid hinge. Follow same instructions for the left rear lid hinge as appropriate.

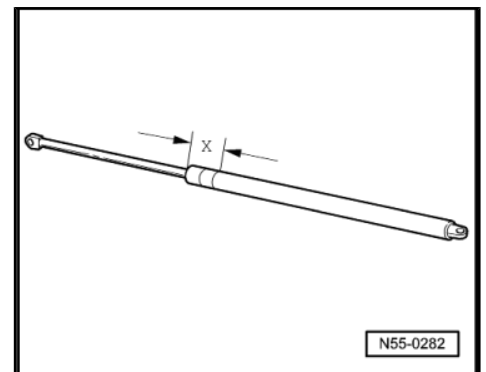
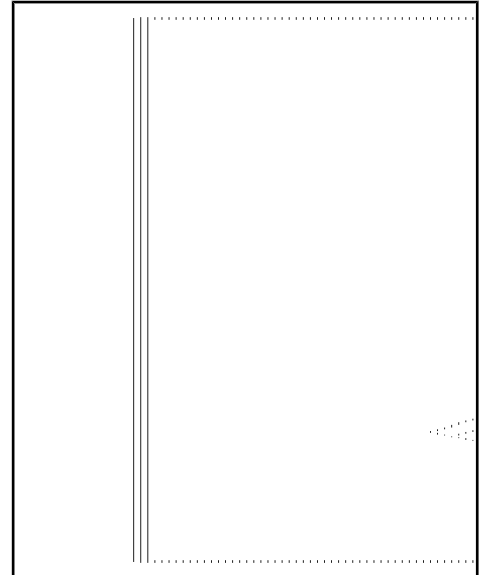

N55-0282



2.6.1 Removing

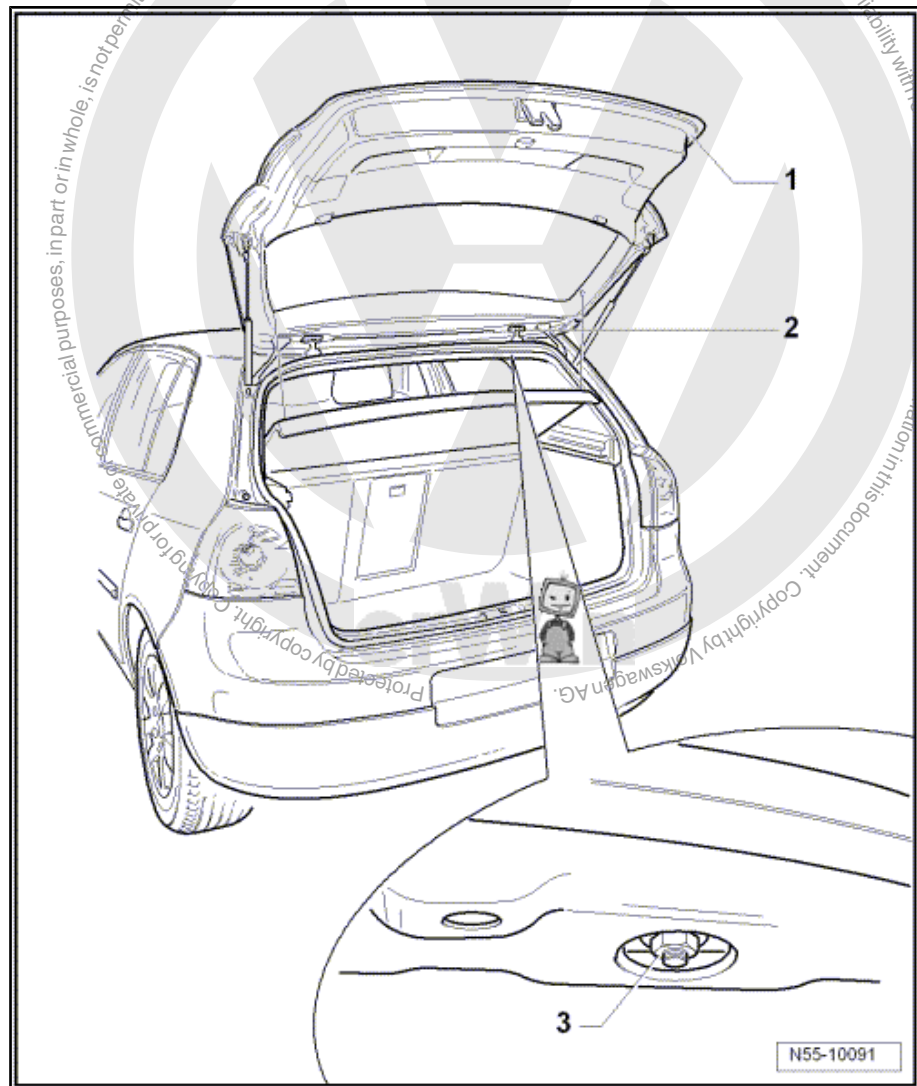

- Remove rear lid -1- ⇒ [page 30](#) .
- Lower rear of moulded headlining ⇒ General body repairs, interior; Rep. Gr. 70 ; Trims, insulation; Roof trims; Removing and installing moulded headlining .
- Remove hexagon nut -3- and remove rear lid hinge -2- from roof bracing.



2.6.2 Installing



After installing rear lid -1- tighten hexagon nut -3- for rear lid hinge -2- again to 24 Nm.

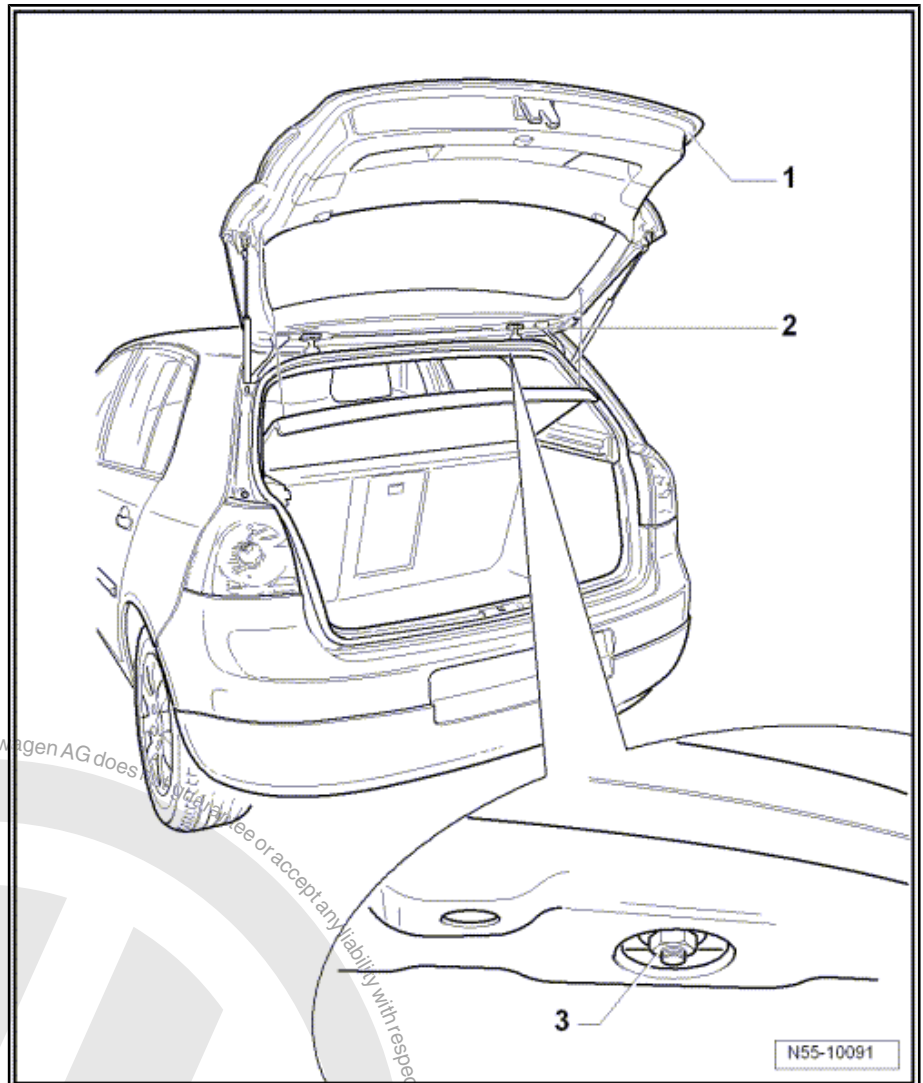

- Install rear lid hinge -2- and tighten hexagon nut -3- to 24 Nm.
- Install rear lid -1- ⇒ [page 30](#) .
- Retighten hexagon nuts -3- to 24 Nm after completing assembly procedure.
- Install moulded headlining ⇒ General body repairs, interior; Rep. Gr. 70 ; Trims, insulation; Roof trims; Removing and installing moulded headlining .



2.7 Removing and installing striker pin

2.7.1 Removing

- Remove lock carrier cover ⇒ General body repairs, interior; Rep. Gr. 70 ; Luggage and load area compartment trim; Removing and installing lock carrier cover .
- Remove bolts -1- and remove striker pin.

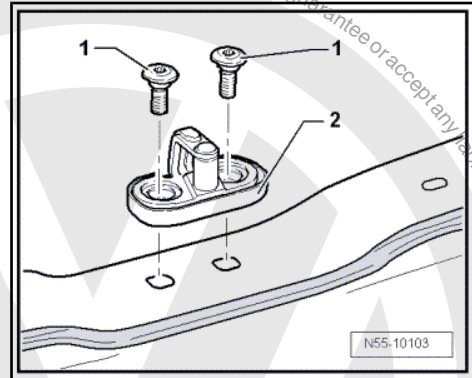

2.7.2 Installing

- Install striker pin -2-.
- Specified torque for bolts -1-: 23 Nm.
- Adjust striker pin ⇒ [page 35](#)

Further installation is performed in the reverse order of removal.

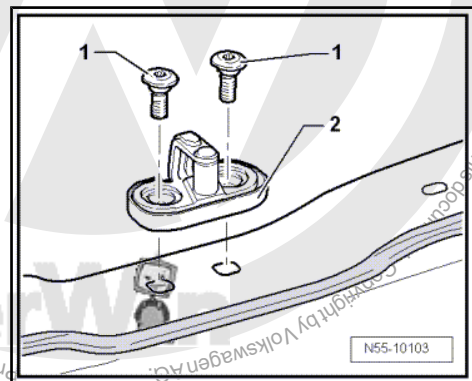

2.8 Adjusting lid



Note

- ◆ *Vehicle must be standing on the ground to perform the basic adjustment of the rear lid.*
- ◆ *The rear lid lock is bolted directly to the rear lid. It does not have elongated holes, so it cannot be adjusted.*
- ◆ *Adjusting buffers cannot be used to adjust rear lid as they are in some other vehicles. They have the function of stabilising and damping the rear lid.*

In conclusion, the rear lid adjustment is described in several steps.

Use the setting gauge -3371- ⇒ Body Repairs; Rep. Gr. 00 ; Technical data; Body gap dimensions to check or adjust the gap dimensions.

- Remove gas strut ⇒ [page 31](#) .
- Adjust rear lid at striker pin ⇒ [page 35](#) .
- Adjust rear lid on rear lid hinges by loosening bolts -3- ⇒ [page 30](#) .
- Adjust rear lid on rear lid hinges by loosening hexagon nut -3- ⇒ [page 32](#) .



- Adjust adjustment buffer => [page 35](#) .

i Note

The lid is adjusted correctly if the gaps/shut lines are even all around, the lid is not too deep or too high and all contours align when the lid closed.

2.8.1 Adjusting striker pin

- Remove lock carrier cover => General body repairs, interior; Rep. Gr. 70 ; Luggage and load area compartment trim; Removing and installing lock carrier cover .
- Loosen striker pin -2-.
- Move striker pin -2- to rearmost position -arrow- and tighten bolts -1-.
- Close rear lid and check adjustment.
- By loosening bolts -1- it is possible to slide striker pin -2- within over-sized holes.
- Specified torque for bolts -1-: 23 Nm.

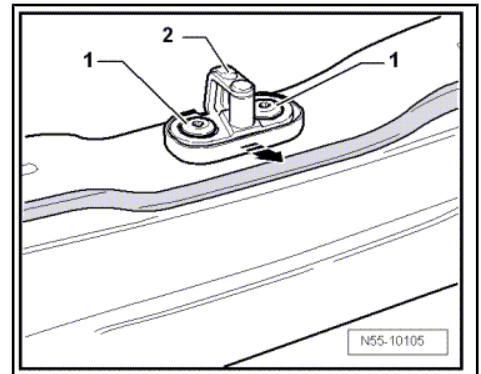

2.8.2 Adjusting adjustment buffer

i Note

Only the adjustment for the right adjustment buffer is described. The adjustment for the left adjustment buffer is similar.

- Loosen clamping bolt -2- until it is visible in rubber buffer.
- Now pull detent slide -1- out of adjustment buffer.

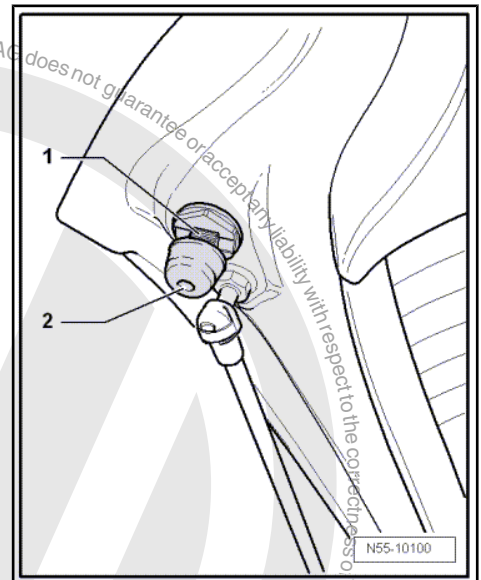

Protected by copyright. Copying for private or commercial purposes, in part or in whole, is not permitted unless authorised by Volkswagen AG. Volkswagen AG does not guarantee or accept any liability with respect to the correctness of information in this document. Copyright by Volkswagen AG.



- Adjust detent slide to dimension -a = 12.5 mm-.
- Close rear lid to detent position with light pressure at centre of lid.

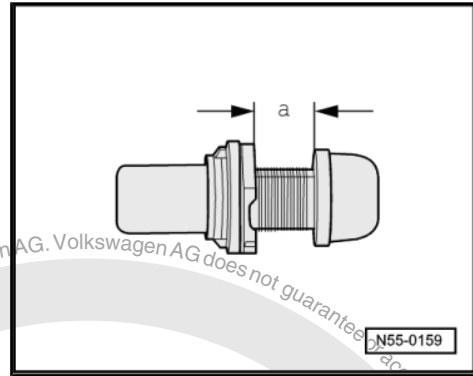

- Open rear lid again.
- Screw in adjustment buffer clamping screw -1- to a depth of dimension -a = 25 mm-.
- Check setting.

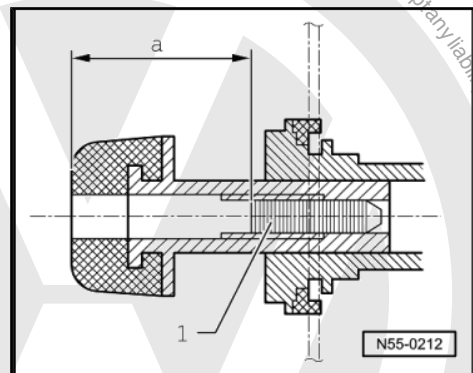

Protected by copyright. Copying for private or commercial purposes, in part or in whole, is not permitted unless authorised by Volkswagen AG. Volkswagen AG does not guarantee the accuracy or completeness of the information in this document. Copyright by Volkswagen AG.



2.9 Assembly overview - rear lid latch and release components

1 - Release element with button E234

- ❑ Removing and installing
⇒ [page 37](#)

2 - Bolt

- ❑ Qty. 5
- ❑ 4 Nm

3 - Emergency release

- ❑ Emergency release can be found through an aperture in the rear lid trim

4 - Lid lock

- ❑ Removing and installing
⇒ [page 39](#)

5 - Lid lock connector

6 - Retaining bracket

7 - Release element connector

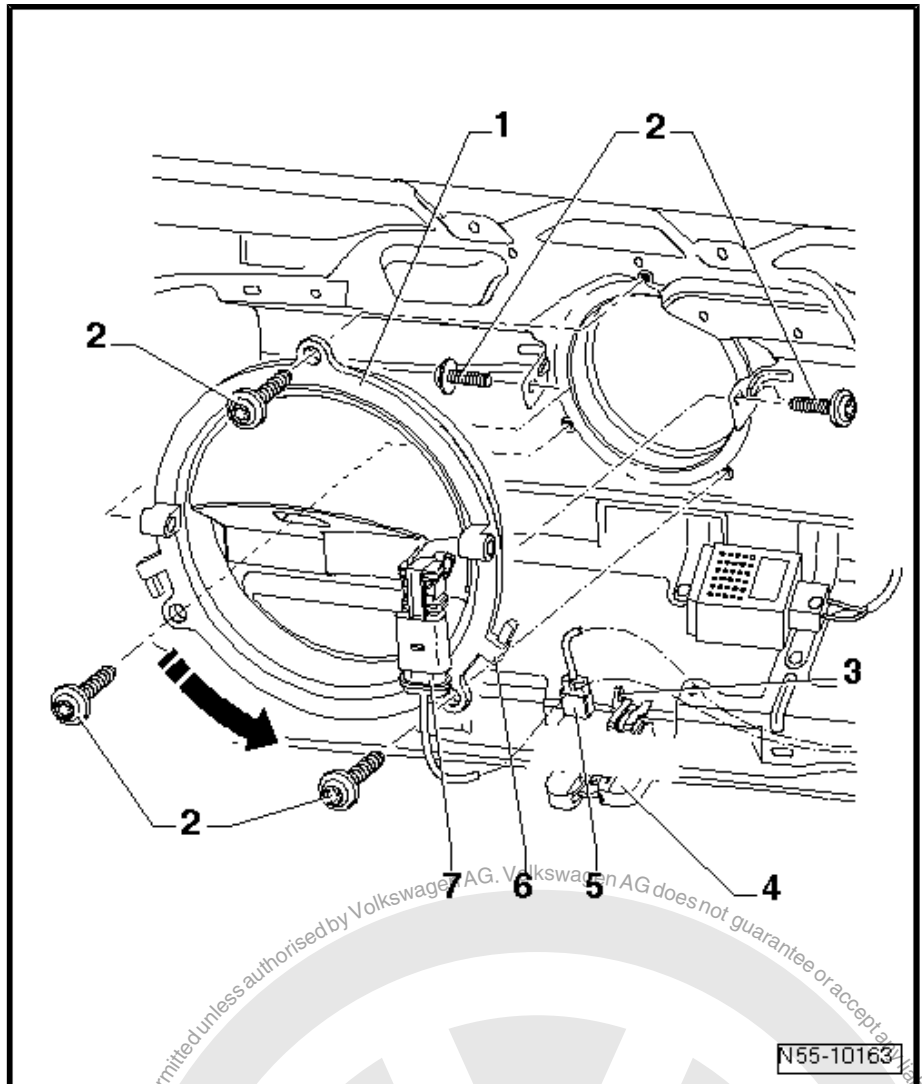

2.10 Removing and installing release element



Note

If rear lid will not open, it can be opened by hand using the emergency release -3- on rear lid lock -4-. Emergency release can be found through an aperture in the rear lid trim



2.10.1 Removing

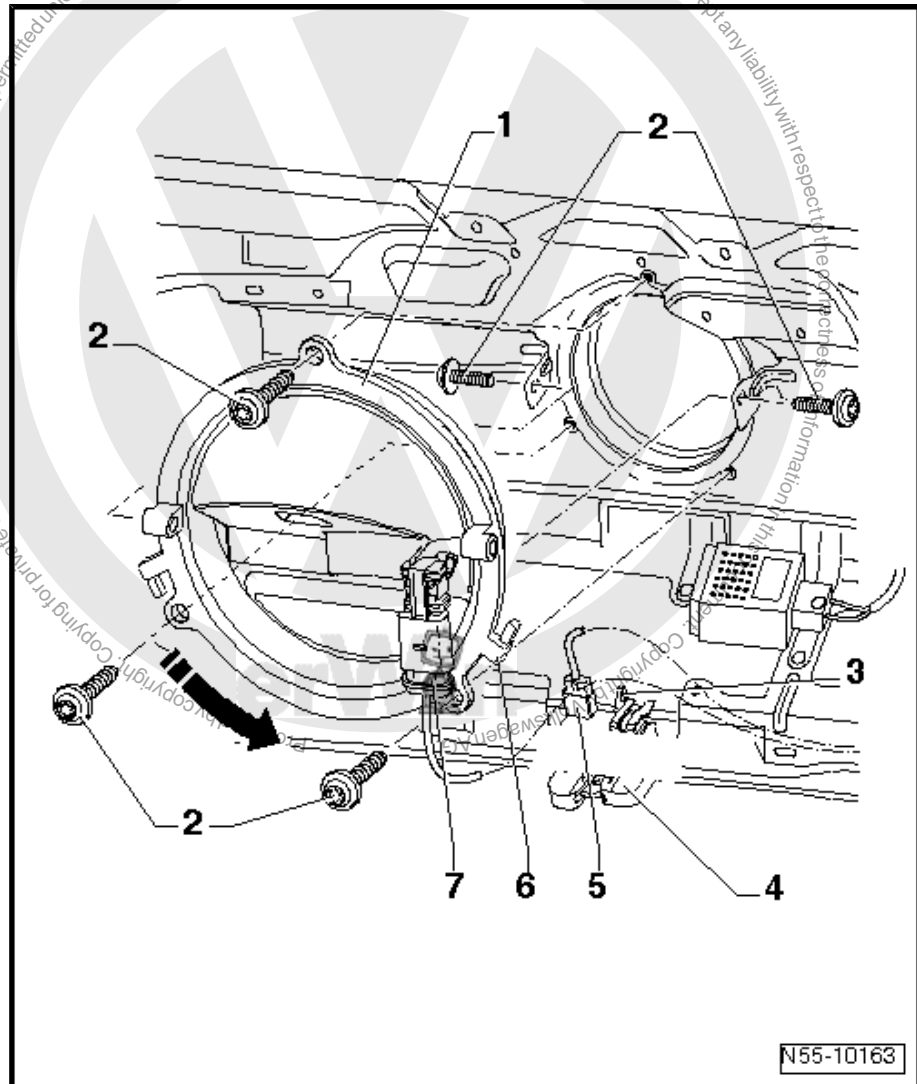

- Remove rear lid trim ⇒ General body repairs, interior; Rep. Gr. 70; ; Trims and insulation; Rear lid trim .
- Remove rear window wiper motor ⇒ Electrical system; Rep. Gr. 92 ; Window wiper and washer system; Rear window wiper system .
- Separate connector -7- from release element -1-.
- Remove bolts -2-.
- Loosen release element contrary to the -arrow- from the retaining brackets -6-
- Then remove release element -1-.

2.10.2 Installing

Installation is carried out in reverse order of removal.

- Specified torque for release element bolts: 4 Nm.
- Before closing rear lid, check function of lid release components.



2.11 Removing and installing lid lock



Note

If rear lid will not open, it can be opened by hand using the emergency release -1- on rear lid lock -2-. Emergency release can be found through an aperture in the rear lid trim

2.11.1 Removing

- Remove rear lid trim ⇒ General body repairs, interior; Rep. Gr. 70; ; Trims and insulation; Rear lid trim .
- Disconnect connector -4- from lid lock -2-.
- Remove bolts -3- and guide lid lock -2- downwards and out of lid.

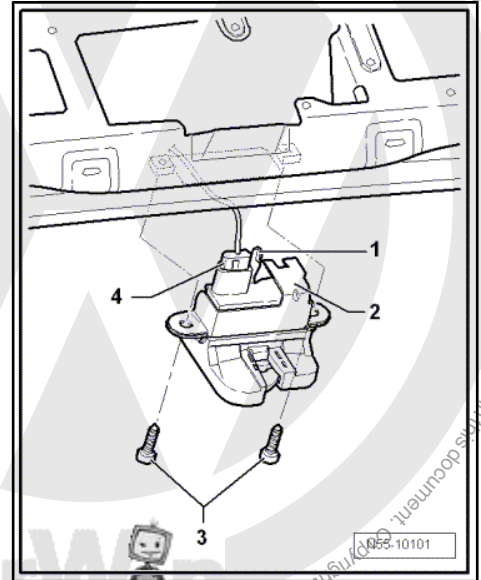

2.11.2 Installing

- Guide rear lid lock -2- into rear lid and tighten bolts -3-.
- Specified torque for bolts -3-: 23 Nm.
- Attach connector -4- for rear lid lock -2-.

Further installation is performed in the reverse order of removal.

- Before closing rear lid, check function of lid release components.

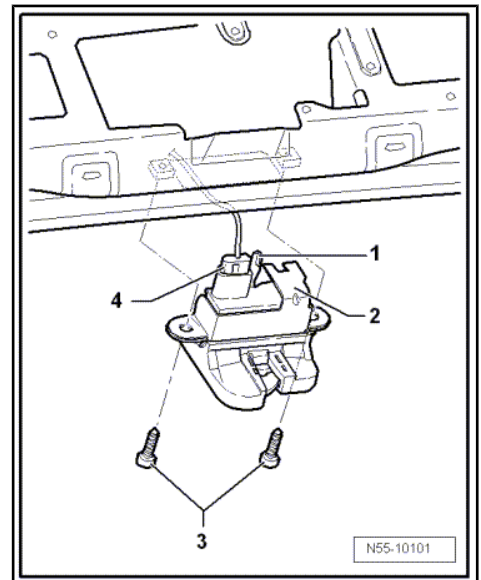

2.12 Rear lid seal

During production, a sealant is applied to the rear lid seals, the seal is then placed on the rear lid flange and rolled on.



Note

- ◆ *When seals are removed, the sealant will spread to the inside of the seal and the flanks will be bent out slightly. If the seal is then refitted, a leak-free tight seal is not guaranteed.*
- ◆ *Therefore each seal which is removed completely should be replaced by a so-called "tap-on" seal.*
- ◆ *If a seal has been partially removed, squeeze sides of seal together before installing.*

2.13 Removing and installing rear lid seal

2.13.1 Removing

- Pull rear lid seal -1- off body flange.

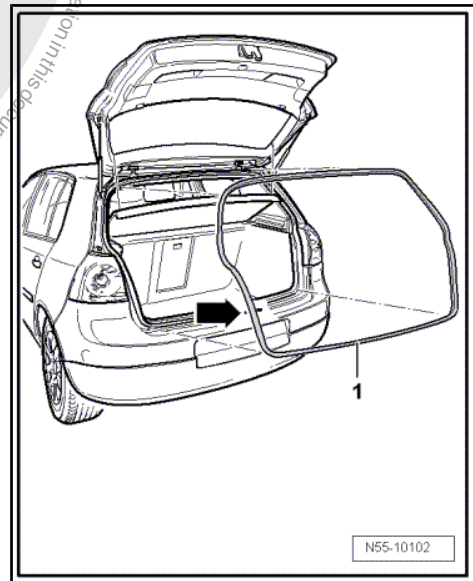

2.13.2 Installing

- Align rear lid seal -1- so that the vulcanised point -arrow- is located to the middle of the rear left light cluster.

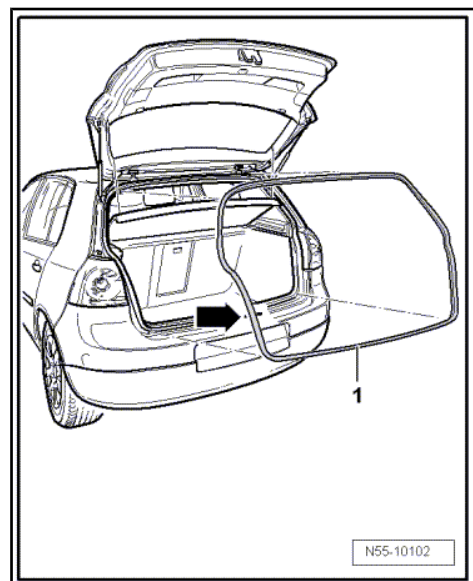



3 Tank flap unit

3.1 Tools

Special tools and workshop equipment required

- ◆ Socket -T 10010-

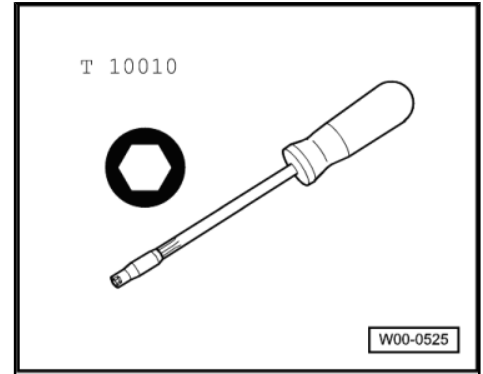

3.2 Assembly overview - tank flap unit

1 - Tank flap unit

- Removing ⇒ [page 42](#)

2 - Bolt

- 1.5 Nm

3 - Drain hose

4 - Assembly piece

5 - Release rod

6 - Securing bolt for actuator

- Qty. 2
- 1.5 Nm

7 - Fuel tank filler flap actuator (F219)

- Removing ⇒ [page 44](#)

8 - Seal

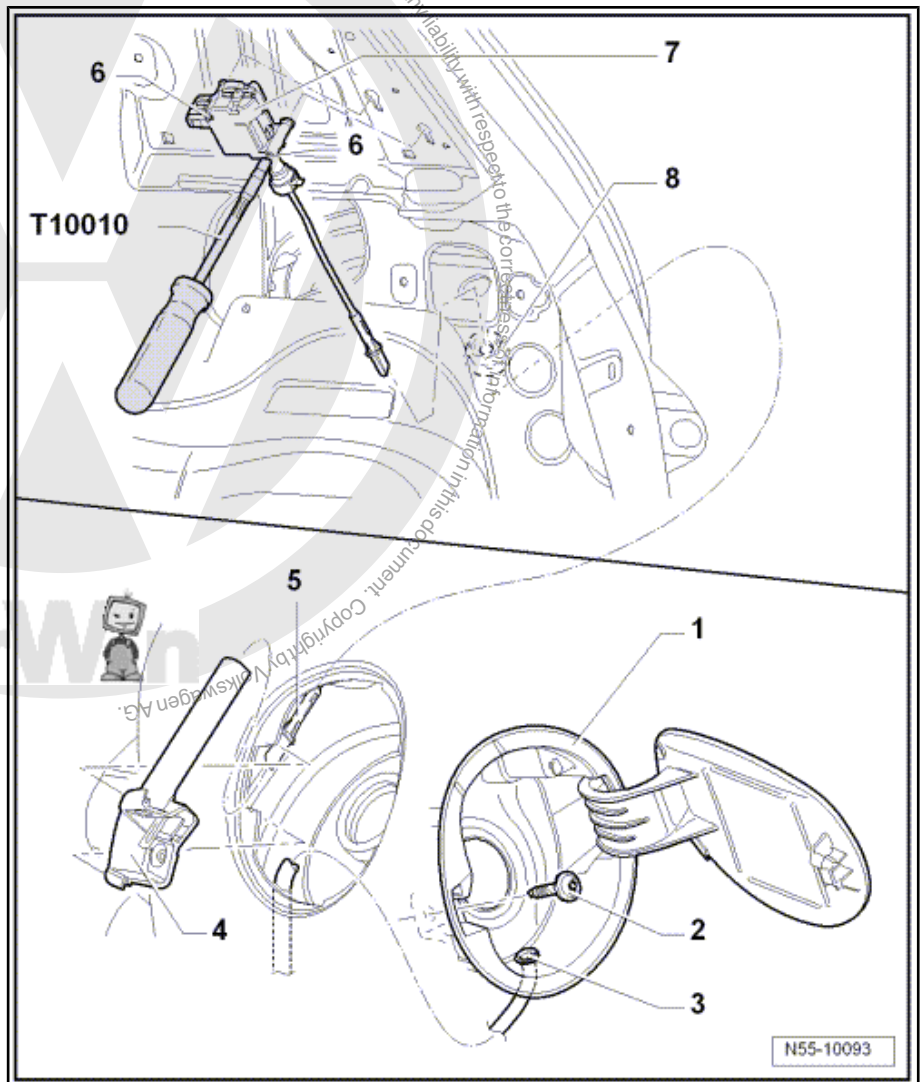



3.2.1 Removing tank flap unit



Note

If the fuel tank filler flap does not open, open by hand using the release rod -5-. The side trim must be removed to do this.

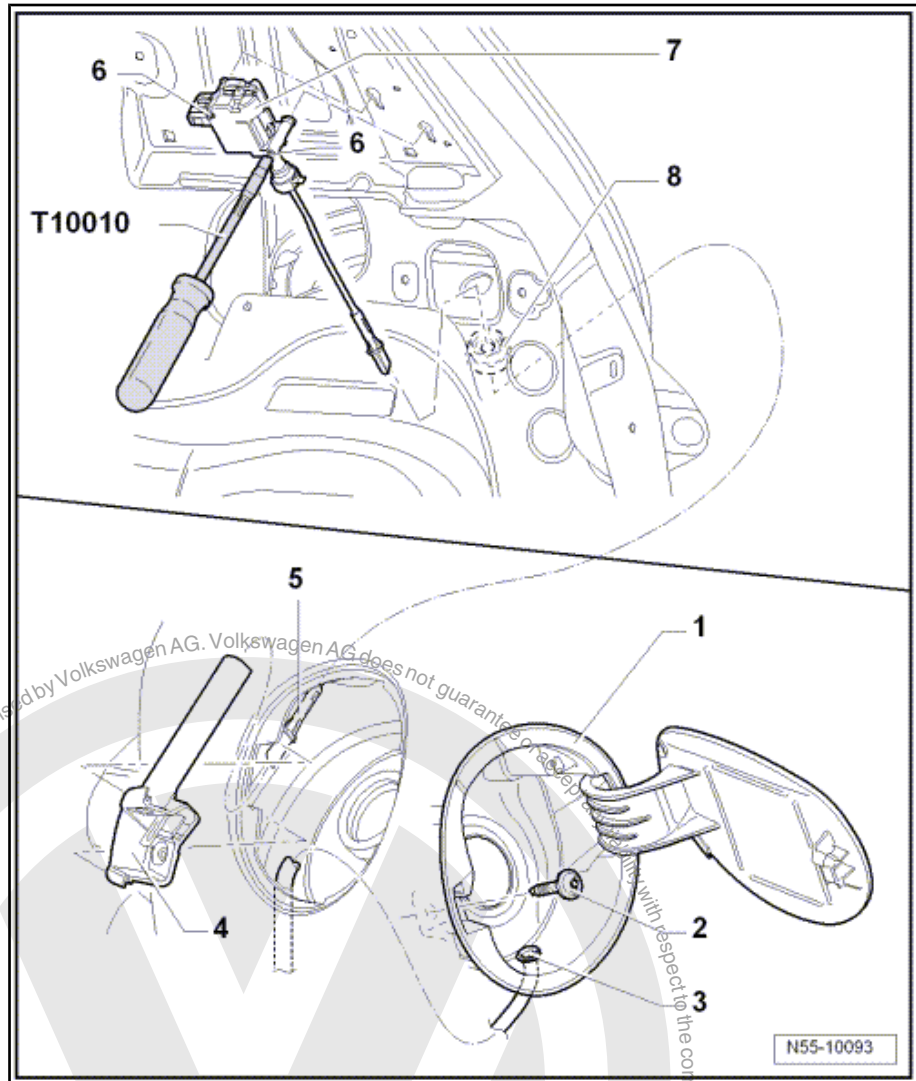

- Open fuel tank flap.
- Remove fuel filler cap.
- Remove bolt -2-.
- Pull rubber part off fuel tank filler neck.
- Pull fuel tank flap unit -1- with drain hose -3- to rear and swing fuel tank flap unit out of side panel.
- Unclip assembly part -4- out of side panel and pull assembly part off release rod -5-.



3.2.2 Installing tank flap unit

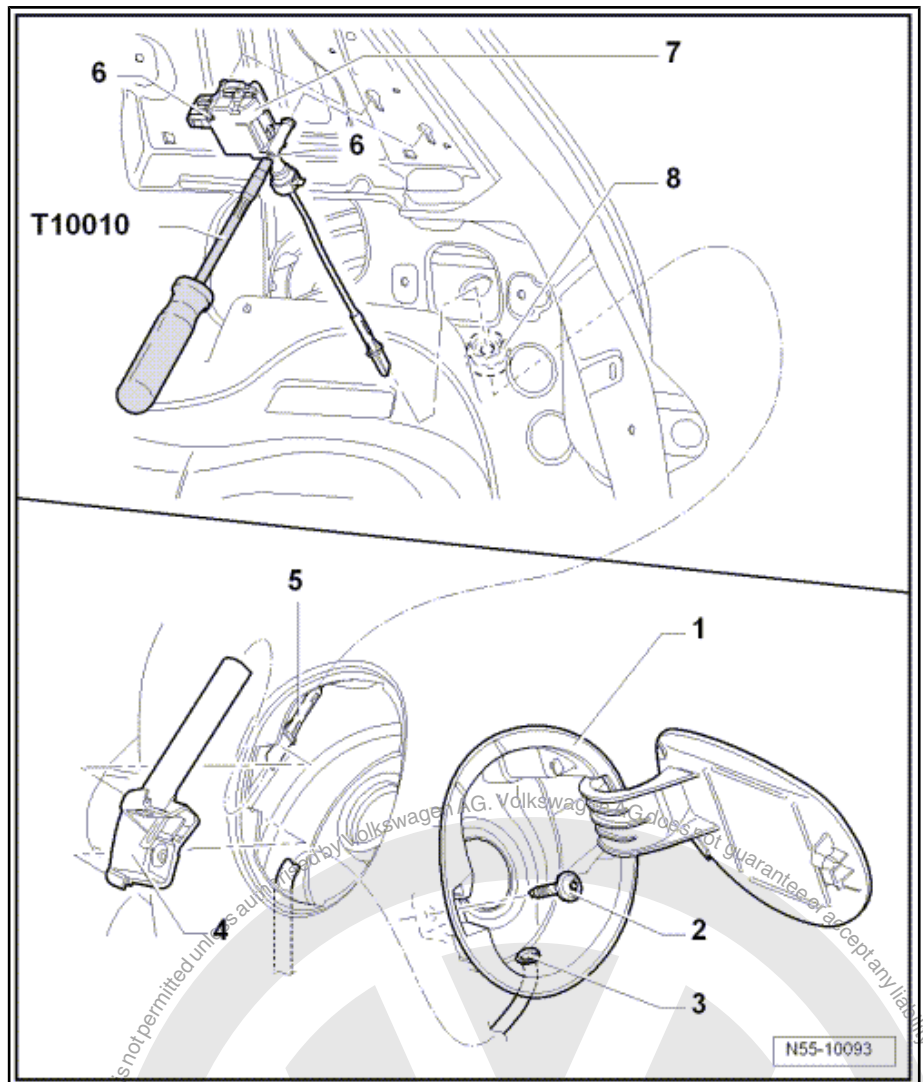

- The mounting part -4- has been pushed in.
- Pass drain hose -3- through the opening in tank flap unit and pull hose through as far as possible.
- Guide drain hose into side panel.
- With hinge side leading guide tank flap unit -1- into side panel.
- Then swivel tank flap unit completely into side panel, ensure that the locating hooks at top and bottom properly locate in side panel.
- Pull rubber part over filler neck and tighten bolt -2-.

Specified torque for bolt -2-: 1.5 Nm.



3.2.3 Removing actuator

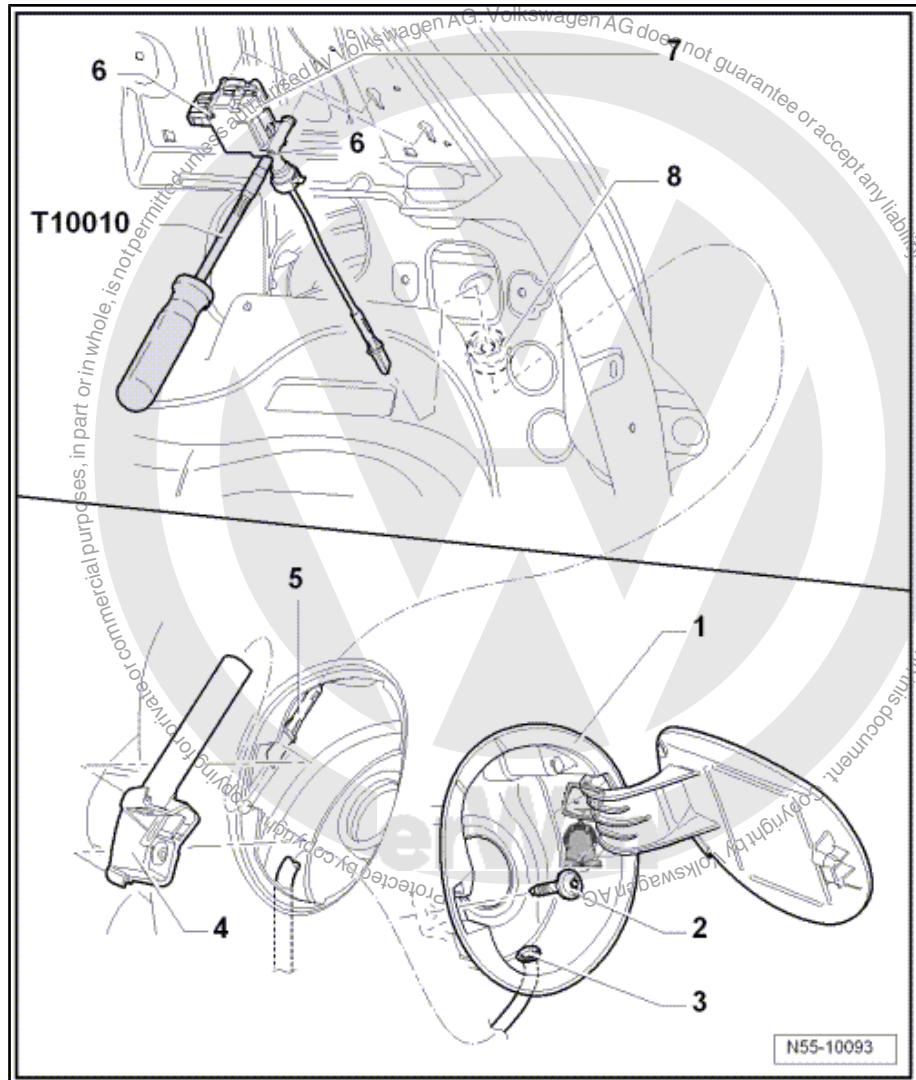

- Remove luggage compartment side panel trim ⇒ General body repairs, interior; Rep. Gr. 70 ; Trims, insulation; Luggage and load compartment trims .
- Disconnect connector on actuator -7-.
- Release actuator -7- using hexagon socket screwdriver -T 10010- .
- Pull actuator -7- together with release rod -5- out of seal -8-.

3.2.4 Installing actuator

Installation is carried out in reverse order of removal.



57 – Front doors, door components, central locking

1 Front door

1.1 Tools

Special tools and workshop equipment required

- ◆ Socket -T 10072-
- ◆ Assembly tool -T 10118-
- ◆ Door alignment tool -3320-
- ◆ Universal joint for 3320 -3320/1-
- ◆ Bit for 3320 -3320/2-
- ◆ Bit for 3320 -3320/3-
- ◆ Roller for fitting door insulation foil -3356-
- ◆ Torque wrench 5...50 Nm - V.A.G 1331-
- ◆ Setting gauge -3371-

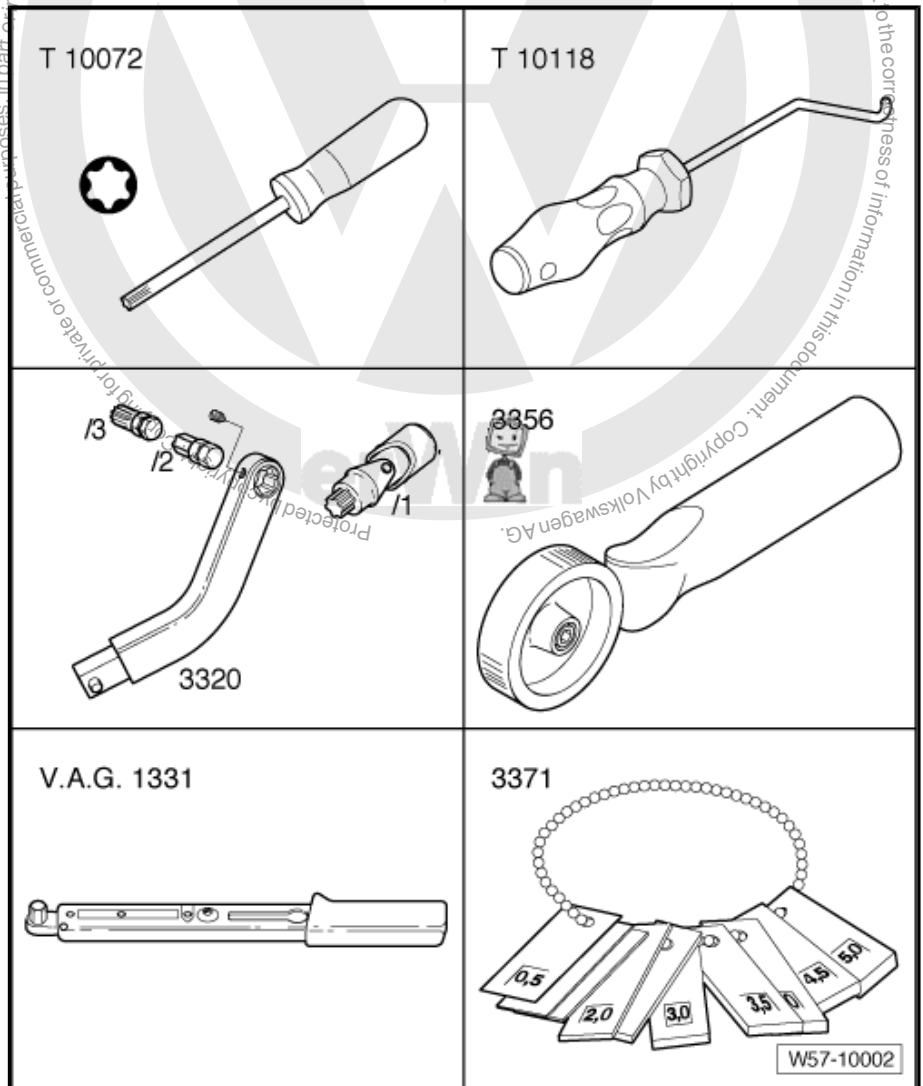



- ◆ Cartridge gun -V.A.G 1628-
- ◆ Cartridge heater -V.A.G 1939 A-
- ◆ Wedge -3409-
- ◆ Assembly tool set -T 10237-

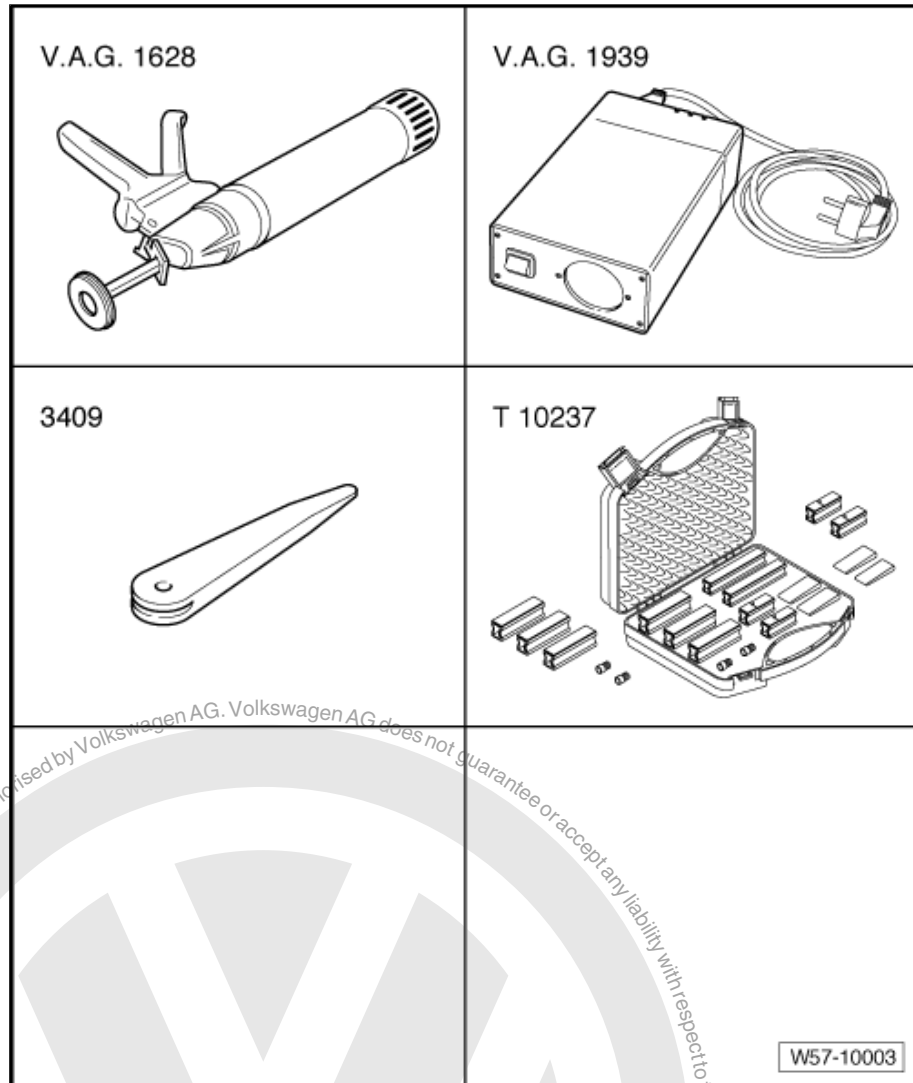

1.2 Materials

- ◆ 1K window adhesive DH 009 100 01^{2) 3)}
- ◆ Glass primer/paint primer D 009 200 02¹⁾
- ◆ Cleaning solution D 009 401 04¹⁾
- ◆ Primer applicator D 009 500 25¹⁾
- ◆ Door repair kit D 438 520 A2⁴⁾

1) Materials are stored in box D 004 700.

2) Observe minimum curing period ⇒ [page 64](#)

3) Heat, according to manufacturers instructions, using cartridge heater -V.A.G 1939-.

4) Folding cardboard carton with 10 sheets each with 15 adhesive strips.

1.3 Assembly overview - door assembly

A new door concept has been introduced with Golf 2004.

The door consists of a door inner part -6- and door outer panel -1-.



The parts are joined by the front -7- and rear -5- retaining rails.

The retaining rails are bolted to the door inner part and bonded to the door outer panel.

The door inner part -6- serves amongst other things as the previously known assembly carrier. Loudspeaker, window regulator, window regulator motor, wiring, window guides, exterior mirror and door lock are mounted on the door inner part.

The door outer panel -1- is additionally bolted to the lower edge of the door inner part. The window slot seals, insulation and door outer handle are mounted on the door outer panel.



Caution

Bolts of different types are used to secure door outer panel. If these are fitted in the wrong positions, the door outer skin will be damaged.

1 - Door outer panel

- Removing and installing
⇒ [page 94](#)

2 - Edge protection

- Between door outer skin and door inner panel

3 - Bolt

- Feature: bolt with pointed end and thin washer.
- Qty. 6 on lower edge
- Qty. 2 in area of top section of trim
- 10 Nm

4 - Rear retaining rail

- Adhesive:
DH 009 100 03

5 - Bolt

- Feature: bolt without pointed end but with thick washer.
- Qty. 10 for both retaining rails on 4 door models
- Qty. 11 for both retaining rails on 2 door models
- 14 Nm

6 - Door inner part

- Assembly overview
⇒ [page 65](#)

7 - Front retaining rail

- Adhesive:
DH 009 100 03

8 - Bolt

- Feature: bolt with pointed end and thick washer.
- Qty. 1 for front area of top section of trim

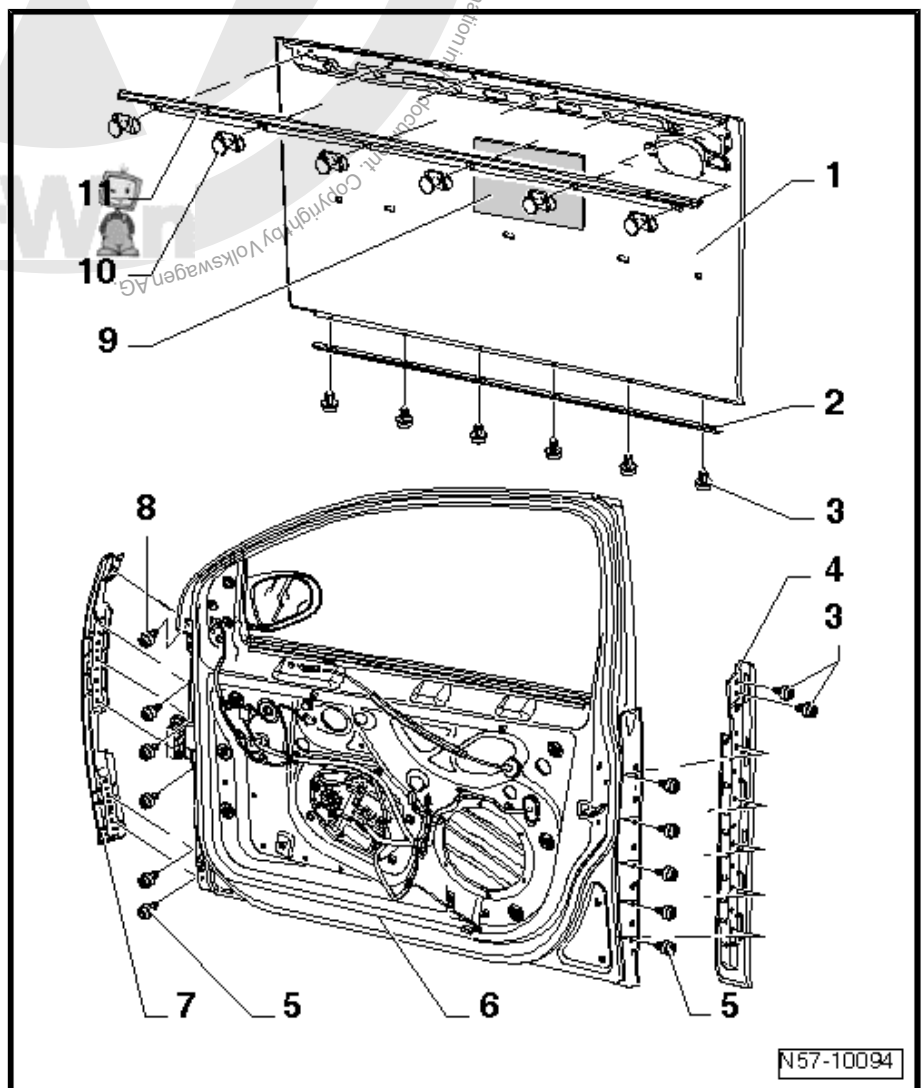



- 10 Nm

9 - Insulation

- Self-adhesive
- To bond, first heat the insulation and then press on firmly

10 - Clip

- Qty. 6

11 - Window slot seal

- Must be fitted before assembling door outer panel.

1.4 Assembly overview - door hinges



Caution

Bolt of eccentric pin -10- should not be loosened under any circumstances on vehicles up to 01.2004. It cannot be tightened again using normal workshop tools.



i Note

- ◆ The right side is shown. The left side is similar.
- ◆ The hinge bolts must always be renewed if loosened.
- ◆ Hinges are now one piece.
- ◆ The specified torque for the hinge bolts to the door (bolts -4, 6 and 14-) has been revised.

1 - Door

- Removing and installing
 ⇒ [page 50](#)
- Adjusting ⇒ [page 52](#)

2 - Guide bolt

- 10 Nm

3 - Door hinge with arrester

4 - Multi-point socket head bolt

- 50 Nm
- Bolts must always be replaced by new ones after being undone

5 - Multi-point socket head bolt

- Installed from inside the vehicle
- Remove lower A-pillar trim ⇒ General body repairs, interior; Rep. Gr. 70 ; Trims, insulation; Pillars and side trims
- 20 Nm + 1/4 turn further (90°).
- Bolts must always be replaced by new ones after being undone

6 - Multi-point socket head bolt

- 50 Nm
- Bolts must always be renewed after being loosened

7 - Multi-point socket head bolt

- 20 Nm + 1/4 turn further (90°).
- Bolts must always be replaced by new ones after being undone

8 - Guide bolts

- 10 Nm

9 - Adjustment ring

- Restricts the adjustment range for the eccentric pin

10 - Bolt

- For eccentric pin
- 28 Nm

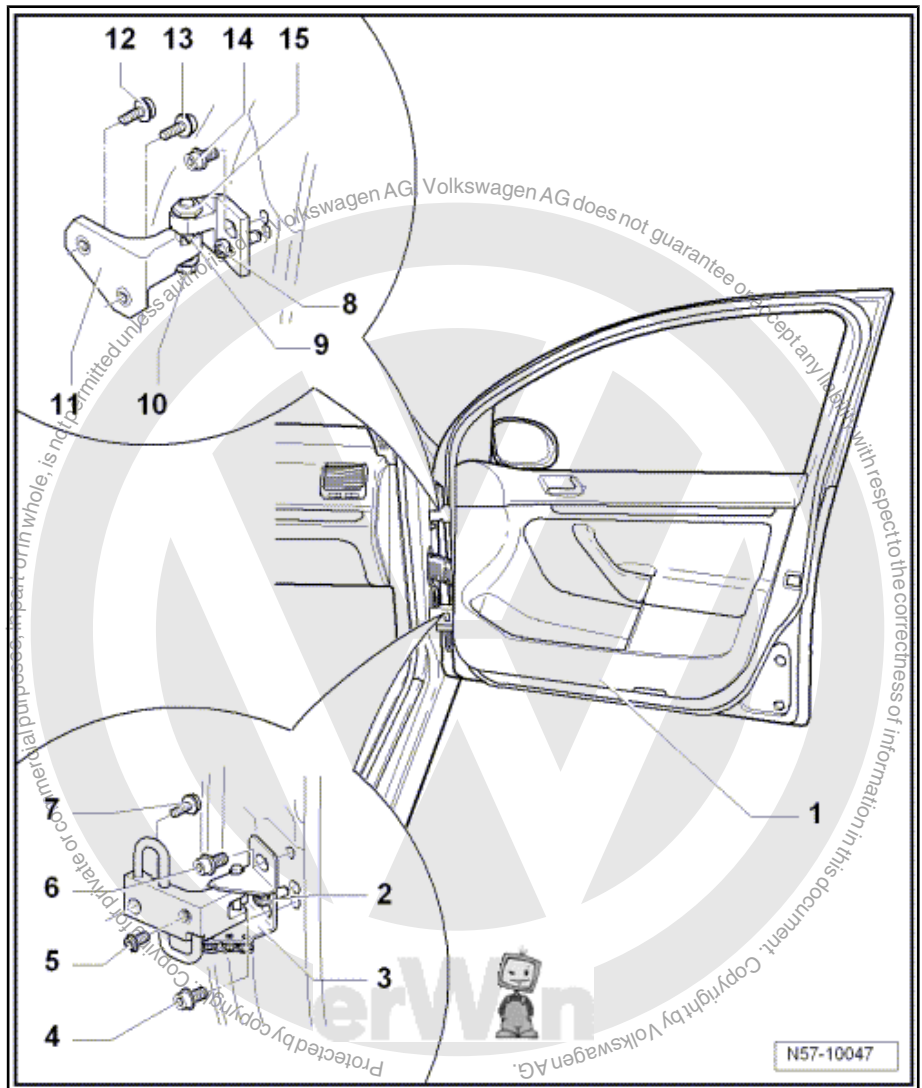



11 - Door hinge

- Door hinge no longer comprises of more than one part

12 - Multi-point socket head bolt

- 20 Nm + 1/4 turn further (90°).
- Bolts must always be renewed after being loosened

13 - Multi-point socket head bolt

- 20 Nm + 1/4 turn further (90°).
- Bolts must always be replaced by new ones after being undone

14 - Multi-point socket head bolt

- 50 Nm
- Bolts must always be replaced by new ones after being undone

15 - Eccentric pin

- Eccentric pin is used to adjust gap on vehicles as of 02.2004

1.5 Removing and installing door



Note

*The removal and installation sequence is only for the right door.
The removal and installation of the left door is similar.*





1.5.1 Removing

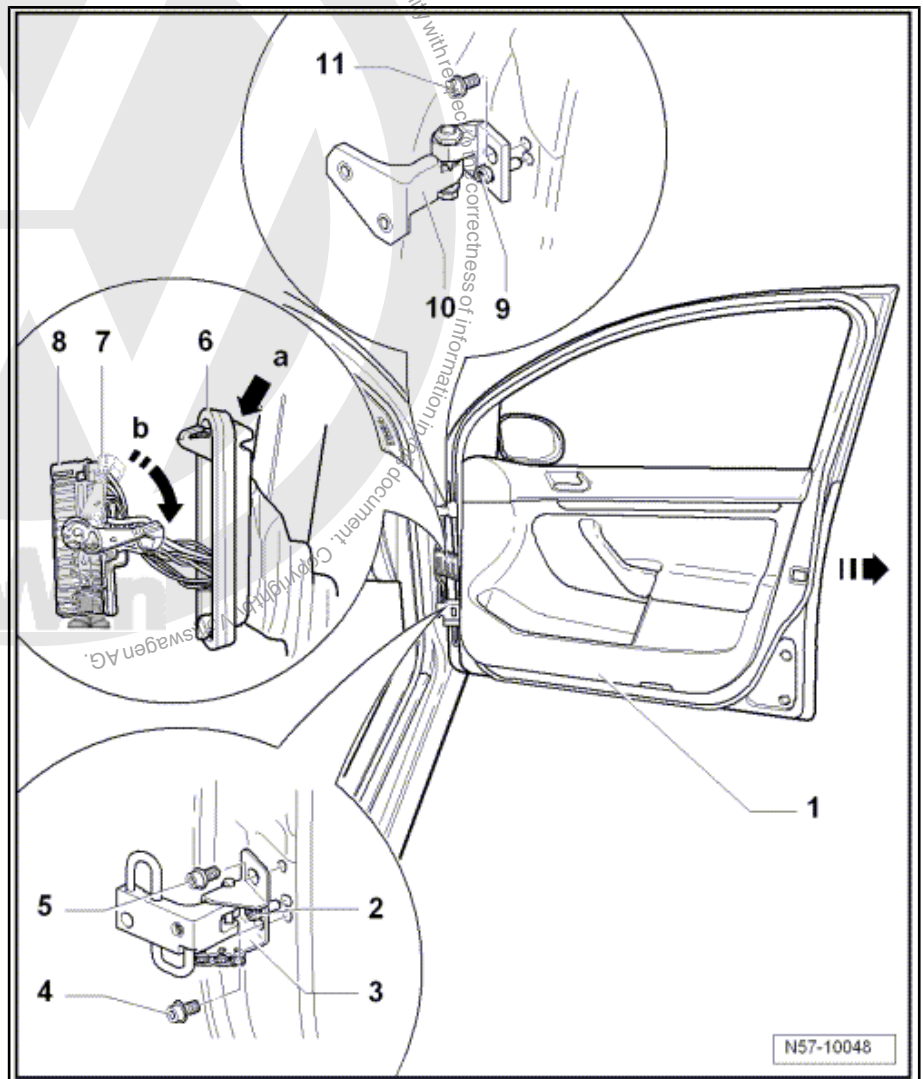

- Release bellows -6- by pressing the catch -arrow a- and pull bellows off A-pillar.
- Swing release lever -7- downwards -arrow b- and disconnect electrical connector -8- from coupling station.
- Remove bolts -4, 5 and 11- from hinge using special door alignment tool -3320- and bit -3320/3- .
- Pull door in -direction of arrow- off guide bolts -2 and 9-.

1.5.2 Installing

Installation is carried out in reverse order of removal.

- Specified torque, bolts -4, 5 and 11-: 50 Nm.
- Always renew bolts -4, 5 and 11-.
- Note front door gap dimensions ⇒ Body Repairs; Rep. Gr. 00 ; Technical data; Body gap dimensions .



1.6 Adjusting door



Note

- ◆ *The door is adjusted correctly if the gaps/shut lines are even all around, the door is not too deep or does not stand proud and all contours align when the door is closed.*
- ◆ *Vehicle must be standing on its wheels on flat level ground when adjustments are performed.*
- ◆ *If door outer panel has been removed, door inner part window frame must be adjusted to roof frame and B-pillar, or rear door.*

1.6.1 Adjusting door gaps

Special tools and workshop equipment required

- ◆ Box spanner 15 mm -T10344-

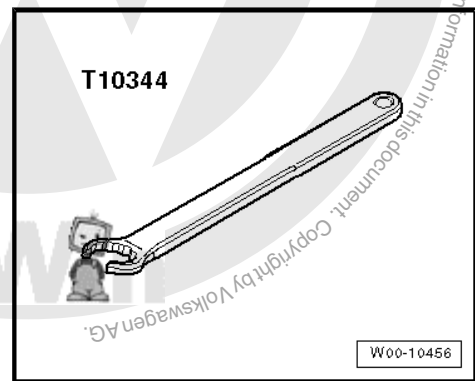

WARNING

Vehicles up to 01.2004, the bolt of the eccentric pin -10- must not be loosened and the eccentric pin -15- must not be used to adjust the door.

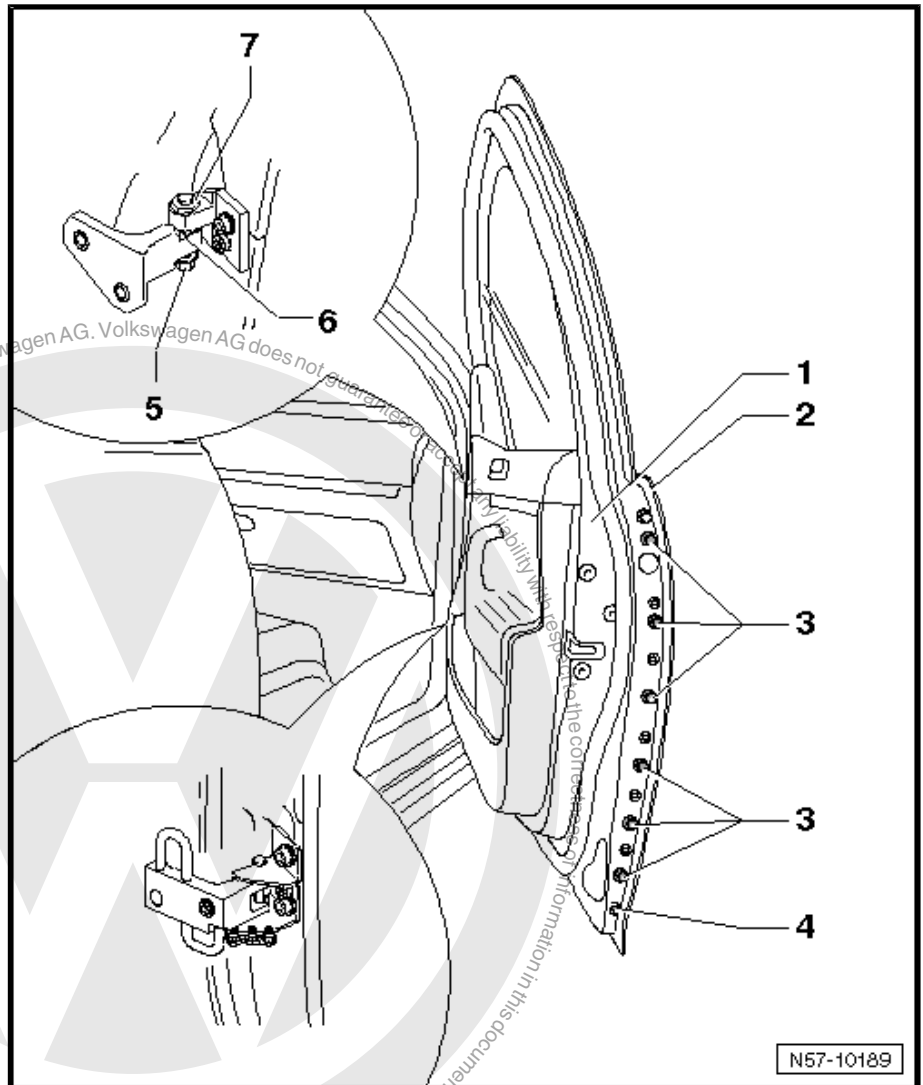

- Note front door gap dimensions → Body Repairs; Rep. Gr. 00; Technical data; Body gap dimensions .

Adjustments are carried out using eccentric pin -7-.

Other measures such as raising the door have no effect. Subsequent pressure from above will cause the door to sack again.

- Loosen bolt for eccentric pin -5-.
- Adjust eccentric pin -7- within adjustment range -6- using 15 mm ring spanner -T10344- .
- Tighten bolt -5- before checking setting.

The door outer panel -2- can be adjusted if the adjustment range is insufficient.

- Loosen bolts -3- and move door outer panel -2-.
- Retighten bolts -3- ⇒ [page 57](#) .



1.6.2 Adjusting door fittings for flushness

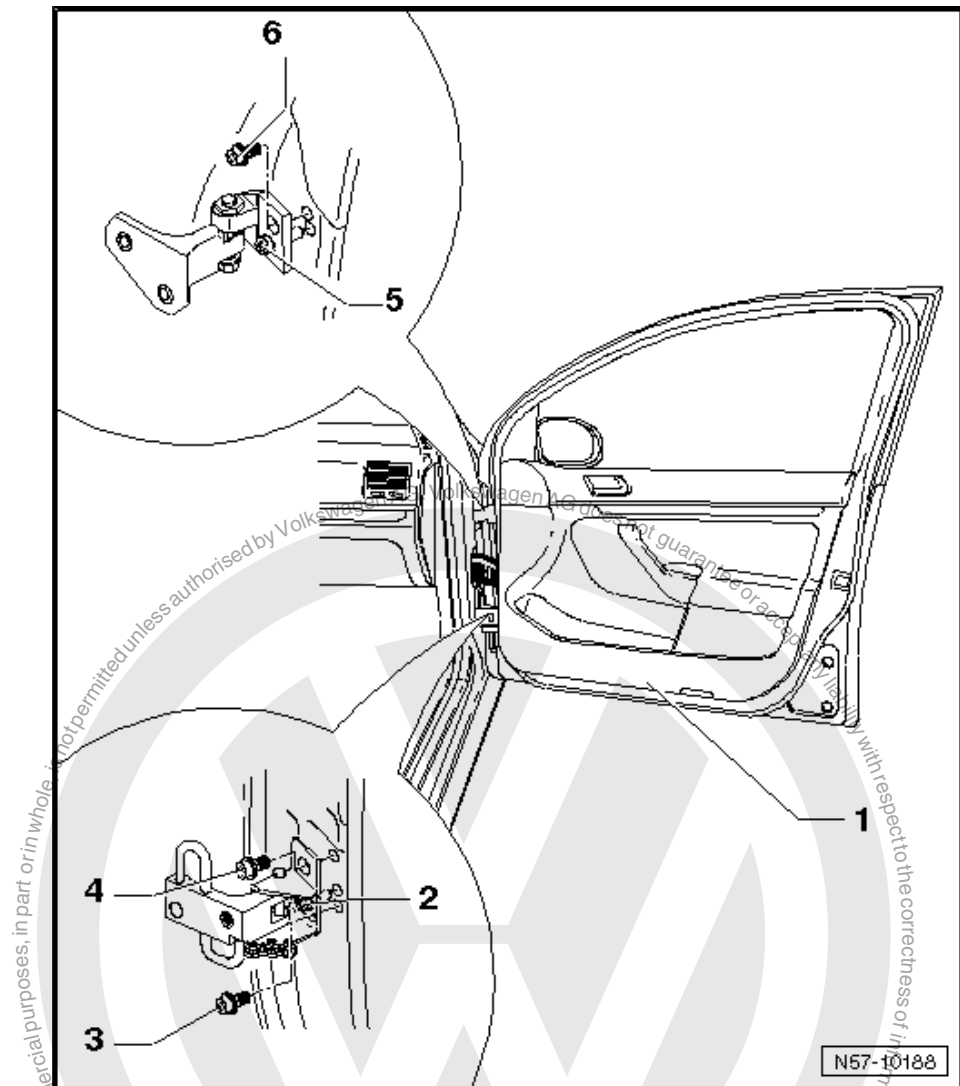

Use bolts -2, 3, 4, 5 and 6- on hinge to adjust correctly for flushness.

Use door alignment tool -3320- with bit -3320/3- .

- Adjusting upper area of door, loosen bolts -5 and 6-.
- Specified torque for bolt -5-: 10 Nm.
- Specified torque for bolt -6-: 50 Nm.
- To adjust lower area of door, loosen bolts -5 and 6-.
- Specified torque for bolt -2-: 10 Nm.
- Specified torque for bolts -3 and 4-: 50 Nm.

The bolts -3, 4 and 6- must always be renewed if loosened.

- Guide pin -4- may be ground down if necessary.



1.7 Removing and installing door outer panel

1.7.1 Removing

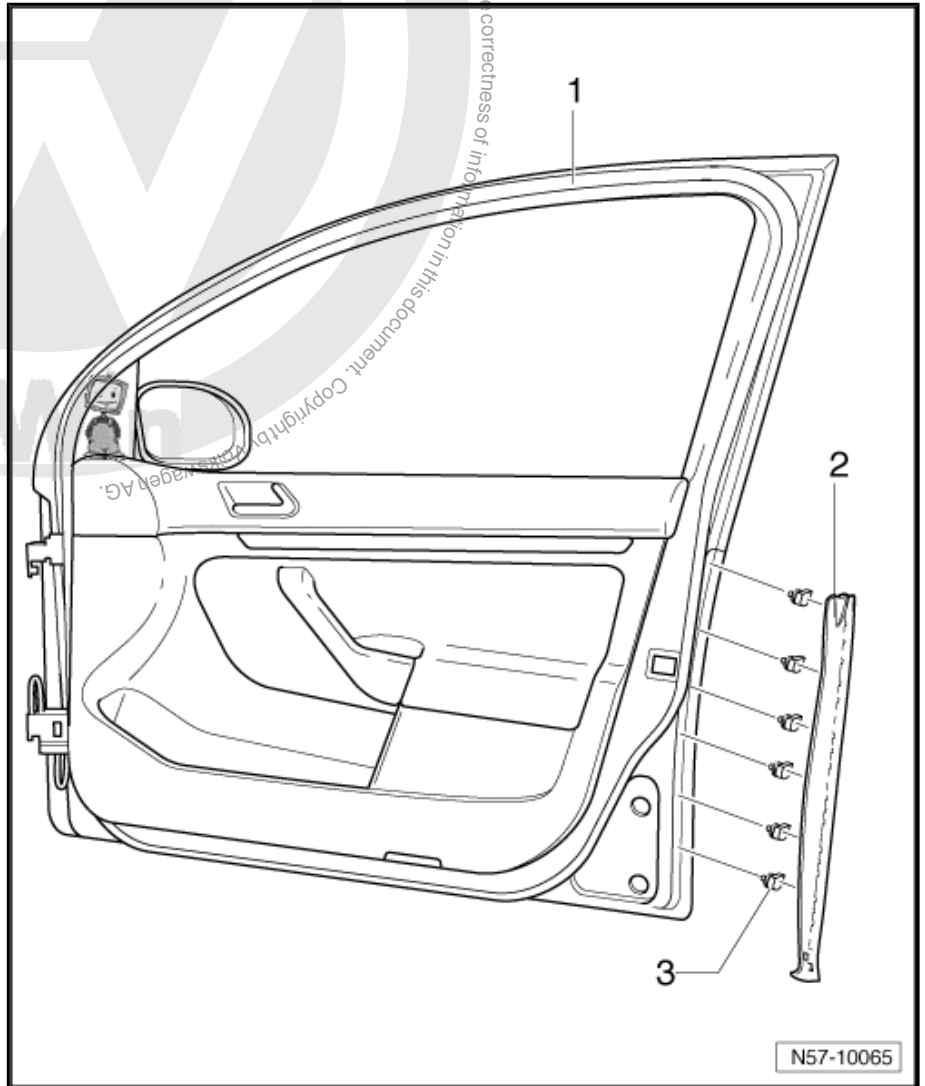

- Lever out clips-3- from the bottom starting on the door -1- and remove cover -2-.



- Remove lock cylinder => [page 67](#)
- Remove door handle => [page 68](#)
- Remove bolt -1- from mounting bracket -2- which is located behind door outer panel.

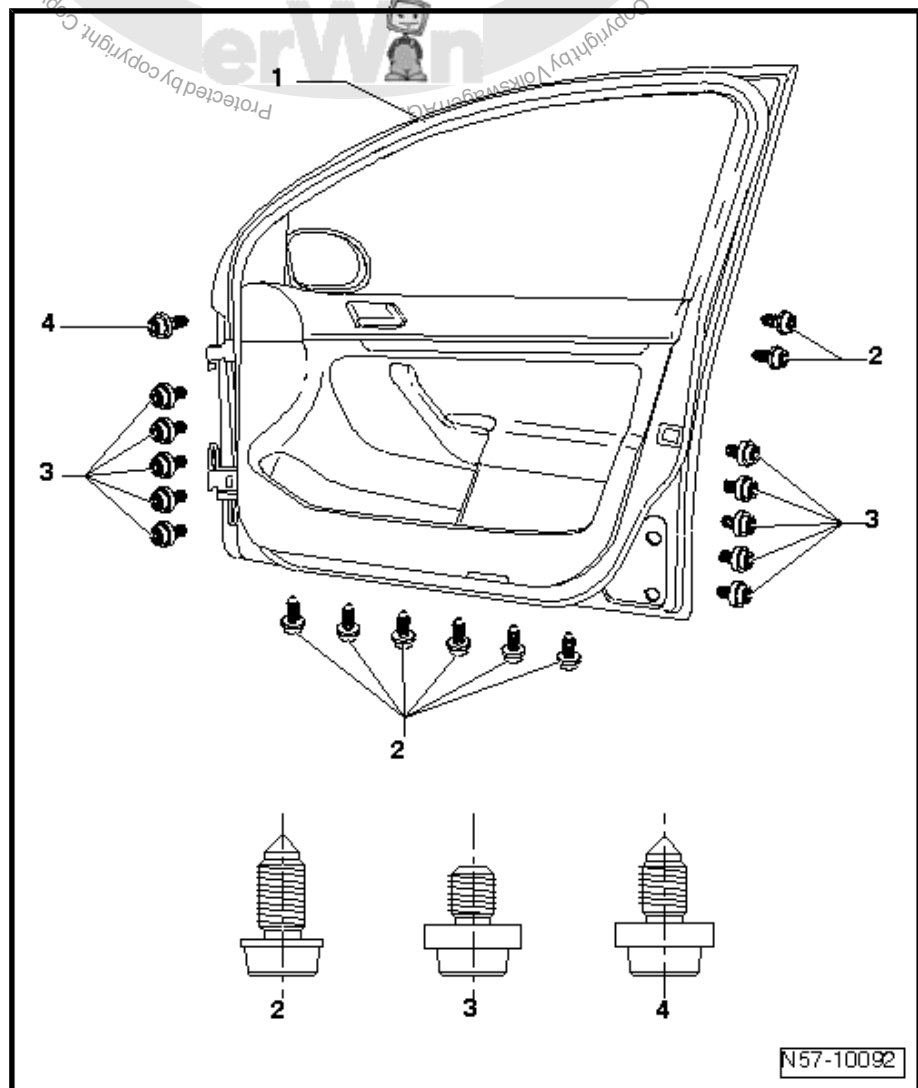
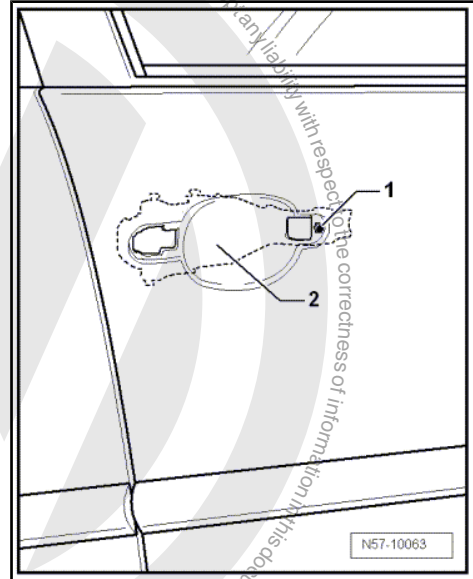

- Remove all bolts -2, 3 and 4-
- Carefully remove door outer panel.



1.7.2 Installing



Caution

Bolts of different types are used to secure door outer panel. If these are fitted in the wrong positions, the door outer panel will be damaged.

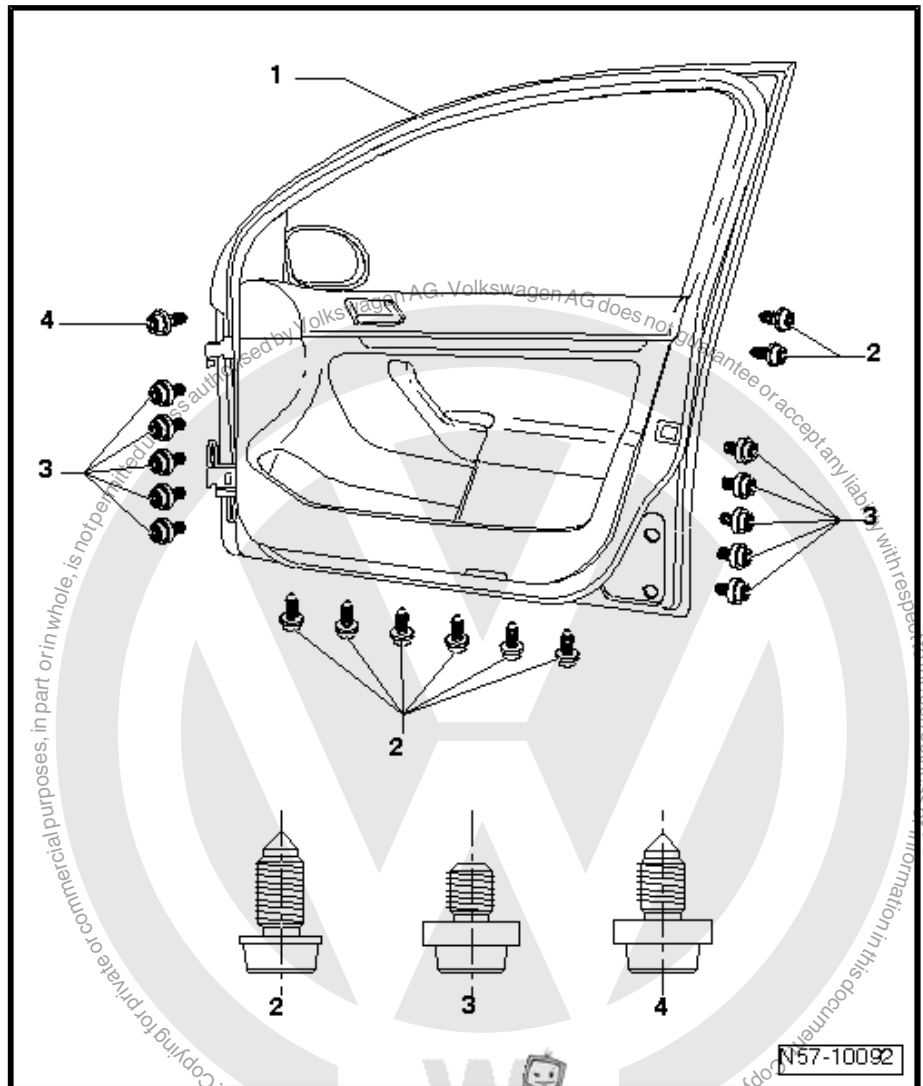

- Carefully fit door outer panel.
- Insert all bolts -2, 3 and 4-.
 - Observe correct usage for the different types of bolts.
 - ◆ Feature for bolt -2-: bolt with pointed end and thin washer.
 - ◆ Feature for bolt -3-: bolt without pointed end but with thick washer.
 - ◆ Feature for bolt -4-: bolt with pointed end and thick washer.
- Check whether the securing strut guide pins are located in the appropriate guide holes in door inner part. Then first tighten all bolts -2, 3 and 4-.



- Observe correct specified torque for the different types of bolts.

Specified torque for bolt -2-: 10 Nm.

Specified torque for bolt -3-: 14 Nm.

Specified torque for bolt -4-: 10 Nm.

Further installation is performed in the reverse order of removal.

1.8 Installing new outer panel for door



Caution

Bolts of different types are used to secure door outer panel. If these are fitted in the wrong positions, the door outer skin will be damaged.



Note

Observe section, installation notes for bonding-in a new door outer panel ⇒ [page 63](#)

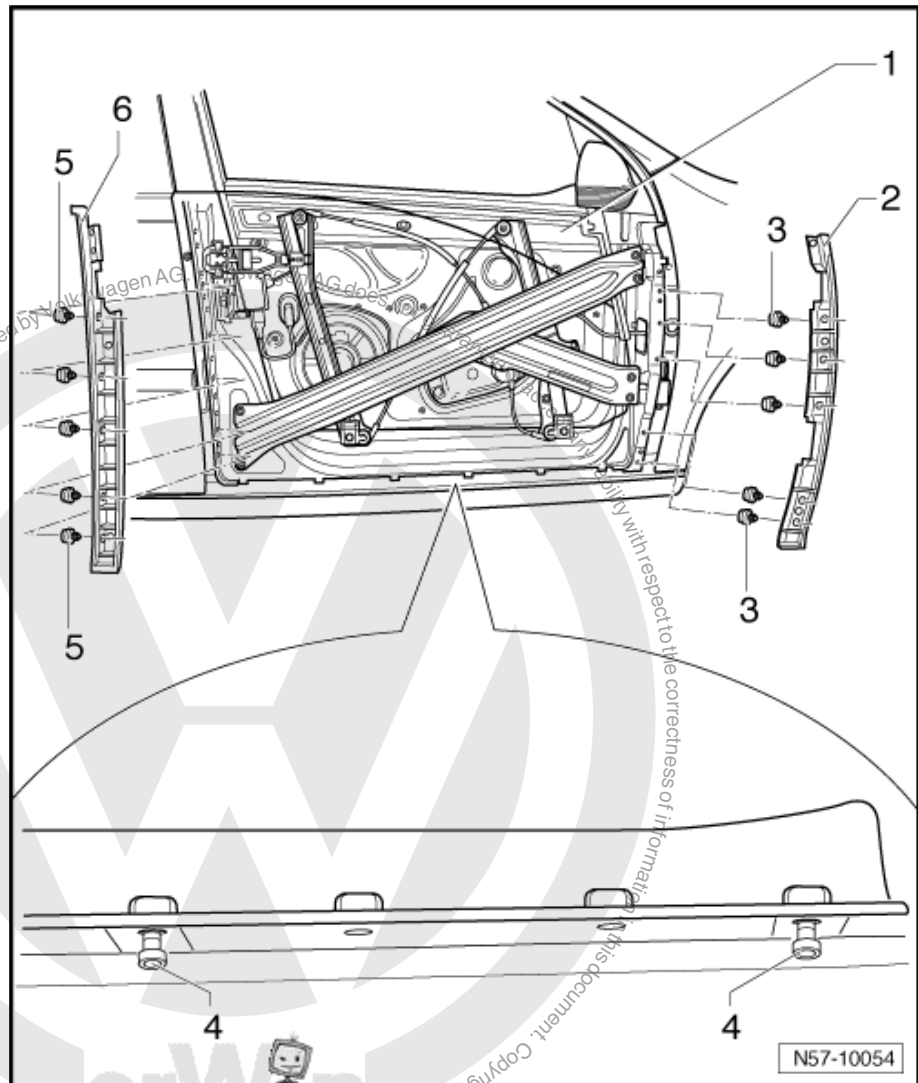



- The old (damaged) door outer panel with retaining rails is removed ⇒ [page 55](#)
- Install front -2- and rear -6- retaining rails to door inner part.
 For this use “bolt without point with thick washer”.

Specified torque for bolts -3- and -5-: 10 Nm.

- Fit two guide bolts in lower edge of door inner part.

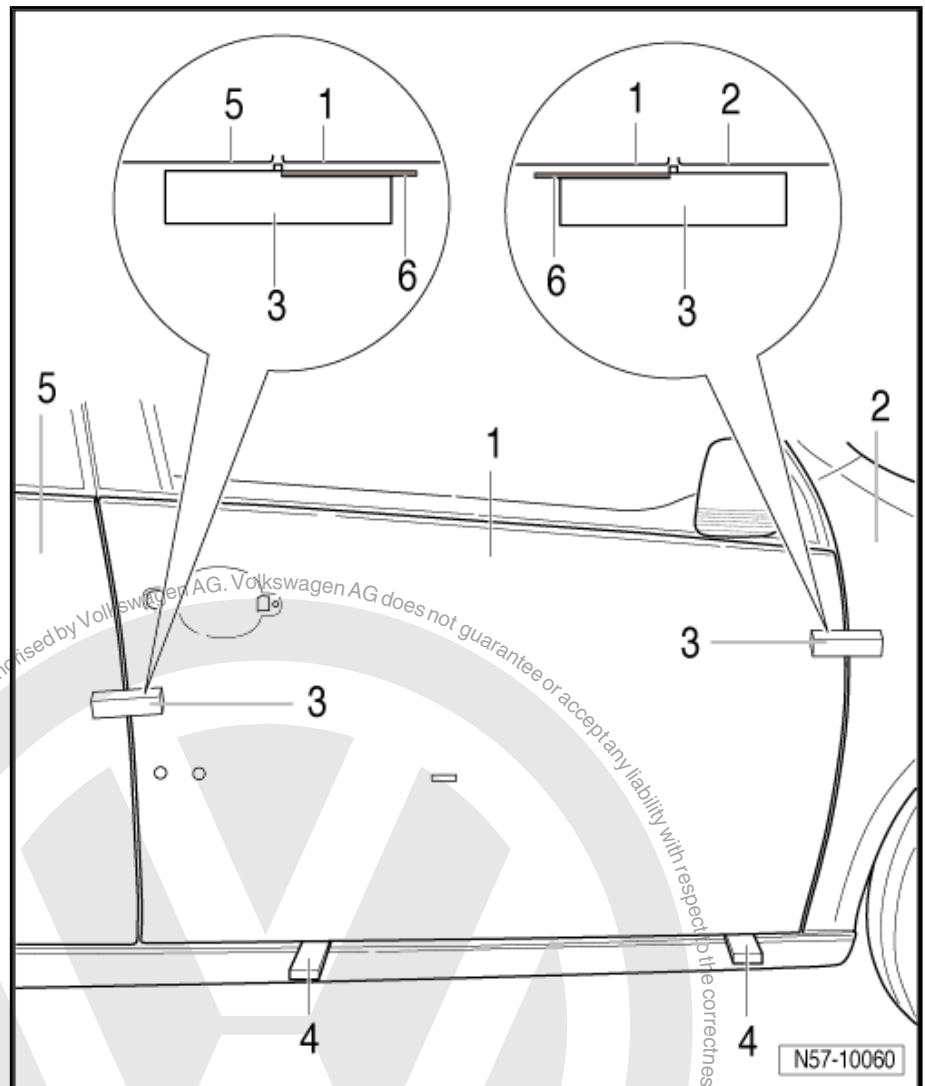

The painted door outer panel is first offered up without bonding agent.

Assembly block from assembly tool set -T 10237- is required to offer up the door outer panel. A strip of “Tesa Power Strips large” -6- is applied on the lower side. The pin has the minimum dimension for the gap width. The non bonded surface is brought into position with the adjacent component.

- Bond assembly block -3- on door outer panel.
- Guide door outer panel -1- over guide bolts in lower edge of door inner part.
- Adjust gap to side member and door outer panel height using wedges -4- from assembly tool set -T 10237- .



- Place door outer panel with assembly blocks on surrounding components -2 and 5-.
- Check gap dimension using setting gauge -3371- → Body Repairs; Rep. Gr. 00 ; Technical data; Body gap dimensions .
- If gap dimension cannot be adjusted further, door inner part must be adjusted ⇒ [page 52](#)
- Remove door outer panel again.

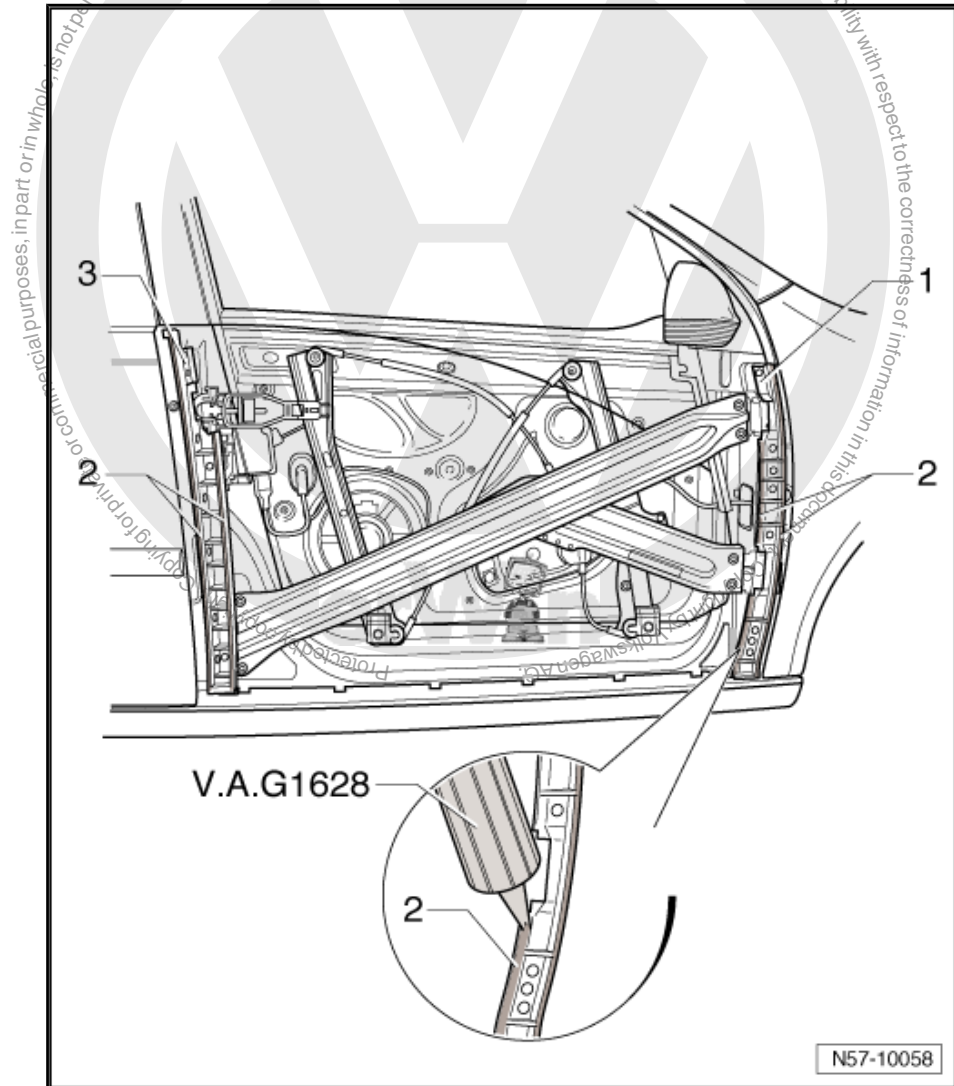

- Apply a bead of adhesive material -2- using cartridge gun - V.A.G 1628- to front -1- and rear -3- retaining rails.

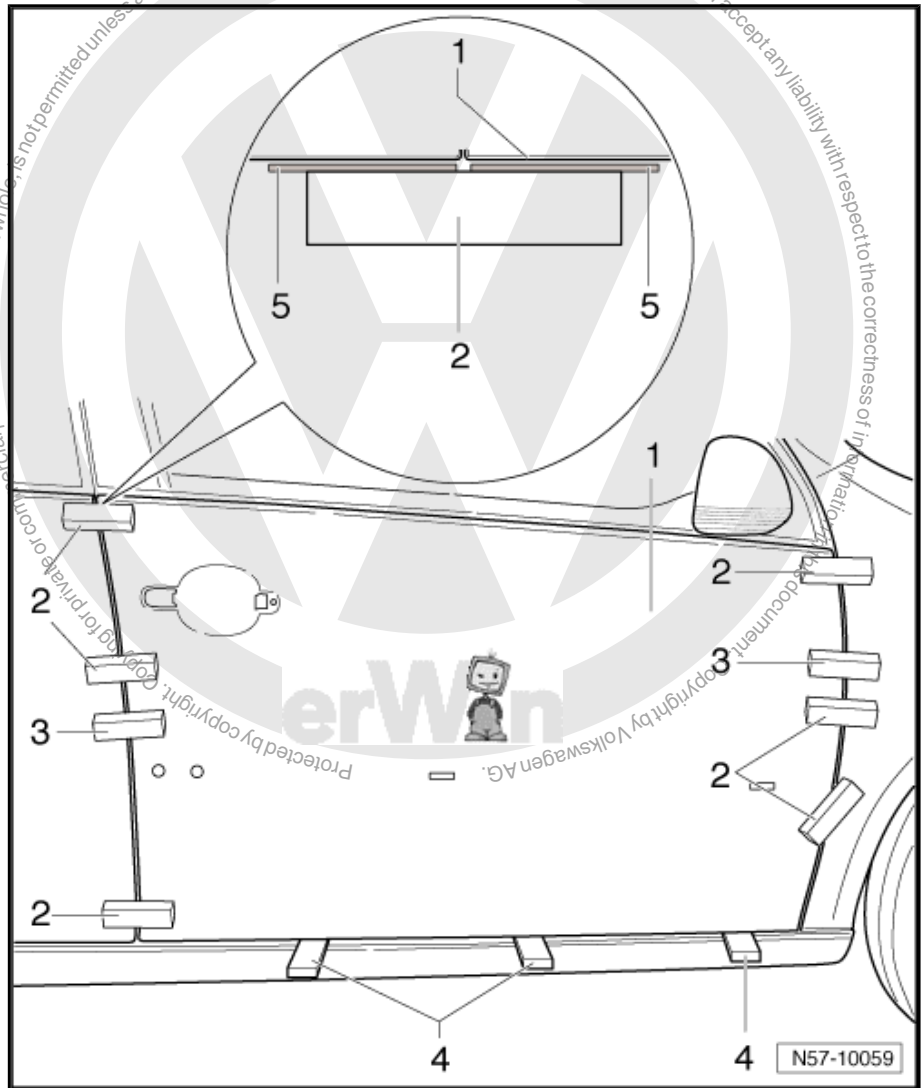

Use fixing block from assembly tool set T10237 to insert door outer panel. Two strips of "Tesa Power Strips large" -5- are bonded to the contact surfaces.

- Guide door outer panel -1- over guide bolts in lower edge of door inner part.
- Bring door outer panel with assembly blocks -3- into contact with surrounding components.
- Adjust the gap to side member and adjust door outer panel height using wedges -4- from assembly tool set.
- Check gap dimensions using setting gauge -3371- ⇒ Body Repairs; Rep. Gr. 00 ; Technical data; Body gap dimensions .
- Bond short fixing block -2- evenly on the replacement door and the adjacent components.

i Note

A curing period of 180 minutes must be observed before performing further work on the door which has been bonded.

- Further installation is performed in the reverse order of removal ⇒ [page 57](#) .



1.9 Removing and installing retaining rail on door outer panel

1.9.1 Removing retaining rail



Caution

The following work steps are to be carried out with great care. As door outer skin is to be reused, dents and scratches must be avoided.

When cutting through the adhesive bead, always hold the retaining rail and door outer skin together as shown in the illustration. If this is not done, the door outer skin will come away from the retaining rail, thus rendering it useless.



Note

The following work steps should be carried out with the aid of an assistant.

Door outer panel with retaining rail is removed ⇒ [page 55](#)

- Place door outer panel -1- on firm surface and protect door outer panel against scratches.
- Fit reel device -2- in place.
- Secure cord -5- on reel device and counterhold -4-.
- Hold retaining rail and outer skin together securely when cutting through adhesive bead.
- Cut through adhesive bead of retaining rail -3- and door outer panel -1- with cord up to just over half way.

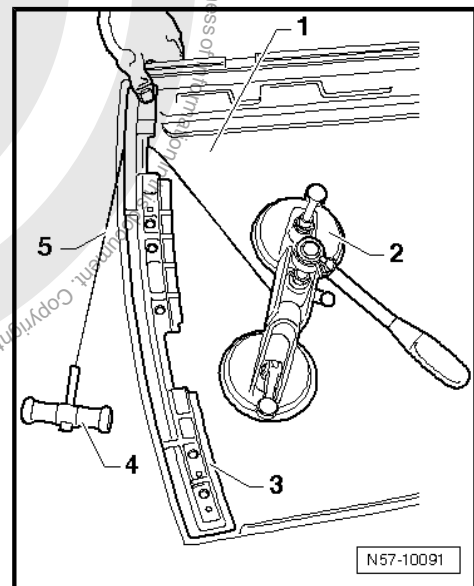

- Once adhesive bead has been cut through to just over half way in step one, turn reel device -2- around and insert cord -5- in side still bonded.
- Hold retaining rail -3- and outer skin -1- together securely when cutting through adhesive bead further.
- Cut through second half of adhesive bead.

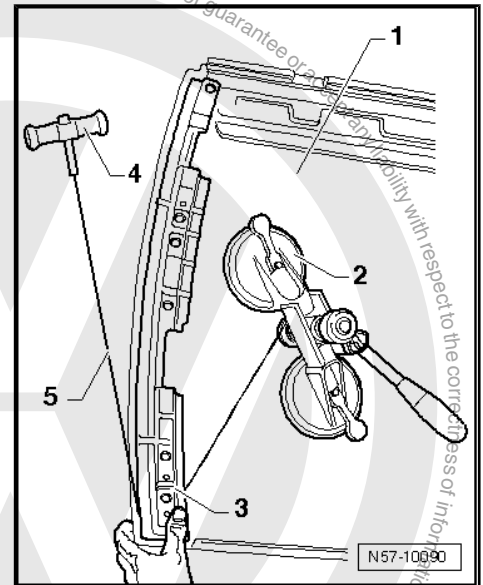

1.9.2 Installing retaining rail

- Cut away remainder of adhesive bead to a minimum on outer panel with the greatest of care, ensuring that no damage is caused to the paintwork.
- Remainder of work procedure is described in chapter entitled "Installing new door outer panel" ⇒ [page 58](#)

Note

Observe also "instructions for bonding in new door outer panel" when installing a new retaining rail.

- In place of removed retaining rail, install a new retaining rail on the door inner panel.
- Apply adhesive to new retaining rail.
- Tighten screws to secure door panel on lower edge and on retaining rail still in place.
- Secure door outer panel on new retaining rail with fixing blocks.

1.10 Installation instructions for bonding in new door outer panel

Note

- ◆ If both door outer panels on one side have to be renewed, the sequence must be observed. The rear door outer panel is aligned and bonded in first, followed immediately by the front door outer panel. The long fixing blocks must be bonded in from the rear door outer panel to the front door outer panel.
- ◆ If door outer panel CDP coating is damaged on inside in bonding area, or if this area has been painted, this area must be primed with glass/paint primer D 009 200 02.
- ◆ The 1K window adhesive DH 009 100 must be heated in cartridge heater -V.A.G 1939 A- for 20 minutes.



- Clean contact surfaces on retaining rails thoroughly using cleaning solution D 009 401 04.
- Apply adhesive material to appropriate surfaces at right angles to retaining rail using cartridge gun -V.A.G 1628- .



WARNING

Door outer panel must be installed within 10 minutes, or adhesive properties of adhesive will be impaired.

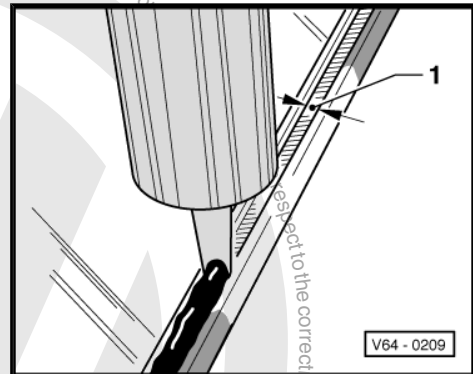

- ◆ With assistance of both assembly blocks, place door outer panel on retaining rails, align with wedges and setting gauge -3371- and press contact surfaces of assembly blocks onto surrounding components.
- ◆ Secure door with fixing blocks during curing time.
- ◆ After installation door outer panel must align with other components and gap dimension must be even.
- ◆ If adhesive bead is too thick and adhesive exudes between retaining rail and door outer panel, excess adhesive must be removed.

1.11 Minimum curing period



WARNING

Special standards must be adhered to when replacing bonded door outer panels. One of these standards is, for example, that a freshly bonded door outer panel must comply with the safety requirements, even in an accident, following the minimum specified curing period.

For 1-pack adhesive DH 009 100, the minimum curing time for the door outer panel is 180 minutes.

Minimum curing time means the time from bonding-in the door outer panel to the time the vehicle is brought into use or further work is carried out. During this time, the vehicle must stand on a level surface at room temperature (at least 15 °C).



WARNING

Vehicle is safe to use only after the minimum curing period is completed.

1.12 Cleaning off excess adhesive sealing material

- It is recommended to use cleaning solution D 002 000 10 as a cleaner. Observe the appropriate safety precautions when performing this work.



Caution

When cleaning vehicle, the door outer panel just bonded-in must not be moved.



- First clean painted surface as much as possible using a dry cloth. Remove remaining adhesive with adhesive remover D 002 000 10.
- Cleaning plastic trim: allow adhesive sealant to cure (approx. one hour) and then peel off.

1.13 Assembly overview - door inner part



Note

The right side is shown. The left side is similar.

- 1 - Door inner part
- 2 - Window slot seal
- 3 - Loudspeaker
- 4 - Window regulator motor
 - Removing ⇒ [page 199](#)
- 5 - Insulation
 - Qty. 4
 - 20 mm x 40 mm commercially available textile adhesive tape

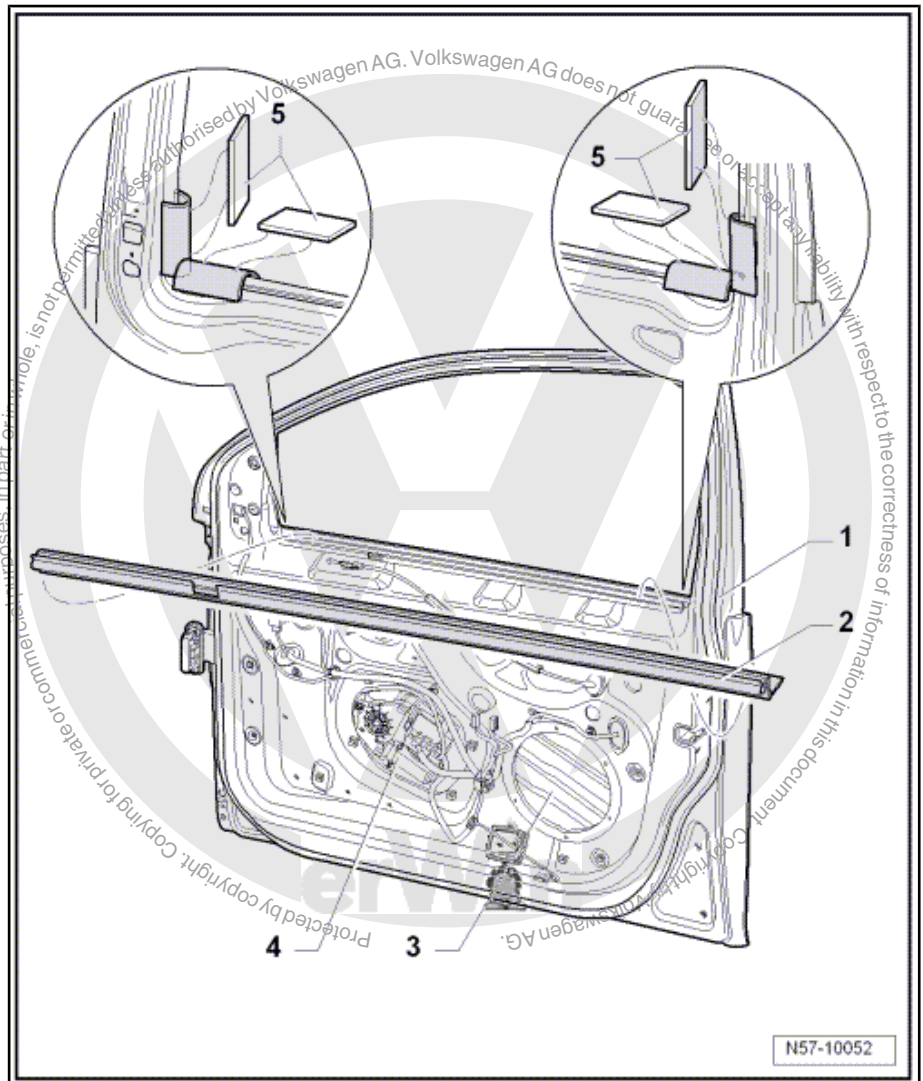



1.14 Assembly overview - door handle and door lock



Note

Only the left side is shown. The procedure for the right side is similar.

1 - Door lock

- Removing and installing
⇒ [page 72](#)

2 - Cable

- To release lock from
outer door handle

3 - Bolt

- To secure lock on door
inner part
- 18 Nm
- Qty. 2

4 - Bearing plate

- Removing and installing
⇒ [page 70](#)

5 - Bolt

- For lock cylinder

6 - Locking screw

- Not fitted on all models
- This bolt is installed to
provide additional se-
curity for the bearing
plate

7 - Base

8 - Lock cylinder housing

- Only on driver side
- Installed on the passen-
ger side is just a housing
- Removing and installing
⇒ [page 67](#)

9 - Cover

- For lock cylinder housing
- Secured to lock cylinder housing
with three locking lugs

10 - Key

- Changing battery ⇒ [page 82](#)
- Adapting new or additional key to remote control and immobiliser ⇒ [page 81](#)

11 - Door handle with base

- Removing and installing ⇒ [page 68](#)

12 - Base

- Part of door handle

13 - Torx screw

- Socket -T 10072-

14 - Spreader rivet

- Not installed on Golf

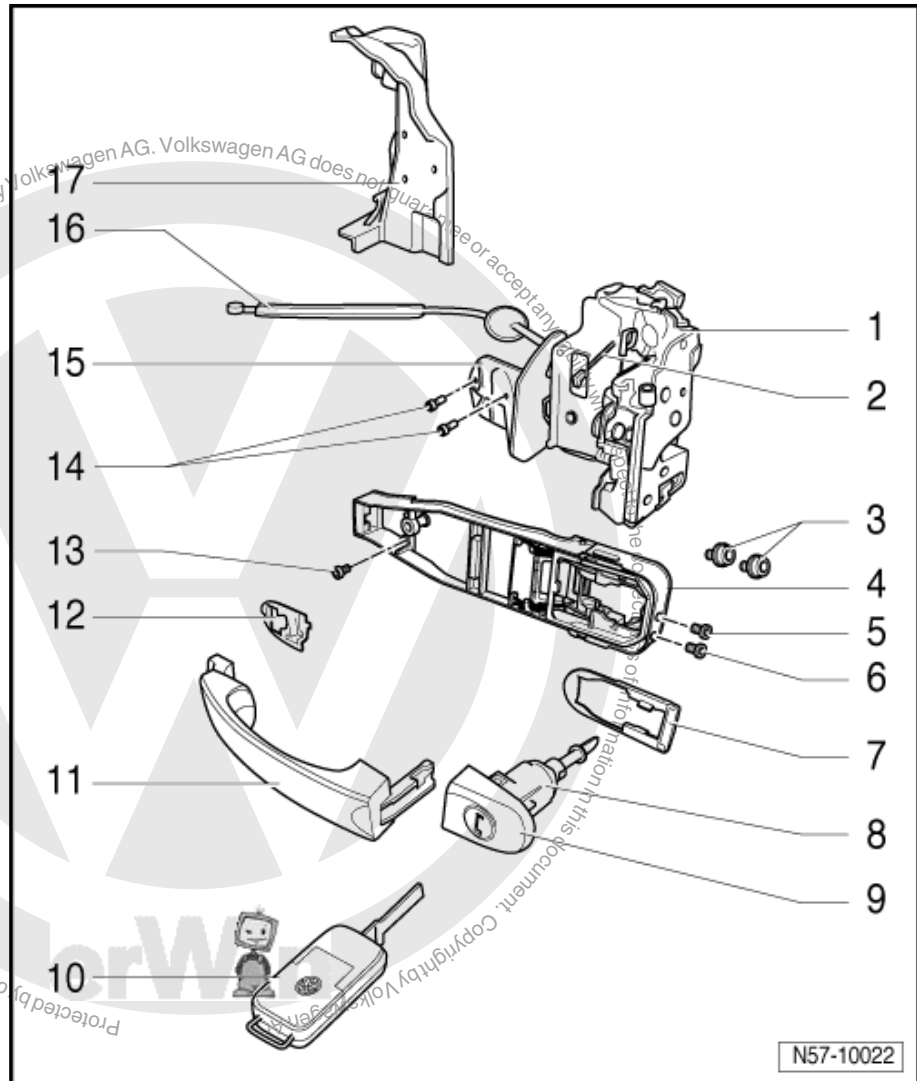



15 - Retaining bracket

- Not installed on Golf

16 - Cable

- To release lock from inner door handle

17 - Cover

- Not supplied as part of door lock
- Secured to door lock with three locking lugs

1.15 Removing and installing housing



Note

The removal and installation sequence is only for the right housing. The removal and installation of the right lock cylinder is similar.

1.15.1 Removing

- Lever out caps in front of bolts -1-.
- Pull door handle -2- in -direction of arrow- and unscrew bolt -1- using socket wrench -T 10072- until housing -3- can be pulled out.

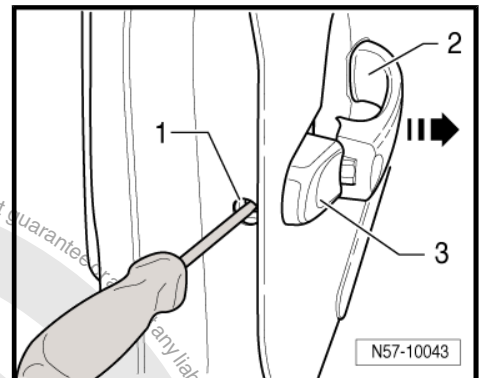

1.15.2 Installing

- Fit housing -3- in door handle mounting plate at right angles -arrow-.

Door handle -2- must rest only lightly against door panel.

- Now tighten bolt -1- in bearing plate using socket -T 10072- .

The door handle -2- locates in the housing -3- with a well audible click.

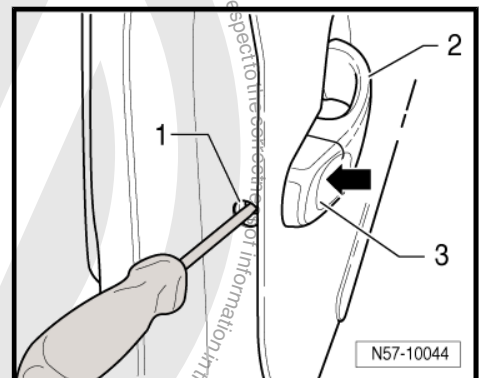

Note

During installation, housing must be pressed against door panel. Door handle rests only lightly against door panel.

Further installation is performed in the reverse order of removal.

- Then always check function while door is still open, as an incorrectly fitted and adjusted Bowden cable cannot open the door.



1.16 Removing and installing door handle



Note

The removal and installation sequence is only for the right door handle. The removal and installation of the left door handle is similar.

1.16.1 Removing

- Removing housing ⇒ [page 67](#) .
- Lever clip -2- out of door handle -1-.
- Swivel door handle -1- out of door -arrow-.

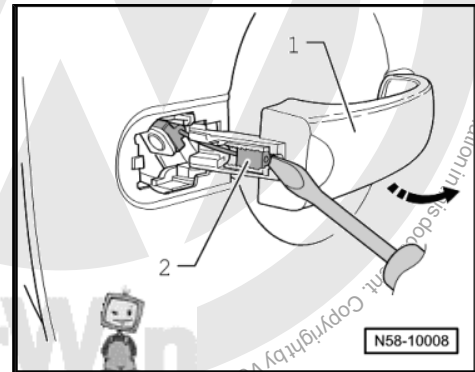



1.16.2 Installing

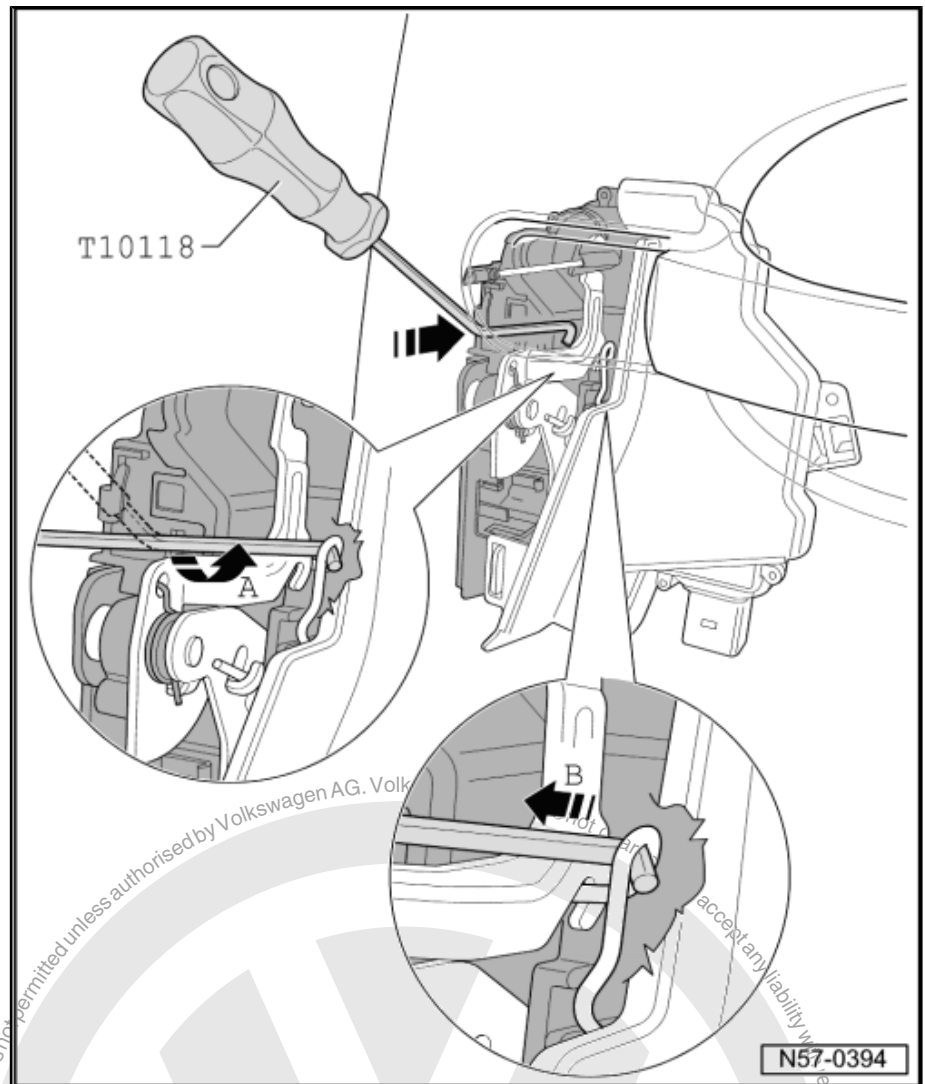

- Guide assembly tool -T 10118- into door through opening in door inner panel.
- Use a hand torch to illuminate inside of door for improved visibility.
- Hook assembly tool -T 10118- in spring -arrow A-.
- Hook spring into door lock by pulling assembly tool -T 10118- -arrow B-.

The release lever is now secured.

Note

Hooking the spring into the operating lever secures the lock. This prevents incorrect attachment of the Bowden cable to the door handle later.



- Swivel door handle -1- into door.
- Pull clip -2- in the panel opening and engage clip in door handle -1- -arrow-.



Note

- ◆ *Door handle -1- must be pressed against door panel when assembling.*
- ◆ *Clip -2- must engage in door handle -1- with a clearly audible click.*

Install housing ⇒ [page 67](#) .

- Then always check function while door is still open, as an incorrectly fitted and adjusted Bowden cable cannot open the door.

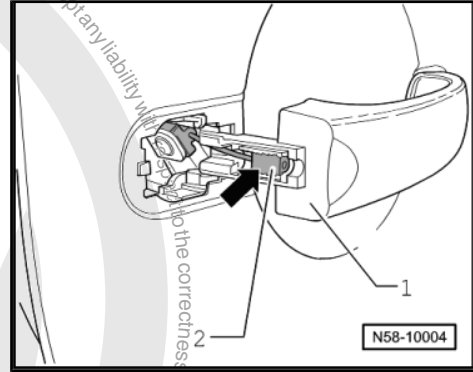

1.17 Removing and installing mounting plate



Note

Removal and installation are described only for the right bearing bracket. The removal and installation of left mounting plate is similar.



1.17.1 Removing

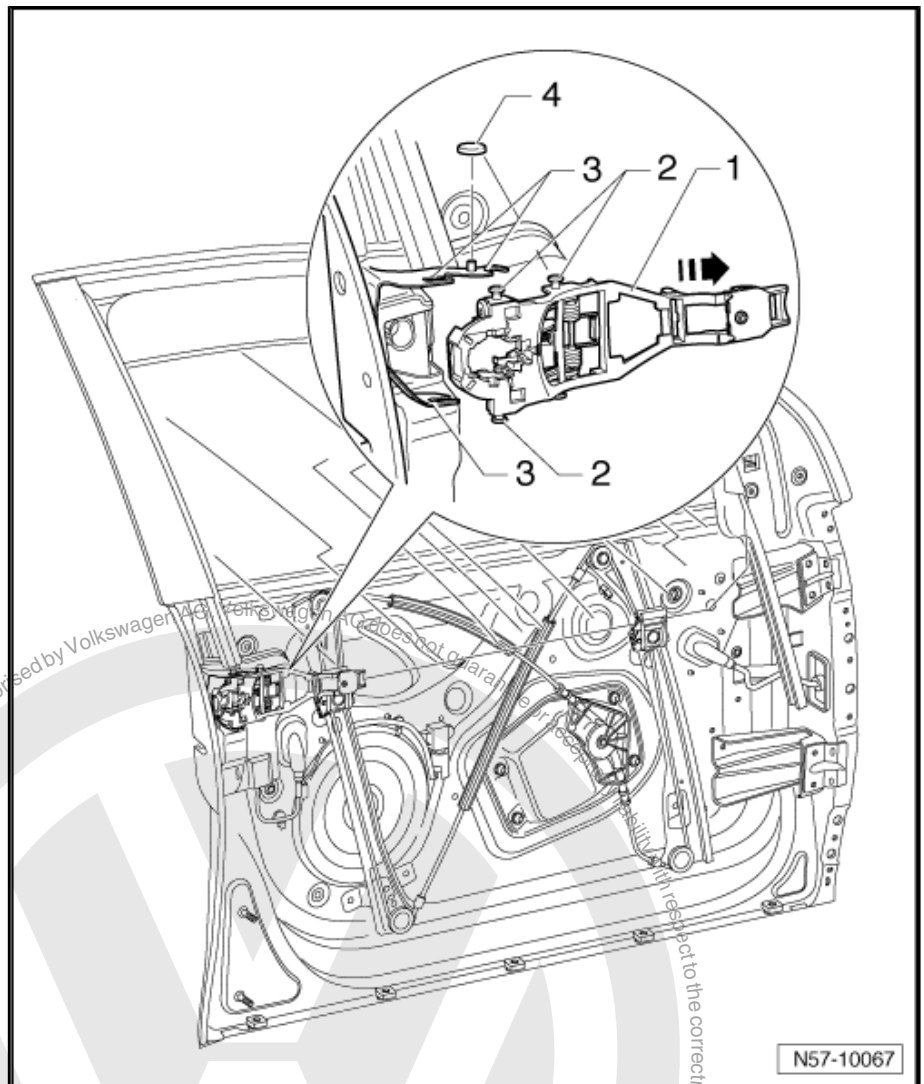

- Remove lock cylinder housing ⇒ [page 67](#)
- Remove door handle ⇒ [page 68](#) .
- Remove door outer panel ⇒ [page 94](#) .
- Pull retaining rubber -4- upwards off guide pins.
- Pull mounting plate -1- in -direction of arrow- with guide pins
-2- out of mounting -3-



1.17.2 Installing

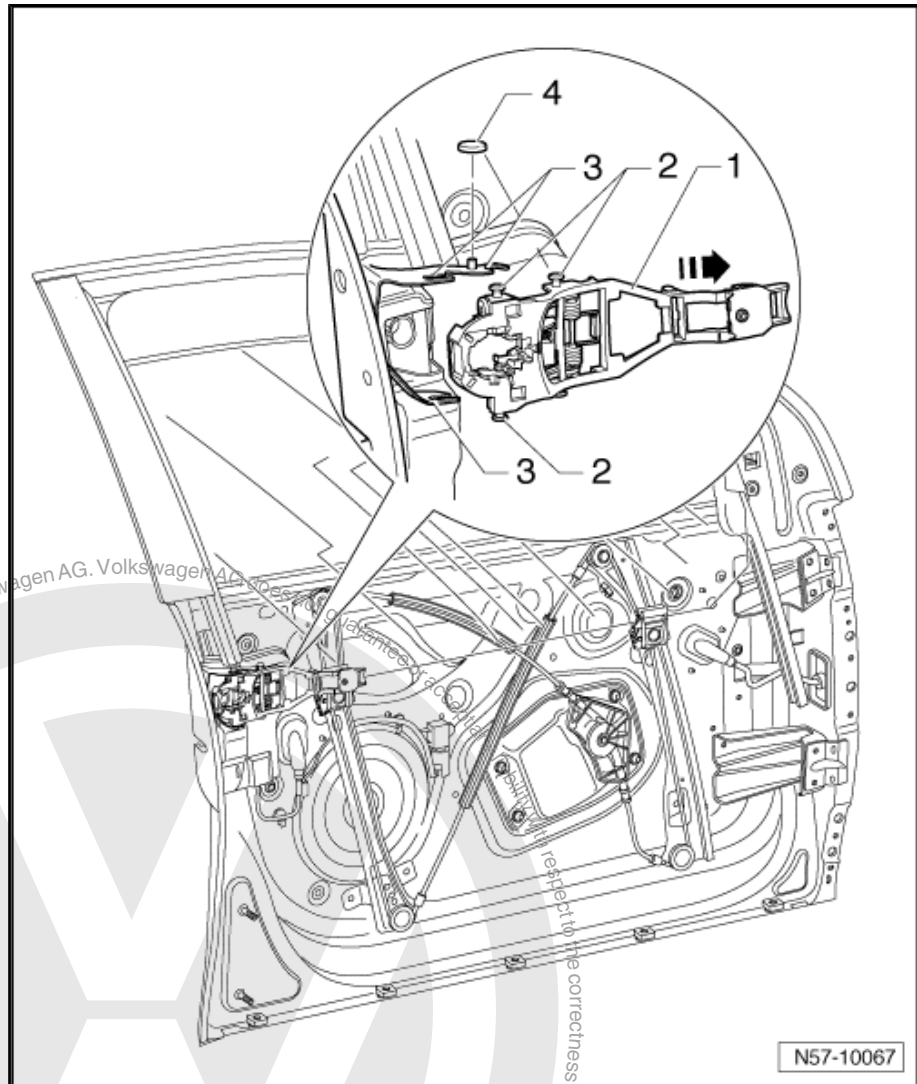

- Push mounting plate -1- with guide pins -2- in mounting -3-.
- Secure retaining rubber -4- to guide pins and securing bolts on mounting plate support.

Further installation is performed in the reverse order of removal.

1.18 Removing and installing door lock



Note

The removal and installation sequence is only for the right door lock. The removal and installation of the left door lock is similar.



1.18.1 Removing

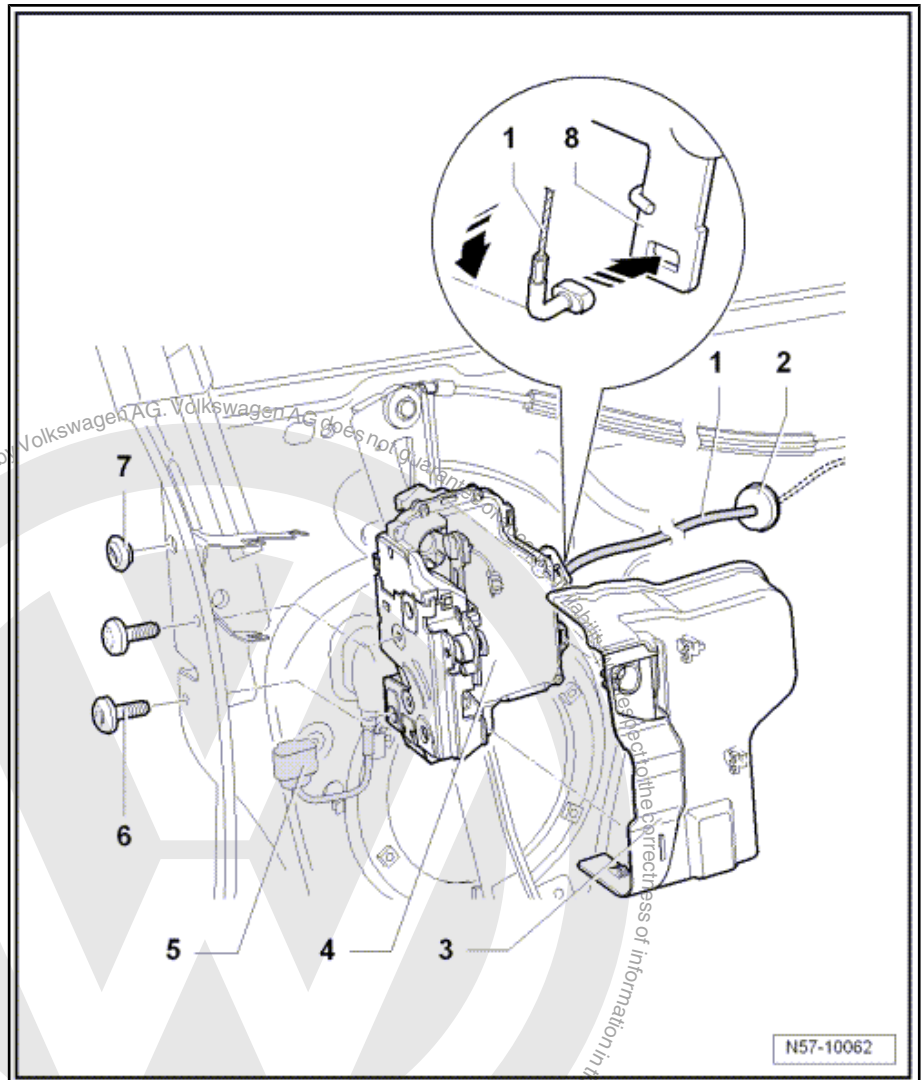

- Remove door outer panel ⇒ [page 94](#) .
- Remove mounting plate ⇒ [page 70](#) .
- Disconnect connector -5-.
- Remove bolts -6-.
- Release cable -1- from relay lever -8- and remove door lock -4-.

Cover -3- is not supplied with door lock.

1.18.2 Installing

Installation is carried out in reverse order of removal.

Specified torque for bolts: 18 Nm.

- Then always check function while door is still open, as an incorrectly fitted and adjusted Bowden cable cannot open the door.



1.19 Assembly overview - side impact protection



Caution

The nuts and bolts of the side impact protection are also painted in the factory. This means that a great deal of force is required to remove them, resulting in some circumstances in the threads shearing. If possible avoid loosening the nuts and bolts.

1 - Side impact protection

2 - Bolt

- Qty. 4
- 20 Nm

3 - Insulation

4 - Nut

- Qty. 2
- 20 Nm

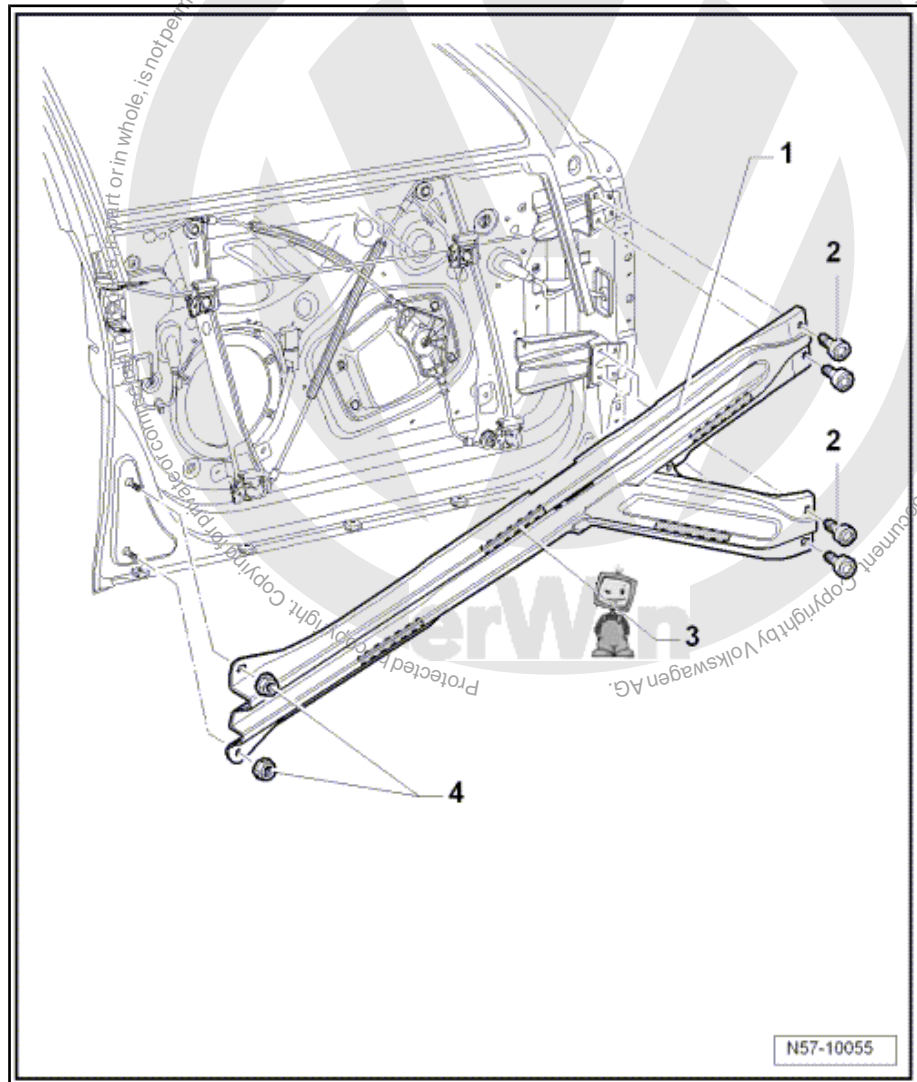

1.20 Door inner seal

During production, a sealant is applied to the door inner seals, which are then placed on the door flange and rolled on.



i Note

- ◆ *When seals are removed, the sealant will spread to the inside of the seal and the flanks will be bent out slightly. If the seal is then refitted, a leak-free tight seal is not guaranteed.*
- ◆ *Therefore each seal which is removed completely should be replaced by a so-called "tap-on" seal.*
- ◆ *If a seal has been partially removed, squeeze sides of seal together before installing.*

1.21 Removing and installing door inner seal

i Note

Removal and installation are described for the left door inner seal only. Removal and installation of the right door inner seal are similar.

1.21.1 Removing

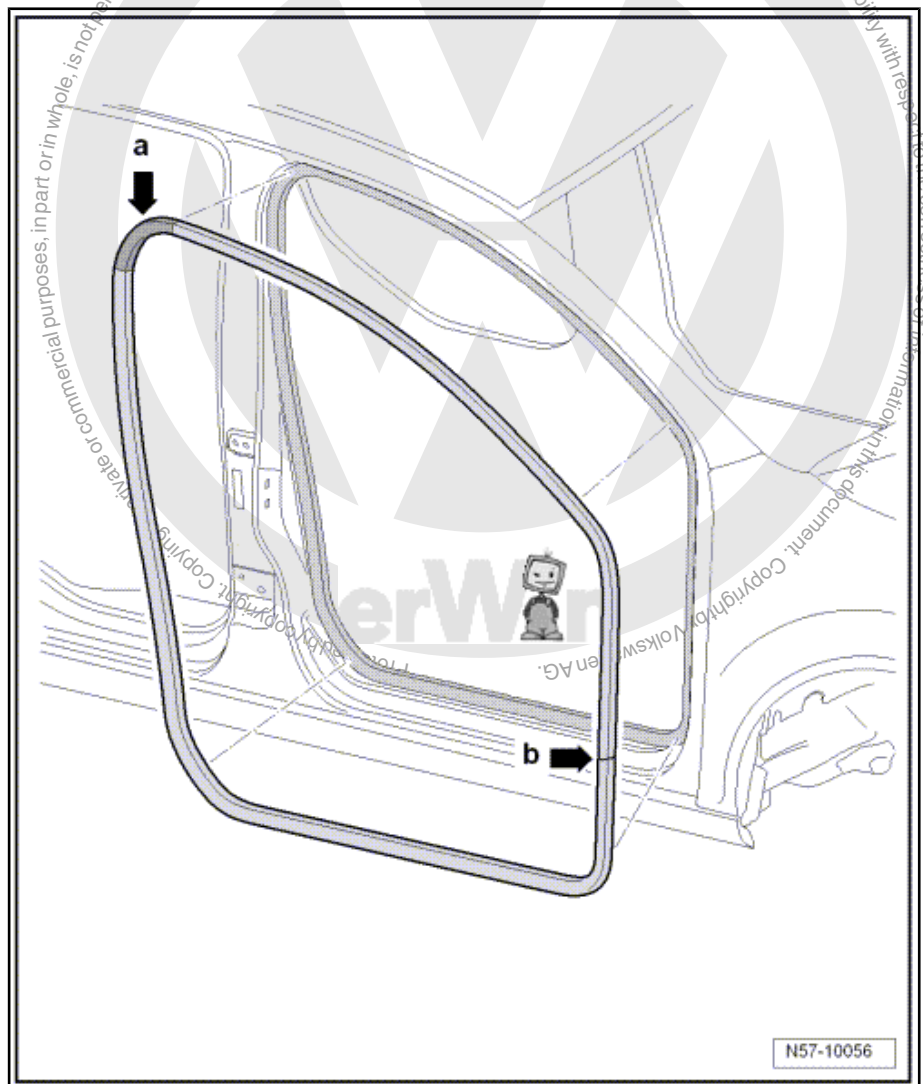



- Pull door inner seal off body flange.

1.21.2 Installing

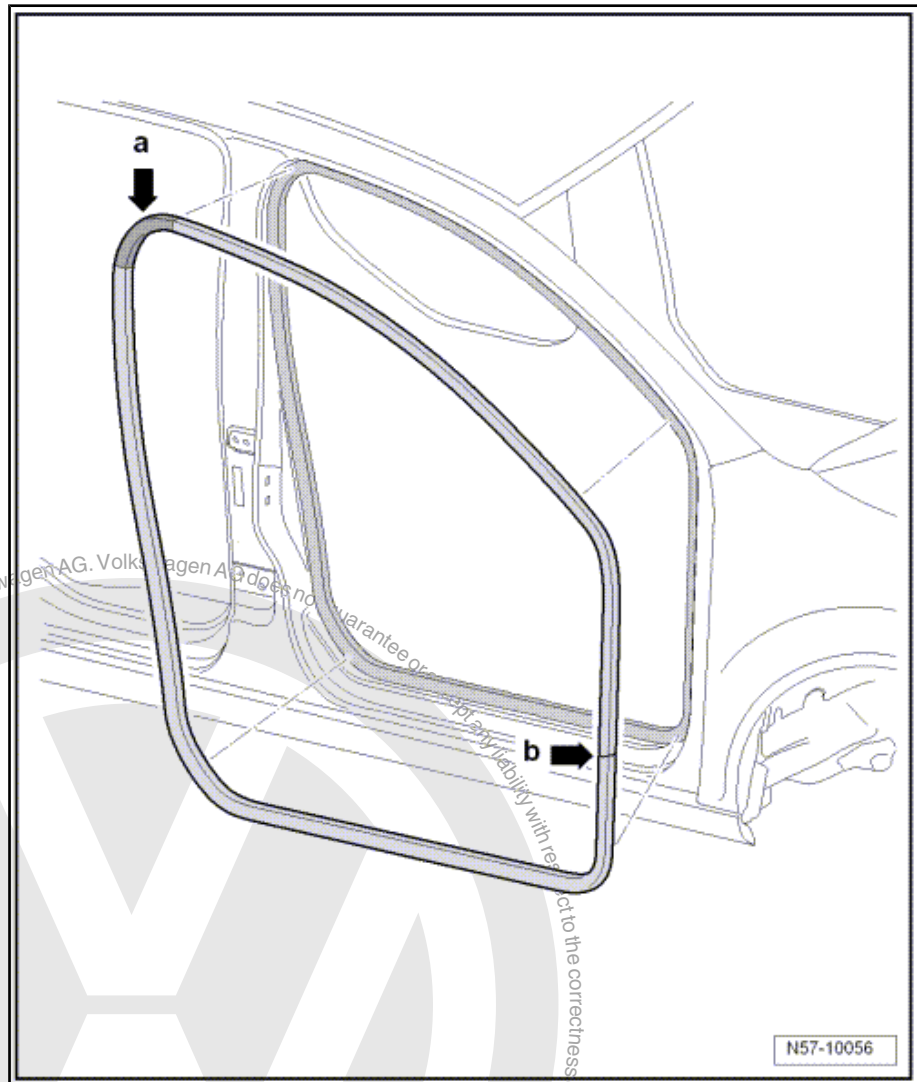

- Align door inner seal with vulcanisation point -arrow b- to height of lower hinge.
- Begin installing door inner seal in upper radius -arrow a- of door aperture.



1.22 Removing and installing door outer seal

Note

- ◆ Removal and installation are described for the right door outer seal only. Removal and installation of the left door outer seal are similar.
- ◆ Remove protective backing immediately before installation. Working temperature approx. 20 °C.
- ◆ Adhesive remover D 002 000 10 must be used exclusively.
- ◆ The door outer seal must be bonded in place immediately after cleaning.
- ◆ After 10 minutes, check to ensure that the seal is firmly seated.

1.22.1 Removing

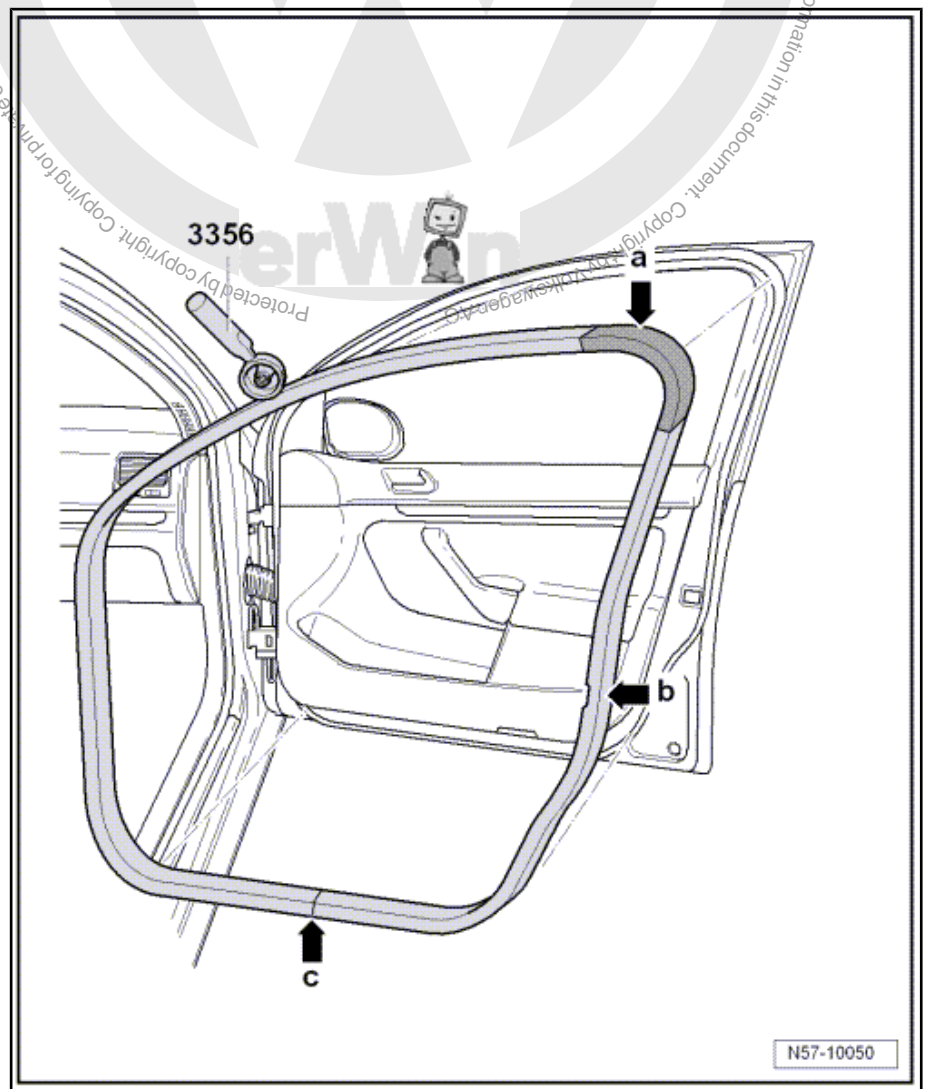

- Pull door outer seal off door.



1.22.2 Installing

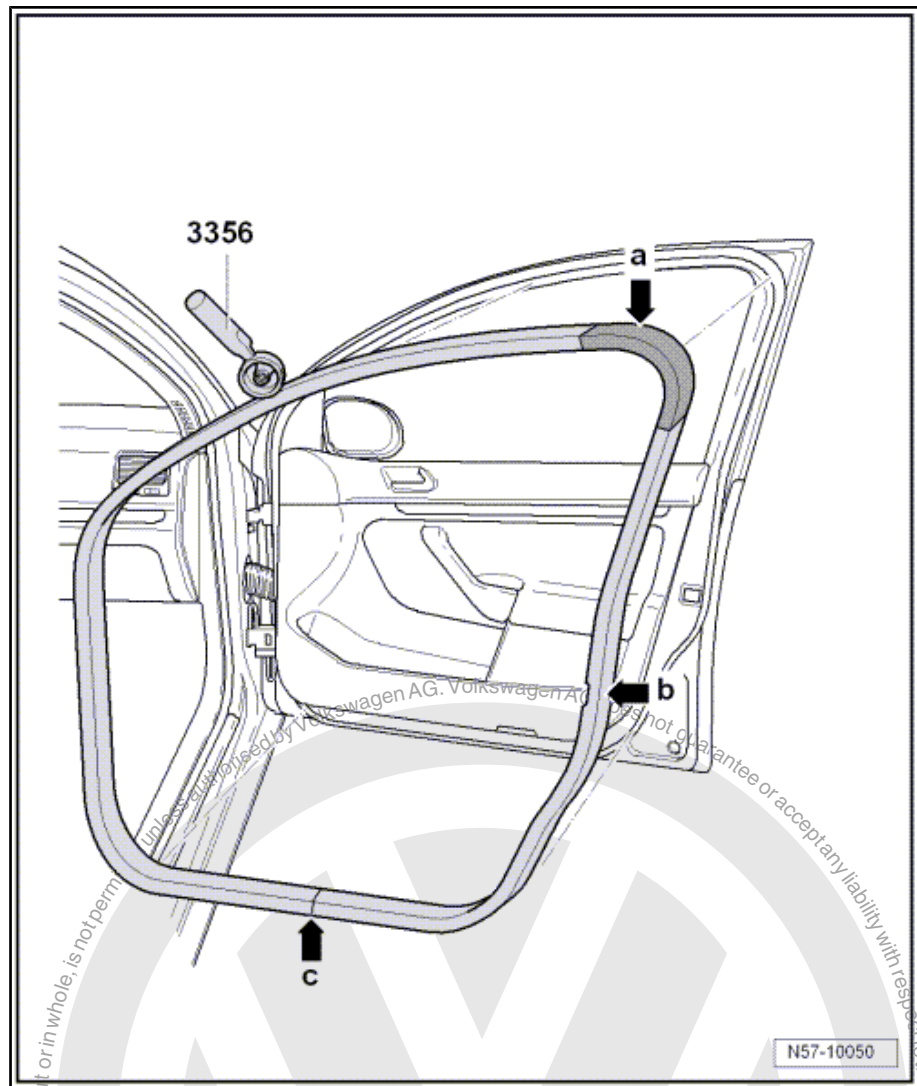

- Remove existing adhesive residues with adhesive remains remover -VAS 6349- .
- Immediately before bonding the door outer seal, clean bonding surface thoroughly with adhesive remover D 002 000 10.
- Surfaces to be bonded must be free of dust and grease and there should be no adhesive residue.
- Align door outer seal with aperture -arrow b- towards door lock securing bolt.
- Door outer seal vulcanised point -arrow c- should then be in middle of side member.
- Pull protective backing off in stages and start fitting seal in upper radius -arrow a- of door. Do not pull outer door seal to avoid stretching seal.

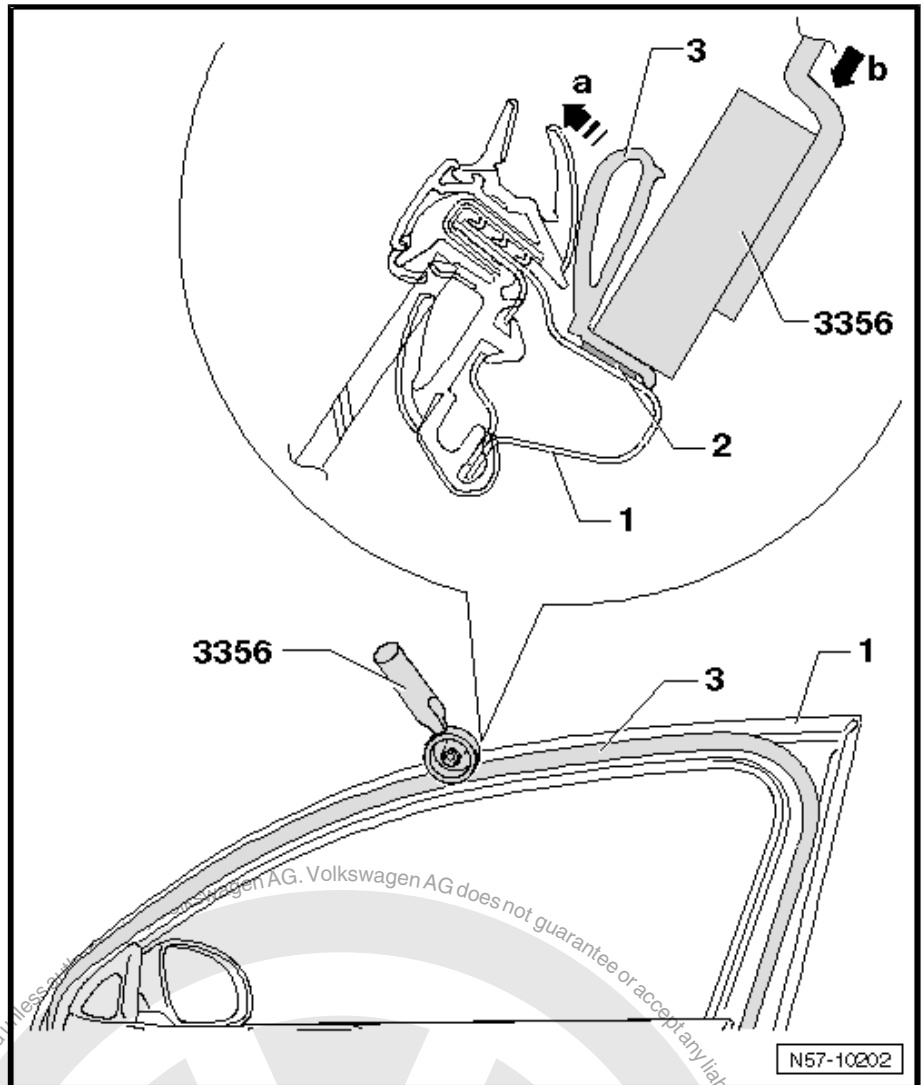

- Press complete adhesive area of seal -3- on door -1- all around using roller -3356- .
- The seal is pushed aside -arrow a- when doing this so that the roller -3356- runs directly over the contact surface of the seal.

The roller can only apply the necessary force -arrow B- to the adhesive surface -2- when procedure described above is followed correctly.

- If the seal is too long: cut seal to required length and press butt joints on well.
- If the seal -3- comes loose in small areas again, press seal on well again using roller -3356- .

i Note

The door must not be closed for a period of 2 hours to ensure the door outer seal does not move or loosen again.



2 Central locking

2.1 Location overview - central locking components

1 - Coupling station

- Location: right-hand A-pillar
- To disconnect connector, release boot at pillar
⇒ [page 51](#)

2 - Convenience system central control unit J393

- Location: beneath dash panel on front passenger side, behind glove compartment
- Removing ⇒ General body repairs, interior; Rep. Gr. 68 ; Interior equipment; Covers, compartments and trims; Removing and installing glove compartment

3 - Front passenger door control unit J387

- Integrated in window regulator motor
- Removing ⇒ [page 199](#)

4 - Door lock

- Door lock is secured to door inner part
- Electric central locking is integrated in door lock
- Removing ⇒ [page 73](#)

5 - Coupling station

- Fitting location: right B-pillar.
- To separate connector, loosen boot at pillar ⇒ [page 90](#)

6 - Rear right door control unit J389

- Integrated in window regulator motor
- Removing ⇒ [page 213](#)

7 - Door lock

- Door lock is secured to door inner part
- Electric central locking is integrated in door lock
- Removing ⇒ [page 111](#)

8 - Coupling station, right side of rear lid

- Fitting location: behind C-pillar trim
- Removing and installing ⇒ General body repairs, interior; Rep. Gr. 70 ; Trim/insulation; Pillar and side panel trim; Removing and installing C-pillar upper trim

9 - Fuel tank filler cap flap release motor V155

- Fitting location: behind right trim of load compartment.

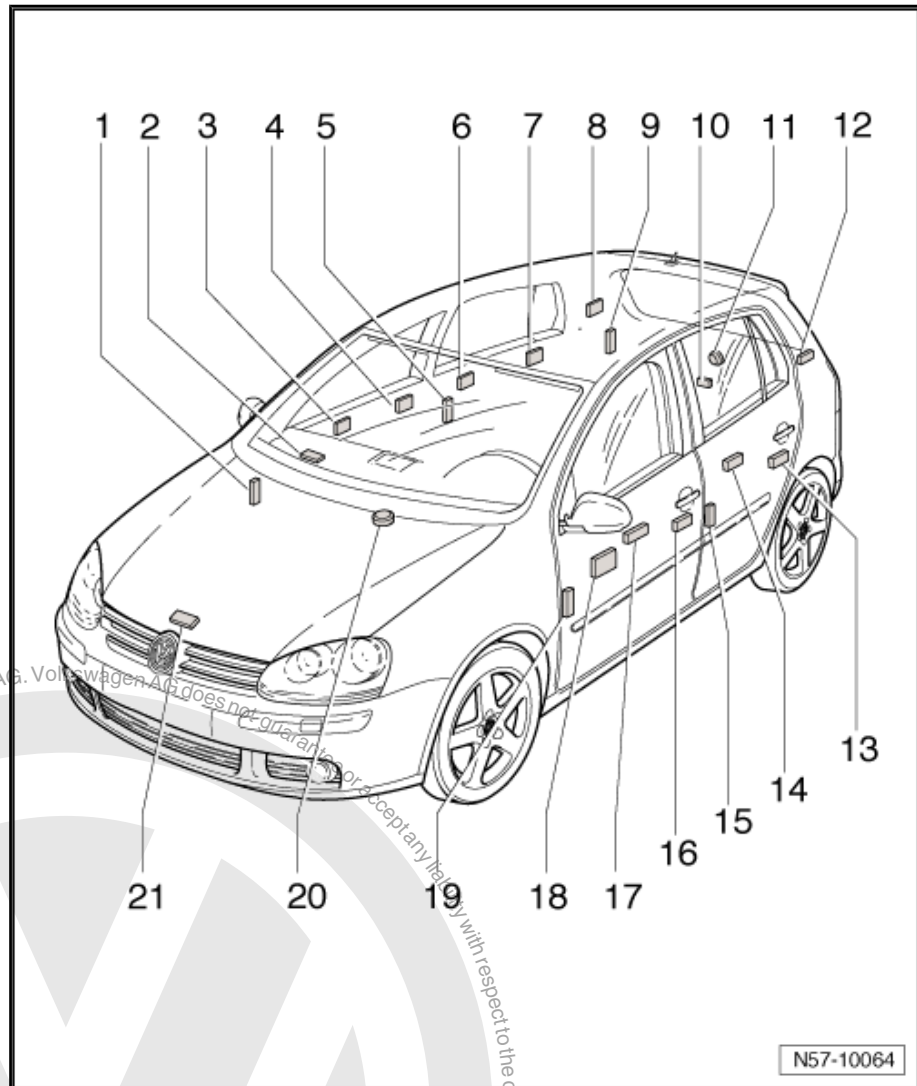



- Removing ⇒ [page 44](#)

10 - Rear lid lock

- Fitting location: bolted to rear lid.
- Removing ⇒ [page 39](#)

11 - Release element with button

- Fitting location: bolted in rear lid.
- Removing ⇒ [page 38](#)

12 - Coupling station, left side of rear lid

- Fitting location: behind C-pillar trim.
- Removing and installing ⇒ General body repairs, interior; Rep. Gr. 70 ; Trim/insulation; Pillar and side panel trim; Removing and installing C-pillar upper trim

13 - Rear left door lock

- Door lock is secured to door inner part
- Electric central locking is integrated in door lock
- Removing ⇒ [page 111](#)

14 - Rear left door control unit J388

- Integrated in window regulator motor
- Removing ⇒ [page 213](#)

15 - Coupling station

- Fitting location: left B-pillar
- To separate connector, loosen boot at pillar ⇒ [page 90](#)

16 - Front left door lock

- Door lock is secured to door inner part
- Electric central locking is integrated in door lock
- Removing ⇒ [page 73](#)

17 - Central switch for window regulator

- Fitting location: installed in door trim
- Removing and installing centralized switches for window regulators ⇒ Vehicle electrical system; Rep. Gr. 96 ; Electrical system; Interior lights, lamps, switches; Lights and switches in doors

18 - Front left door control unit J386

- Integrated in window regulator motor
- Removing ⇒ [page 199](#) and ⇒ [page 73](#)

19 - Coupling station

- Fitting location: left A-pillar.
- To separate connector, loosen boot at pillar ⇒ [page 51](#)

20 - Anti-theft alarm horn

- Fitting location: under right wing.
- Removing ⇒ Electrical system; Rep. Gr. 96 ; Lights, bulbs, switches - interior; Anti-theft protection; Anti-theft alarm system (ATA); Alarm horn H12

21 - Bonnet contact switch F266

- Anti-theft alarm (ATA) contact switch
- Fitting location: on bonnet lock.
- Removing ⇒ Electrical systems; Rep. Gr. 96 ; Lights, bulbs, switches - interior; Anti-theft protection; Lights and switches in engine compartment; Removing and installing bonnet contact switch F266

2.2 Adapting keys with remote control

Keys with remote control can be adapted using the vehicle diagnosis, testing and information system -VAS 5051 A- .



- Select "guided fault finding" in diagnostic tester -VAS 5051 A- .
- Using the "GoTo" key, select "Function/component selection" and the following menu items one after the other:
 - ◆ Body
 - ◆ General body repairs
 - ◆ 01 - Self-diagnosis capable systems
 - ◆ Convenience systems
 - ◆ Functions - convenience system central control unit
 - ◆ Checking/adapting key with remote control J393

2.3 Assembly overview - battery for folding key with remote control

1 - Key with variable code transponder

2 - Transmitter unit - upper part

3 - LED

- When remote control is operated, this LED must light up
- If LED does not flash during remote control operation, the battery is dead and must be renewed

4 - Battery

- Removing battery
⇒ [page 83](#)
- Installing battery
⇒ [page 83](#)

5 - Transmitter unit - lower part

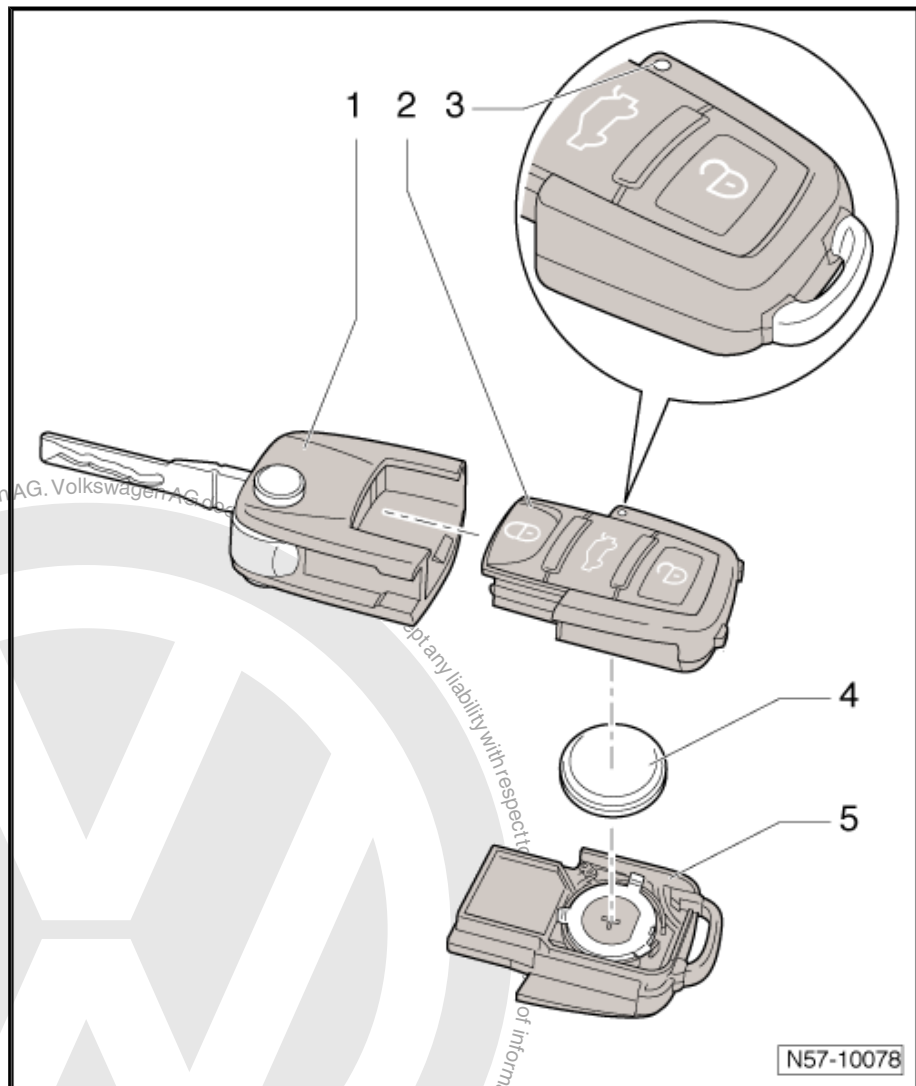



2.4 Removing and installing battery for folding key with remote control

2.4.1 Removing

- Insert a screwdriver in slot between transmitter unit -1- and key -2-.
- Twist screwdriver in -direction of arrow- to separate transmitter unit from key.

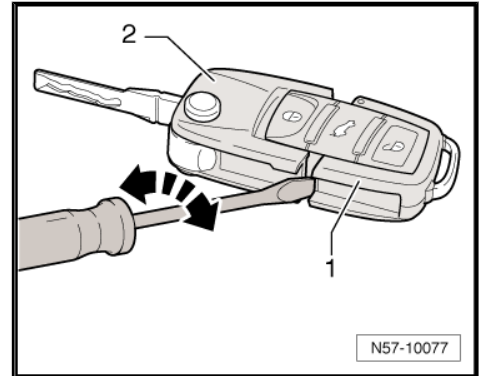

- Press transmitter unit -1- apart using profile section of key -2-.

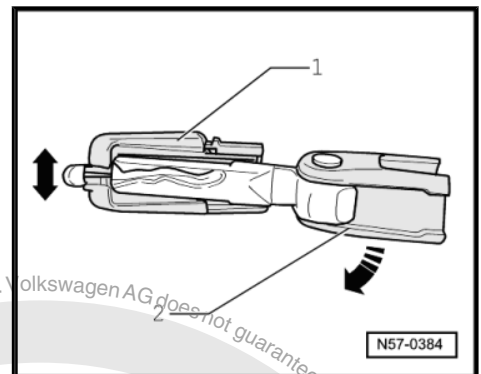

- Unclip battery -1- from retainers -2- with a screwdriver in -direction of arrow-.

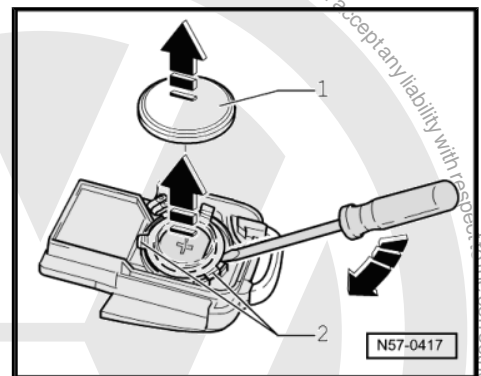

2.4.2 Installing



Note

- ◆ Before installing battery, always press any key once.
- ◆ Thus transmitter unit is reset and can recognize a new battery only now.



Note polarity and correct position when installing battery.

- Lay battery -1- with positive terminal downwards in sender unit
- 2- (positive terminal is marked on housing).
- Engage battery in transmitter body by pressing down lightly.
- Fit cover to transmitter body (do not damage seal).
- Then clip transmitter unit to key.

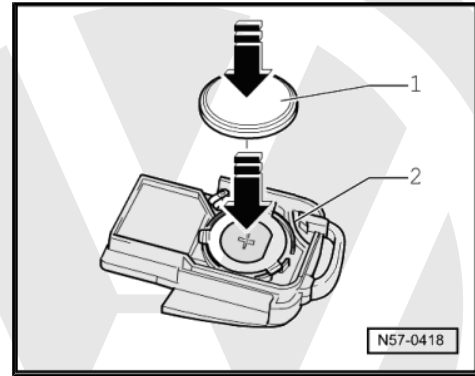



58 – Rear doors, door components

1 Rear door

1.1 Tools

Special tools and workshop equipment required

- ◆ Socket -T 10072-
- ◆ Assembly tool -T 10118-
- ◆ Door alignment tool -3320-
- ◆ Universal joint for 3320 -3320/1-
- ◆ Bit for 3320 -3320/2-
- ◆ Bit for 3320 -3320/3-
- ◆ Roller for fitting door insulation foil -3356-
- ◆ Torque wrench 5...50 Nm - V.A.G 1331-
- ◆ Setting gauge -3371-

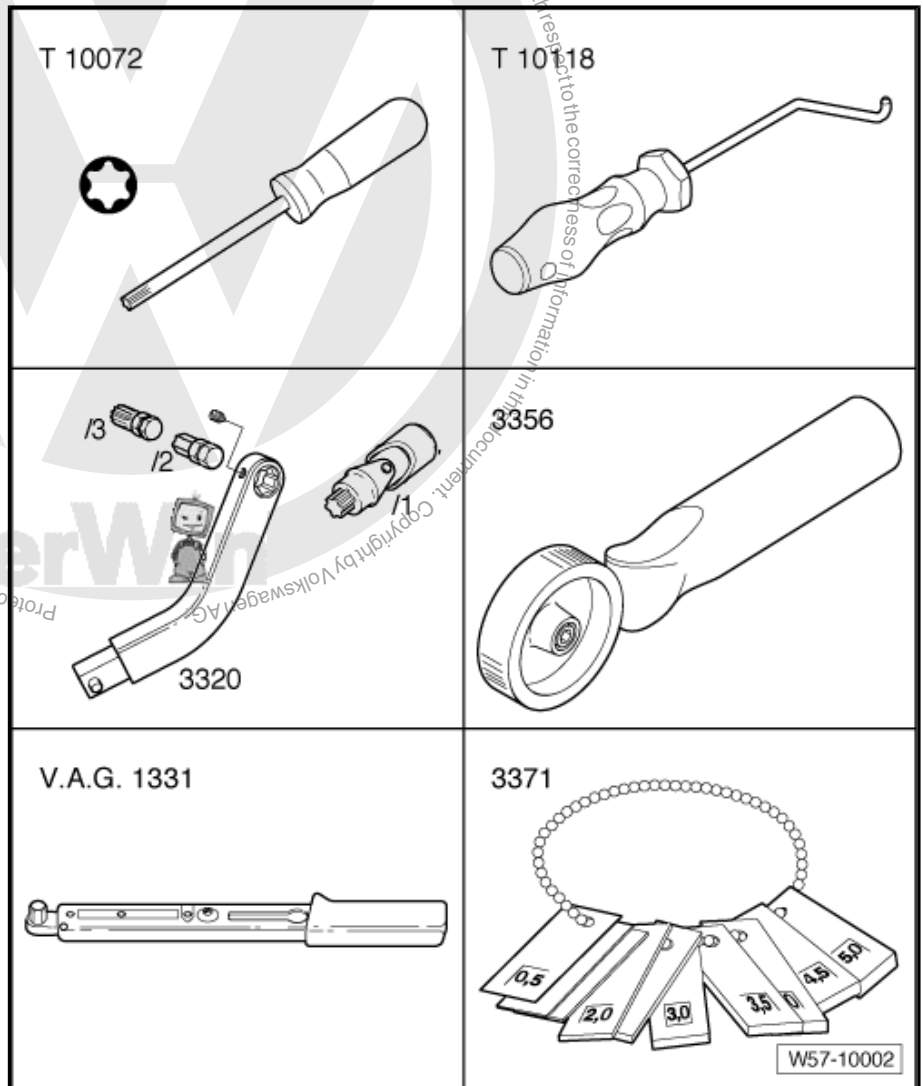



- ◆ Cartridge gun -V.A.G 1628-
- ◆ Cartridge heater -V.A.G 1939 A-
- ◆ Wedge -3409-
- ◆ Assembly tool set -T 10237-

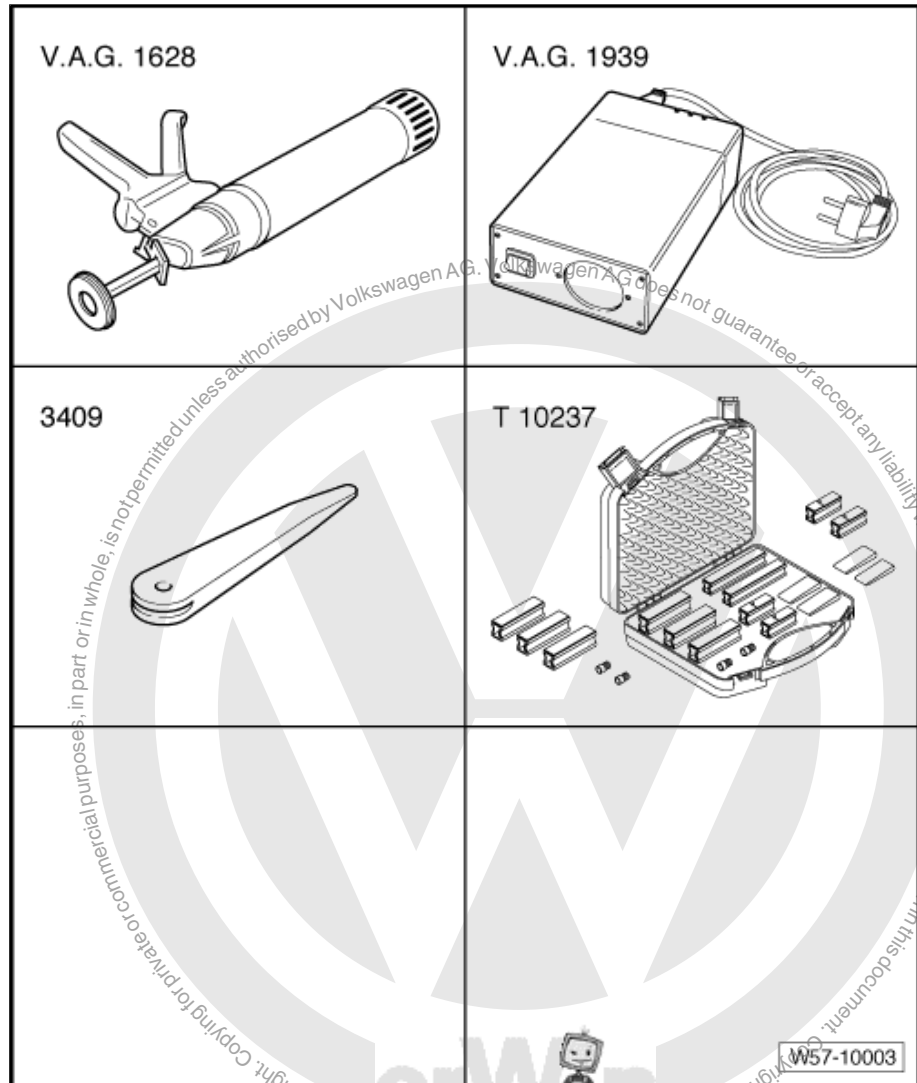

1.2 Materials

- ◆ 1K window adhesive DH 009 100 01^{6) 7)}
- ◆ Glass primer/paint primer D 009 200 02⁵⁾
- ◆ Cleaning solution D 009 401 04⁵⁾
- ◆ Primer applicator D 009 500 25⁵⁾
- ◆ Door repair kit D 438 520 A2⁸⁾

5) Materials are stored in box D 004 700.

6) Observe minimum curing period ⇒ [page 103](#) .

7) Heat, according to manufacturers instructions, using cartridge heater -V.A.G 1939- .

8) Folding cardboard carton with 10 sheets each with 15 adhesive strips.

1.3 Assembly overview - door assembly

A new door concept has been introduced with Golf 2004.

The door consists of a door inner part -6- and door outer panel -1-.



The parts are joined by the front -7- and rear -4- retaining rails.

The retaining rails are bolted to the door inner part and bonded to the door outer panel.

Loudspeaker, window regulator, window regulator motor, wiring, window guide and door lock are mounted on the door inner part.

The door outer panel -1- is additionally bolted to the lower edge of the door inner part. The window slot seals, insulation and door outer handle are mounted on the door outer panel.

1 - Door outer panel

- Removing and installing door outer panel
 => [page 94](#)

2 - Edge protection

- Between door outer skin and door inner panel

3 - Bolt

- Feature: bolt with pointed end and thin washer.
- Qty. 4 on lower edge
- Qty. 2 in area of top section of trim
- 10 Nm

4 - Rear retaining rail

- Adhesive: DH 009 100 03

5 - Bolt

- Feature: bolt without pointed end but with thick washer.
- Qty. 11 on both retaining rails
- 14 Nm

6 - Door inner part

- Assembly overview
 => [page 104](#)

7 - Front retaining rail

- Adhesive: DH 009 100 03

8 - Bolt

- Feature: bolt with pointed end and thick washer.
- Qty. 1 for front area of top section of trim
- 10 Nm

9 - Insulation

- Self-adhesive
- To bond, first heat the insulation and then press on firmly

10 - Clip

- Qty. 5

11 - Window slot seal

- Must be fitted before assembling door outer panel

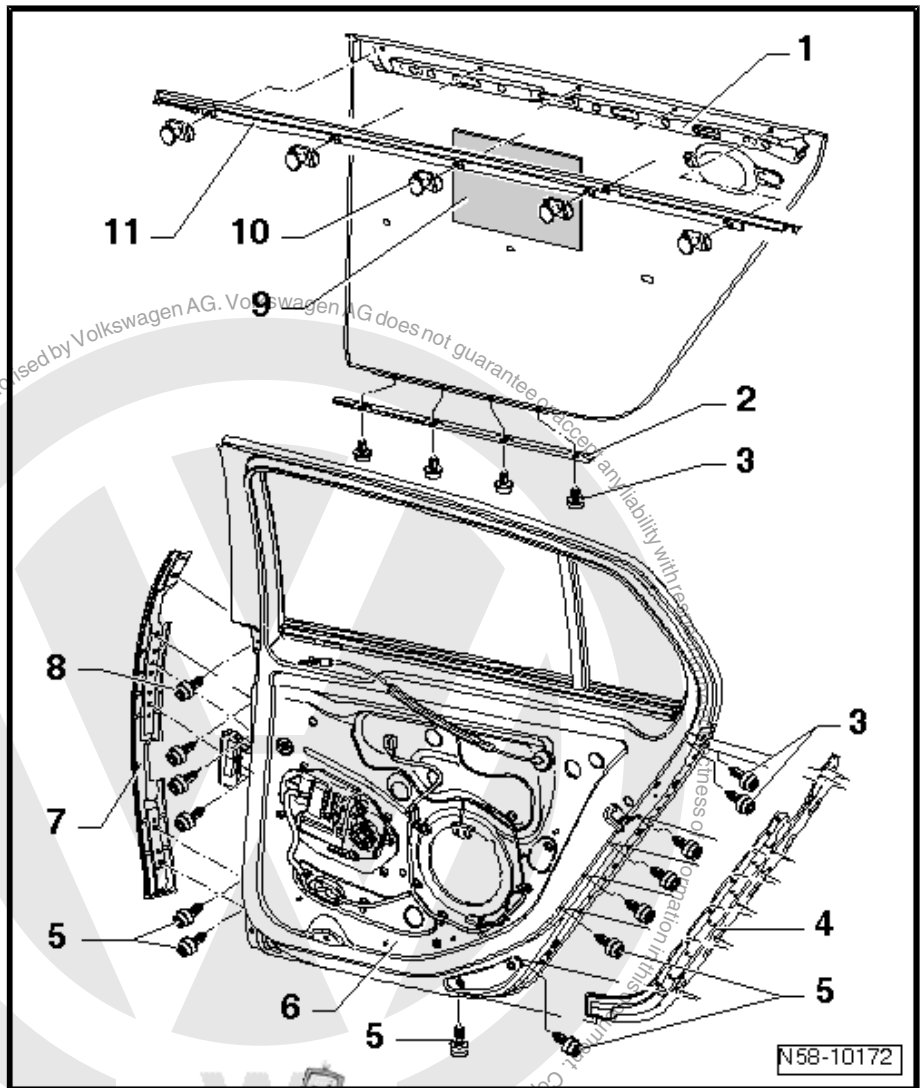



1.4 Assembly overview - door hinges



Caution

Bolt of eccentric pin -10- should not be loosened under any circumstances on vehicles up to 01.2004. It cannot be tightened again using normal workshop tools.



Note

- ◆ The right side is shown. The left side is similar.
- ◆ The hinge bolts must always be renewed if loosened.
- ◆ Hinges are now one piece.
- ◆ The specified torque for the hinge bolts to the door (bolts -4, 6 and 14-) has been revised.

1 - Door

- Removing and installing
⇒ [page 89](#)
- Adjusting ⇒ [page 91](#)

2 - Guide bolt

- 10 Nm

3 - Door hinge with arrester

4 - Multi-point socket head bolt

- 50 Nm
- Bolts must always be replaced by new ones after being undone

5 - Multi-point socket head bolt

- Installed from inside the vehicle
- Remove B-pillar lower trim ⇒ General body repairs, interior; Rep. Gr. 70 ; Trim/insulation; Pillar and side panel trim
- 20 Nm + 1/4 turn further (90°).
- Bolts must always be renewed after being loosened

6 - Multi-point socket head bolt

- 50 Nm
- Bolts must always be renewed after being loosened

7 - Multi-point socket head bolt

- 20 Nm + 1/4 turn further (90°).
- Bolts must always be replaced by new ones after being undone

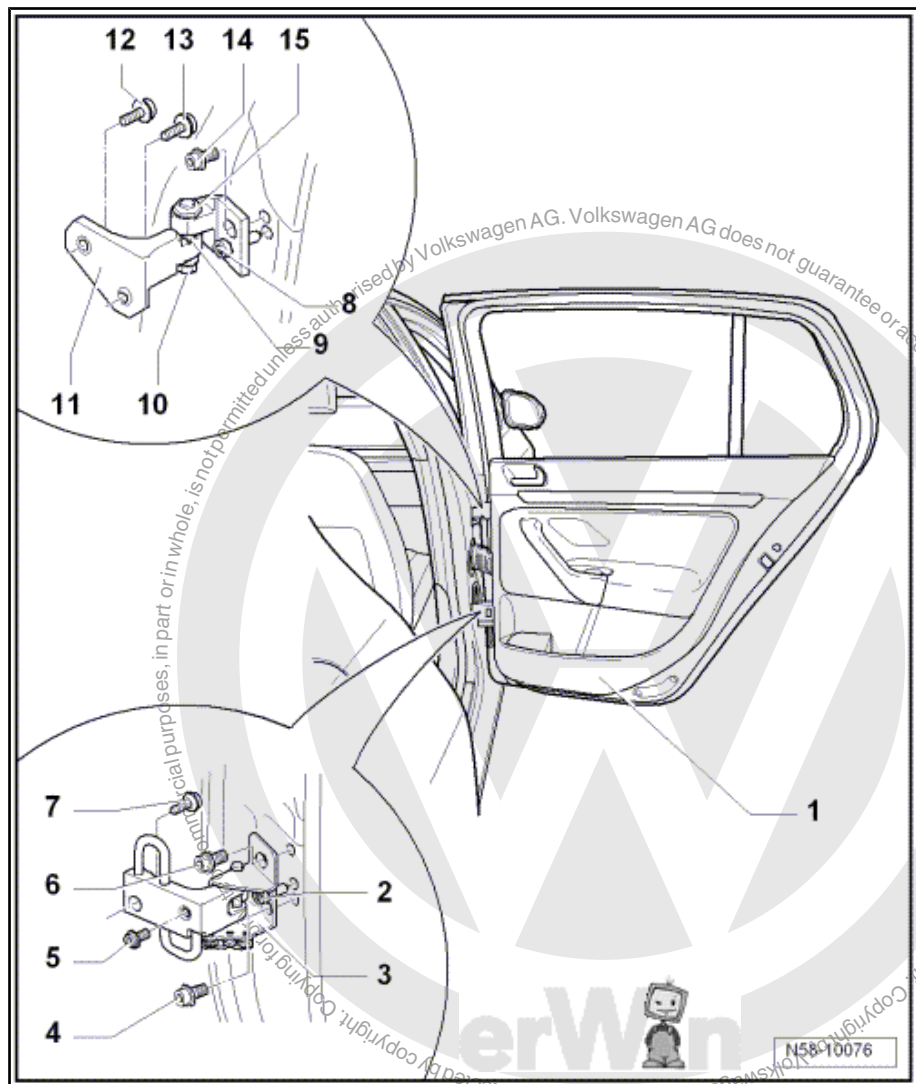



8 - Guide bolt

- 10 Nm

9 - Adjustment ring

- Restricts the adjustment range for the eccentric pin

10 - Bolt

- 28 Nm
- For eccentric pin

11 - Door hinge

- Door hinge no longer comprises of more than one part

12 - Multi-point socket head bolt

- 20 Nm + 1/4 turn further (90°).
- Bolts must always be renewed after being loosened

13 - Multi-point socket head bolt

- 20 Nm + 1/4 turn further (90°).
- Bolts must always be replaced by new ones after being undone

14 - Multi-point socket head bolt

- 50 Nm
- Bolts must always be replaced by new ones after being undone

15 - Eccentric pin

- Eccentric pin is used to adjust gap on vehicles as of 02.2004

1.5 Removing and installing door



Note

*The removal and installation sequence is only for the right door.
 The removal and installation of the left door is similar.*

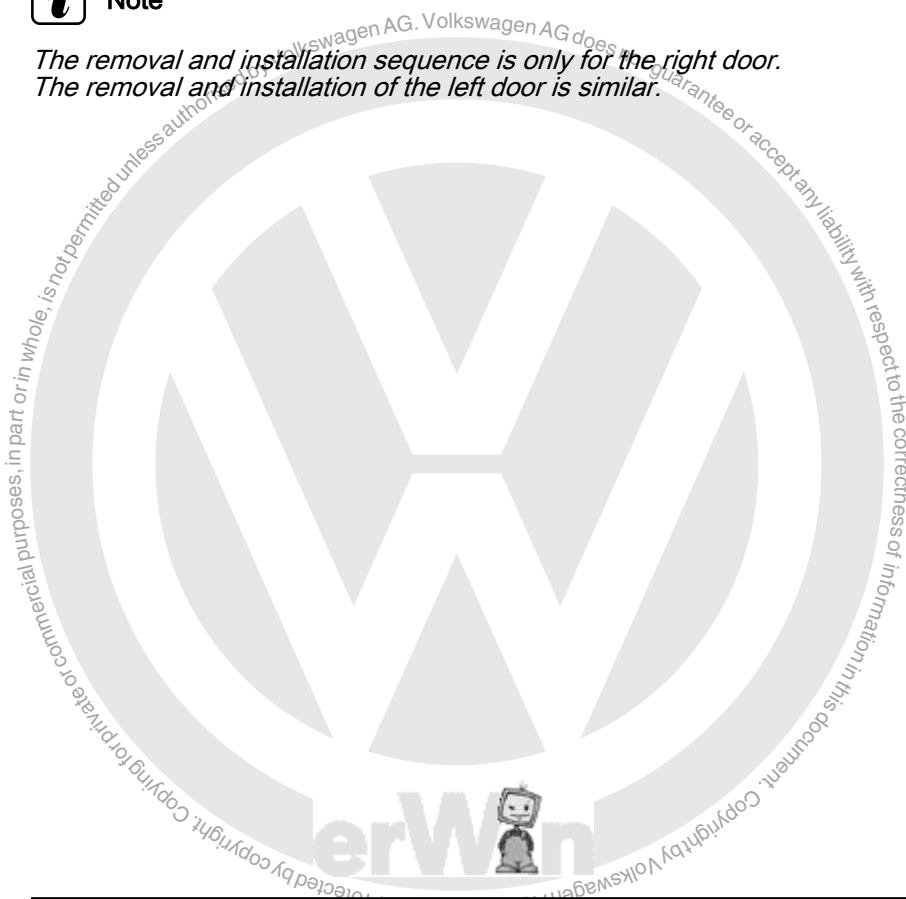



1.5.1 Removing

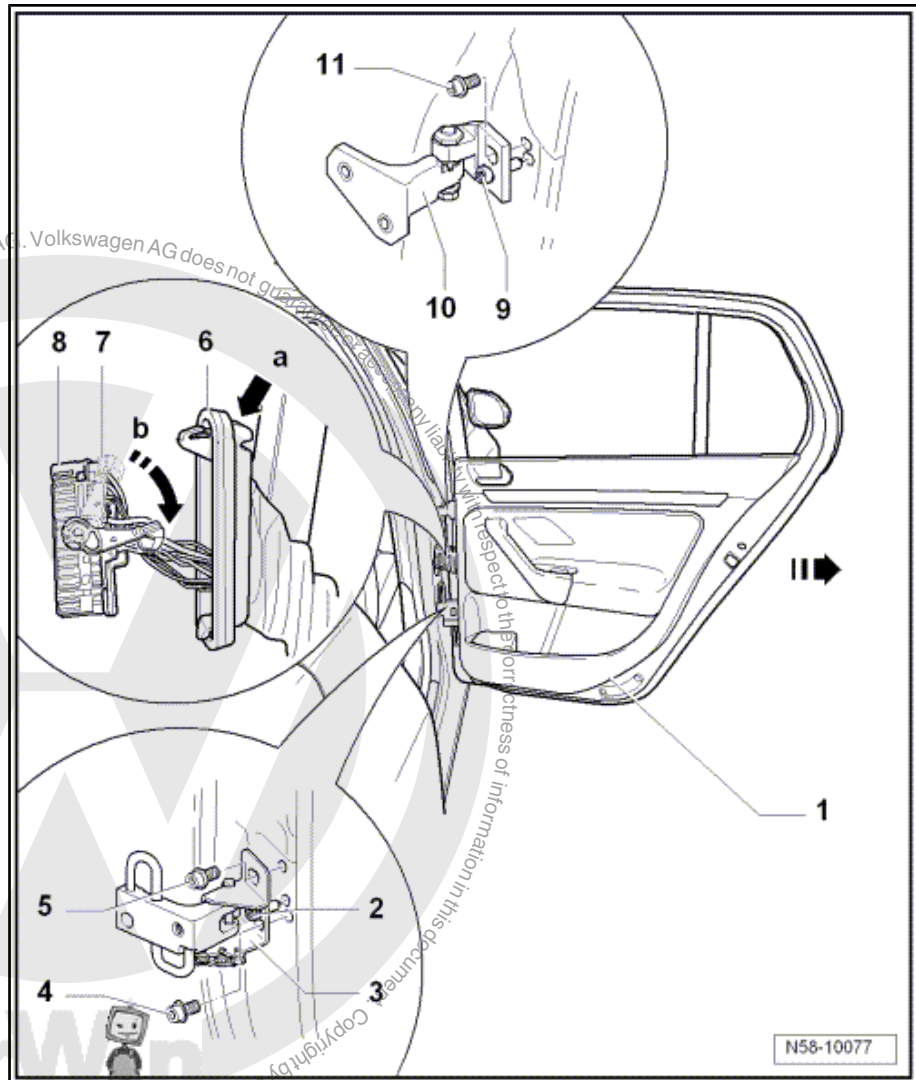

- Release bellows -6- by pressing catch -arrow a- and pull bellows off B-pillar.
- Swing release lever -7- downwards -arrow b- and disconnect electrical connector -8- from coupling station.
- Remove bolts -4, 5 and 11- from hinge using special door alignment tool -3320- and bit -3320/3- .
- Pull door in -direction of arrow- off guide bolts -3 and 9-.

1.5.2 Installing

Installation is carried out in reverse order of removal.

- Specified torque for bolts -4, 5 and 11-: 50 Nm.
- Always renew bolts -4, 5 and 11-.
- Note rear door gaps ⇒ Body Repairs; Rep. Gr. 00 ; Technical data; Body panel gaps/shut lines .



1.6 Adjusting door



Note

- ◆ *The door is adjusted correctly if the gaps/shut lines are even all around, the door is not too deep or does not stand proud and all contours align when the door is closed.*
- ◆ *Vehicle must be standing on its wheels on flat level ground when adjustments are performed.*
- ◆ *If door outer panel has been removed, door inner part window frame must be adjusted to roof frame and B-pillar, or rear door.*

1.6.1 Adjusting door gaps

Special tools and workshop equipment required

- ◆ Box spanner 15 mm -T10344-

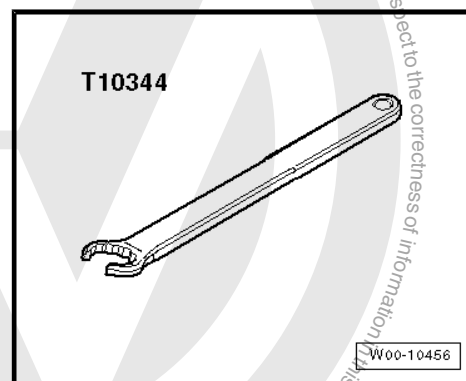

WARNING

Vehicles up to 01.2004, the bolt of the eccentric pin -4- must not be loosened and the eccentric pin -6- must not be used to adjust the door.

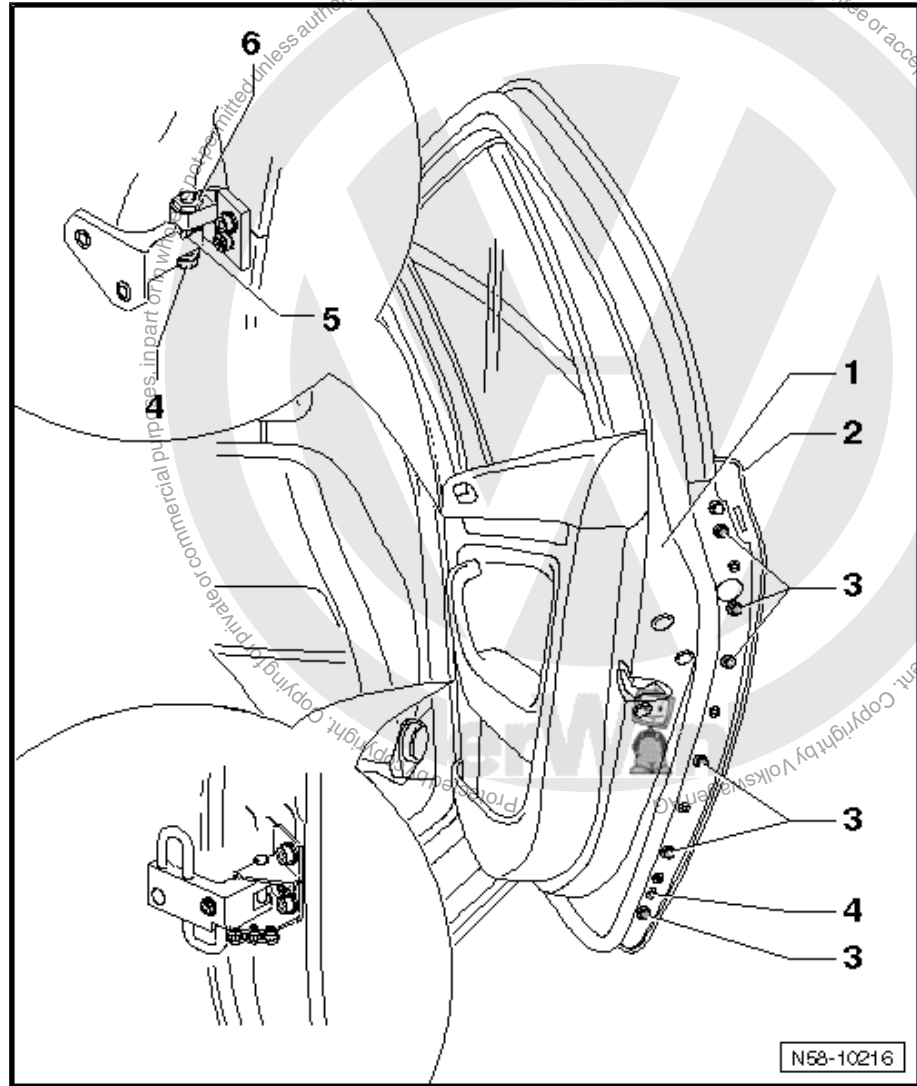

- Note front door gap dimensions ⇒ Body Repairs; Rep. Gr. 00 ; Technical data; Body gap dimensions .

Adjustments are carried out using eccentric pin -7-.

Other measures such as raising the door have no effect. Subsequent pressure from above will cause the door to sack again.

- Loosen bolt for eccentric pin -4-.
- Adjust eccentric pin -6- within adjustment range -5- using 15 mm ring spanner -T10344- .
- Tighten bolt -4- before checking setting.

If the adjustment range is insufficient, the door outer panel -2- can be adjusted.

- Loosen bolts -3- and move door outer panel -2-.
- Retighten bolts -3- ⇒ [page 57](#) .



1.6.2 Adjusting door fittings for flushness

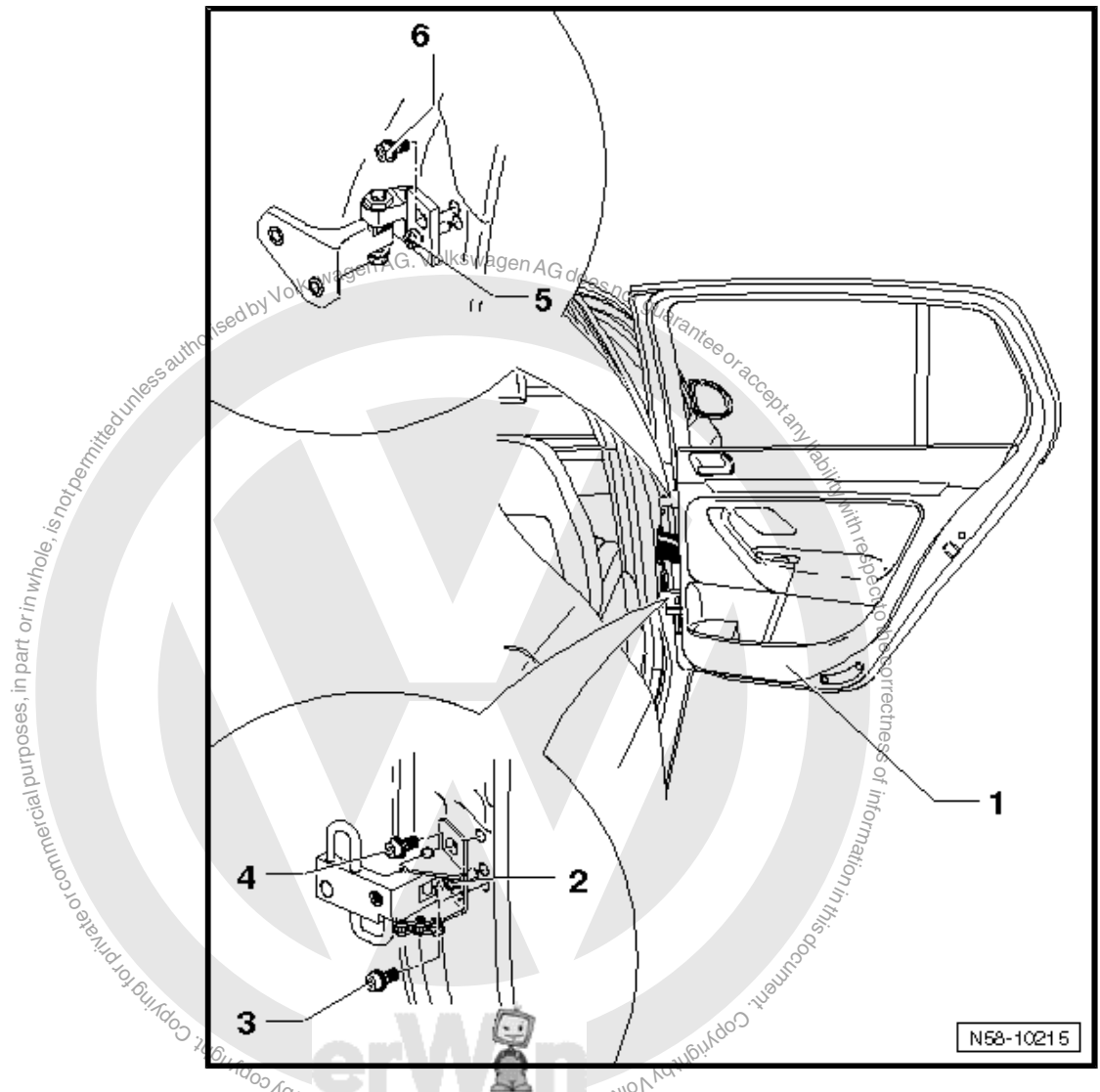

Use bolts -2, 3, 4, 5 and 6- on hinge to adjust correctly for flushness.

Use door alignment tool -3320- with bit -3320/3- .

- Adjusting upper area of door, loosen bolts -5 and 6-.
- Specified torque for bolt -5-: 10 Nm.
- Specified torque for bolt -6-: 50 Nm.
- To adjust lower area of door, loosen bolts -5 and 6-.
- Specified torque for bolt -2-: 10 Nm.
- Specified torque for bolts -3 and 4-: 50 Nm.

The bolts -3, 4 and 6- must always be renewed if loosened.

- Guide pin -4- may be ground down if necessary.



1.7 Removing and installing door outer panel

1.7.1 Removing

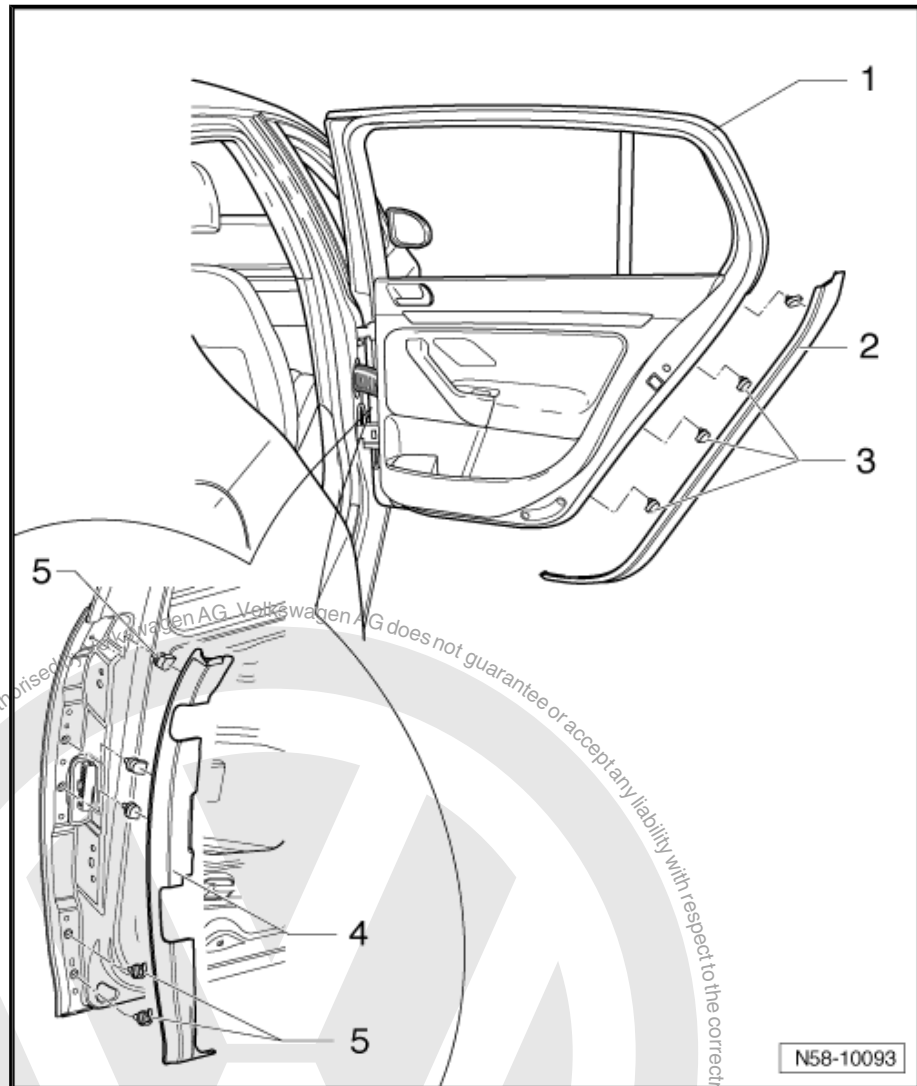

- Lever out clips -3- from the bottom starting on the door -1- and remove rear cover -2-.
- Lever out clips -5- from the bottom starting on the door -1- and remove rear cover -4-.



- Remove lock cylinder housing: ⇒ [page 67](#) .
- Remove door handle ⇒ [page 68](#) .
- Remove bolt -1- from mounting bracket -2- which is located behind door outer panel.

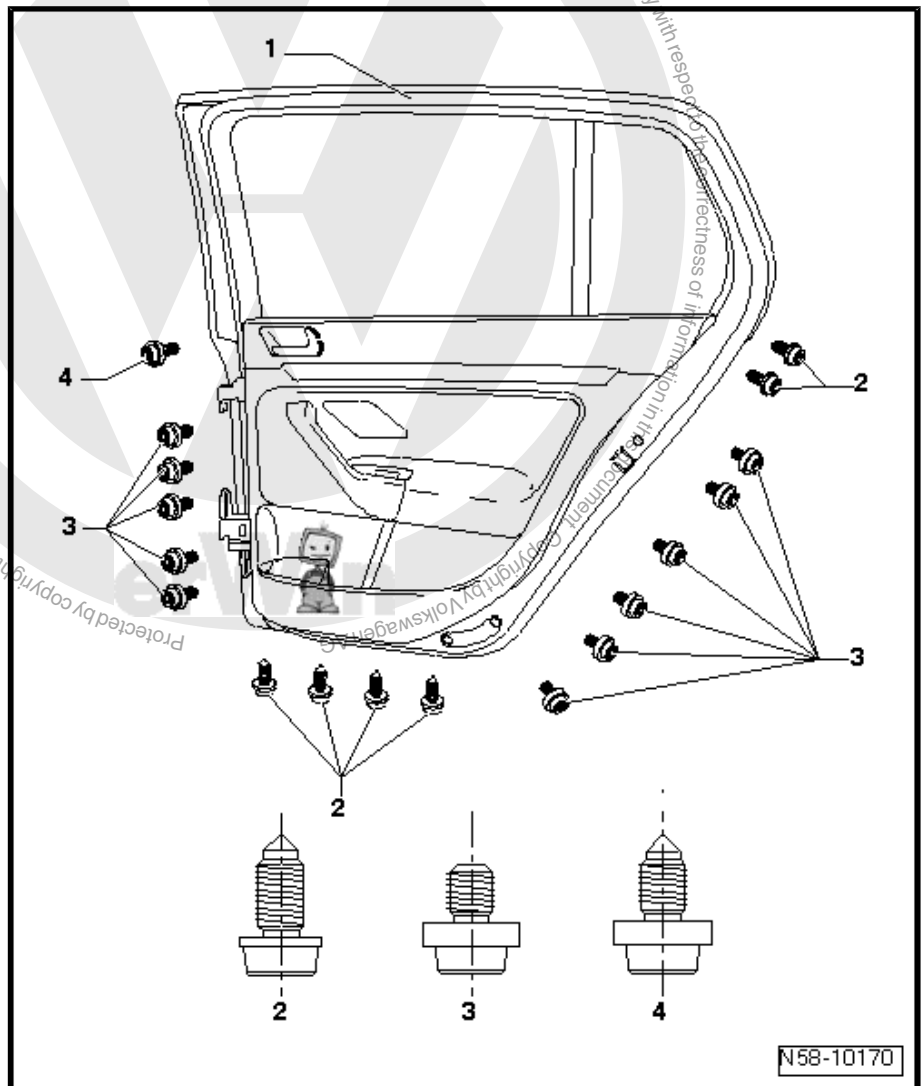
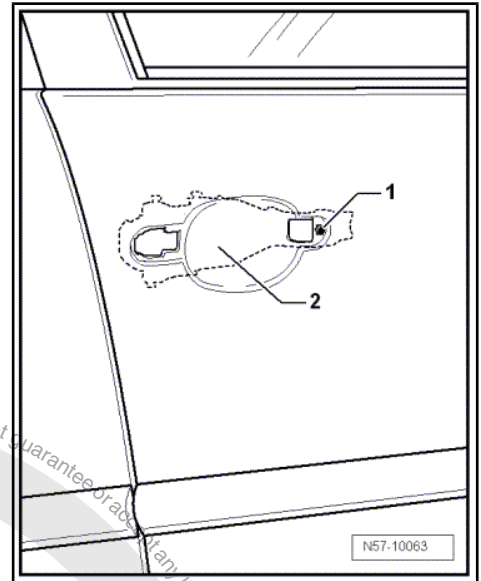

- Remove all bolts -2, 3 and 4-.
- Carefully remove door outer panel.



1.7.2 Installing



Caution

Bolts of different types are used to secure door outer panel. If these are fitted in the wrong positions, the door outer skin will be damaged.

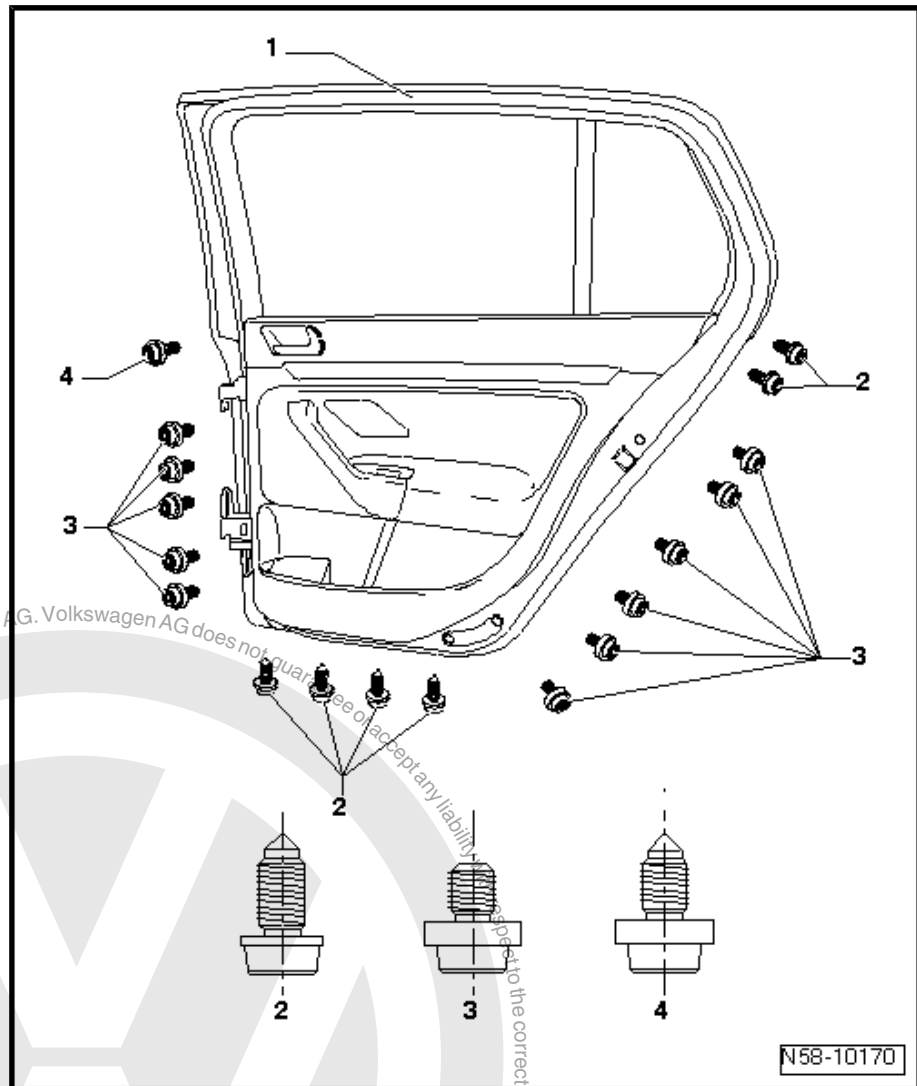

Carefully fit door outer panel.

- Insert all bolts -2, 3 and 4-.
- Observe correct usage for the different types of bolts.
- ◆ Feature for bolt -2-: bolt with pointed end and thin washer.
- ◆ Feature for bolt -3-: bolt without pointed end but with thick washer.
- ◆ Feature for bolt -4-: bolt with pointed end and thick washer.
- Check whether the securing strut guide pins are located in the appropriate guide holes in door inner part. Then first tighten all bolts -2, 3 and 4-.



- Observe correct specified torque for the different types of bolts.

Specified torque for bolt -2-: 10 Nm.

Specified torque for bolt -3-: 14 Nm.

Specified torque for bolt -4-: 10 Nm.

Further installation is performed in the reverse order of removal.

1.8 Installing new outer panel for door

 **Caution**

Bolts of different types are used to secure door outer panel. If these are fitted in the wrong positions, the door outer skin will be damaged.

 **Note**

Observe section, installation notes for bonding-in a new door outer panel => [page 102](#)

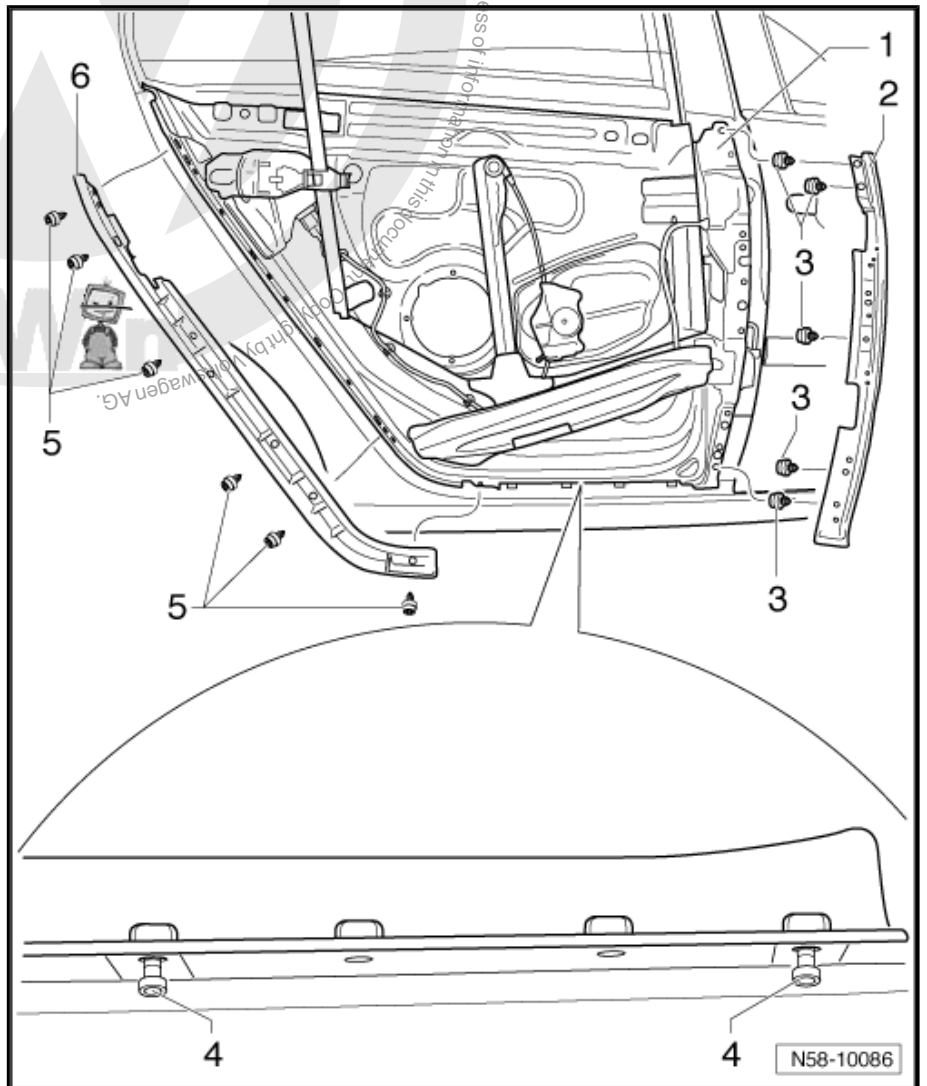



- The old (damaged) door outer panel with retaining rails is removed ⇒ [page 94](#)
- Install front -2- and rear -6- retaining rails to door inner part. For this use "bolt without point with thick washer".

Specified torque for bolts -3- and -5-: 10 Nm.

- Fit two guide bolts in lower edge of door inner part.

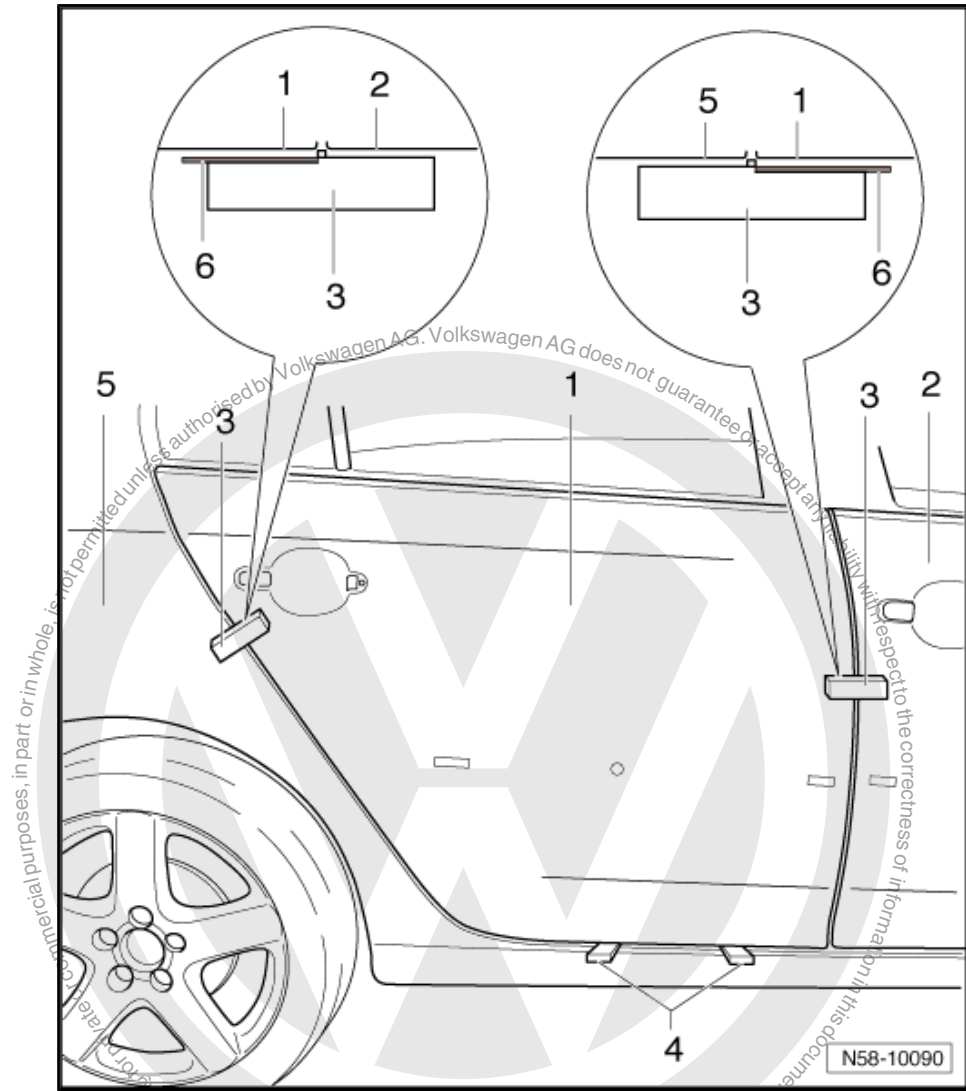

The painted door outer panel is first offered up without bonding agent.

To fit door outer panel, assembly block from assembly tool set -T 10237- is required. A strip of "Tesa Power Strips large" -6- is applied on the lower side. The pin has the minimum dimension for the gap width. The non bonded surface is brought into position with the adjacent component.

- Bond assembly block -3- on door outer panel.
- Guide door outer panel -1- over guide bolts in lower edge of door inner part.
- Adjust gap to side member and door outer panel height using wedges -4- from assembly tool set -T 10237- .



- Place door outer panel with assembly blocks on surrounding components -2 and 5-.
- Check gap dimension using setting gauge -3371- → Body Repairs; Rep. Gr. 00 ; Technical data; Body gap dimensions .
- If gap dimension cannot be adjusted, door inner part must be adjusted ⇒ [page 104](#)
- Remove door outer panel again.

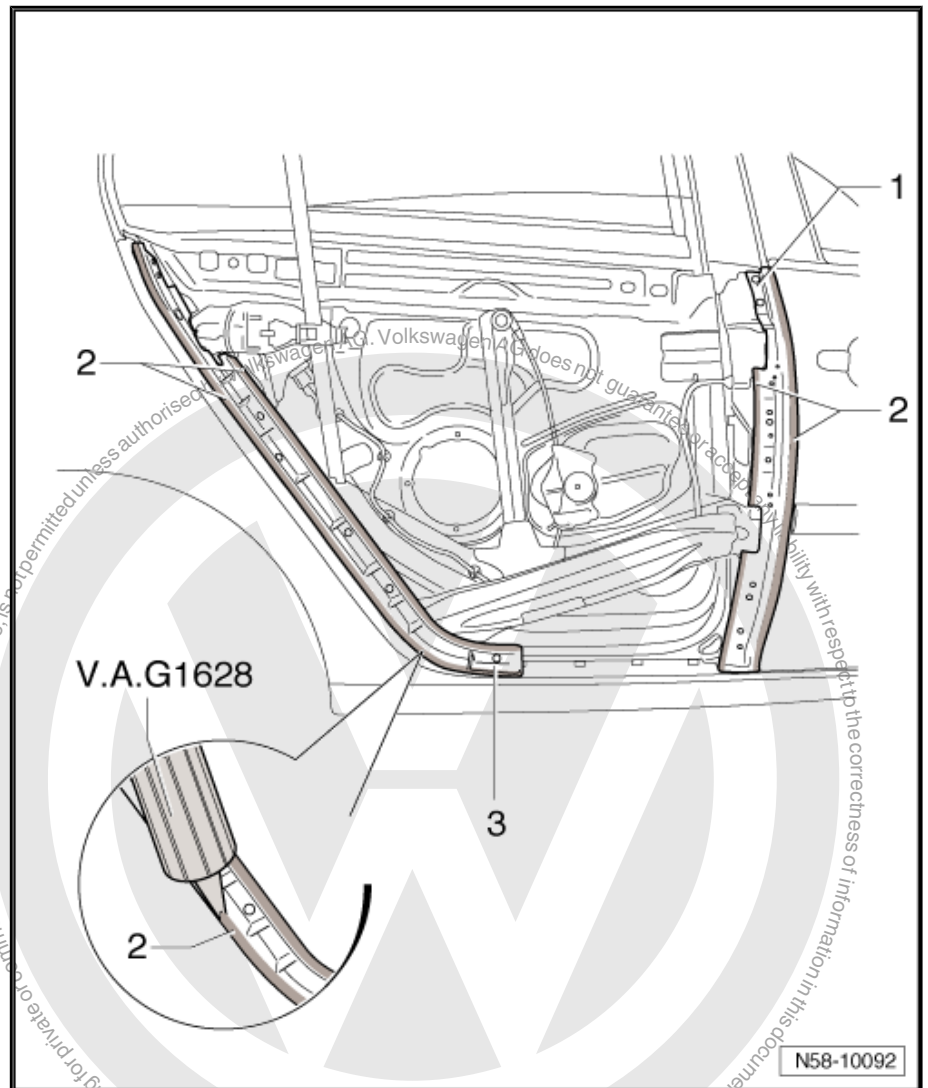

- Apply a bead of adhesive material -2- using cartridge gun - V.A.G 1628- to front -1- and rear -3- retaining rails.

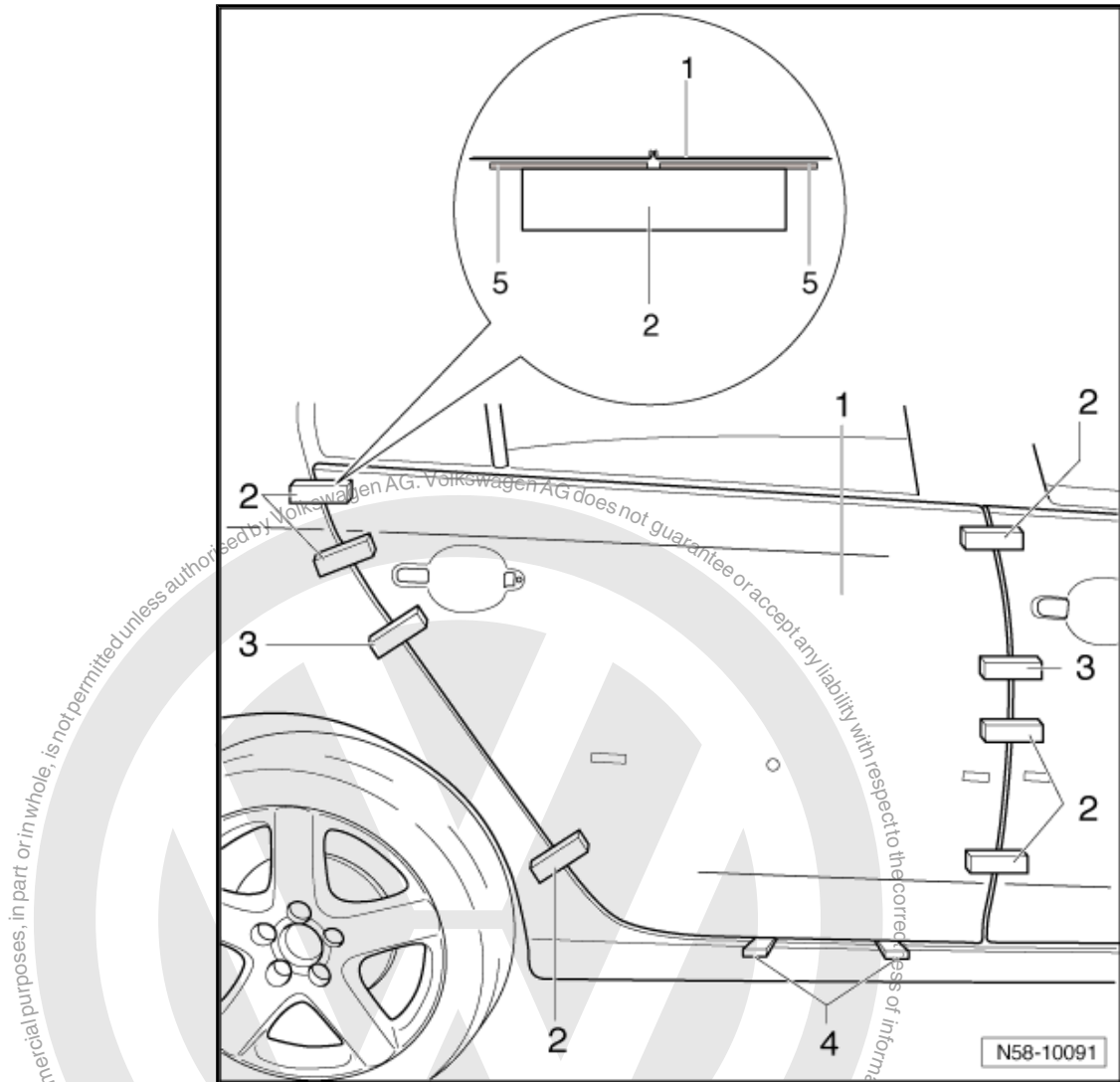

To fit door outer panel, assembly block from assembly tool set - T 10237- is required. Two strips of "Tesa Power Strips large" -5- are bonded to the contact surfaces.

- Guide door outer panel -1- over guide bolts in lower edge of door inner part.
- Place door outer panel with assembly blocks -3- on surrounding components.
- Adjust gap to side member and door outer panel height using wedges -4- from assembly tool set.
- Check gap dimensions using setting gauge -3371- ⇒ Body Repairs; Rep. Gr. 00 ; Technical data; Body gap dimensions .
- Bond short fixing block -2- evenly on the replacement door and the adjacent components.



Note

A curing period of 180 minutes must be observed before performing further work on the door which has been bonded.

- Further installation is performed in the reverse order of removal ⇒ [page 96](#) .



1.9 Removing and installing retaining rail on door outer panel

1.9.1 Removing retaining rail



Caution

The following work steps are to be carried out with great care. As door outer skin is to be reused, dents and scratches must be avoided.

When cutting through the adhesive bead, always hold the retaining rail and door outer skin together as shown in the illustration. If this is not done, the door outer skin will come away from the retaining rail, thus rendering it useless.



Note

The following work steps should be carried out with the aid of an assistant.

Door outer panel with retaining rail is removed → [page 94](#)

- Place door outer panel -1- on firm surface and protect door outer panel against scratches.
- Fit reel device -2- in place.
- Secure cord -5- on reel device and counterhold -4-.

Hold retaining rail and outer skin together securely when cutting through adhesive bead.

- Cut through adhesive bead of retaining rail -3- and door outer panel -1- with cord up to just over half way.

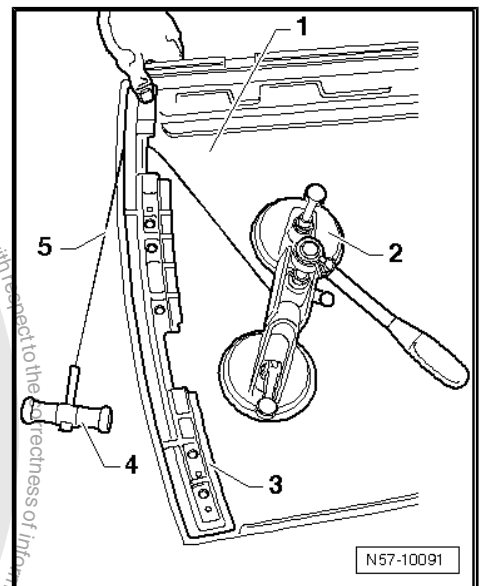



- Once adhesive bead has been cut through to just over half way in step one, turn reel device -2- around and insert cord -5- in side still bonded.
- Hold retaining rail -3- and outer skin -1- together securely when cutting through adhesive bead further.
- Cut through second half of adhesive bead.

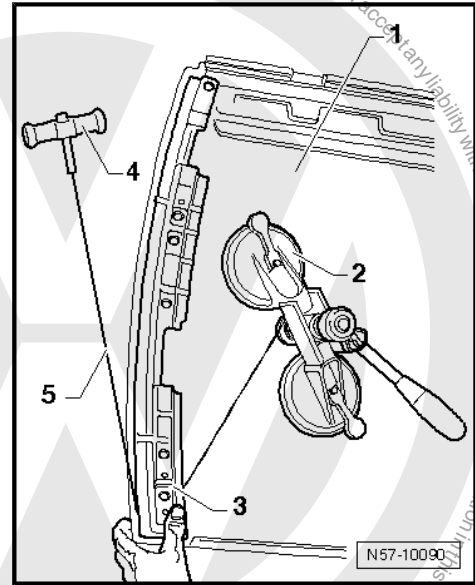

1.9.2 Installing retaining rail

- Cut away remainder of adhesive bead to a minimum on outer panel with the greatest of care, ensuring that no damage is caused to the paintwork.
- Remainder of work procedure is described in chapter entitled "Installing new door outer panel" => [page 58](#)



Note

Observe also "instructions for bonding in new door outer panel" when installing a new retaining rail.

- In place of removed retaining rail, install a new retaining rail on the door inner panel.
- Apply adhesive to new retaining rail.
- Tighten screws to secure door panel on lower edge and on retaining rail still in place.
- Secure door outer panel on new retaining rail with fixing blocks.

1.10 Installation instructions for bonding in new door outer panel



Note

- ◆ If both door outer panels on one side have to be renewed, the sequence must be observed. The rear door outer panel is aligned and bonded in first, followed immediately by the front door outer panel. The long fixing blocks must be bonded in from the rear door outer panel to the front door outer panel.
- ◆ If the door outer panel CDP coating is damaged on inside in bonding area, or if this area has paint on it, this area must be primed with glass/paint primer D 009 200 02.
- ◆ The 1K window adhesive DH 009 100 must be heated in cartridge heater -V.A.G 1939 A- for 20 minutes.



- Apply adhesive material to appropriate surfaces at right angles to retaining rail using cartridge gun -V.A.G 1628- .

**WARNING**

Door outer panel must be installed within 10 minutes, or adhesive properties of adhesive will be impaired.

- ◆ With assistance of both assembly blocks, place door outer panel on retaining rails, align with wedges and setting gauge -3371- and press contact surfaces of assembly blocks onto surrounding components.
- ◆ Secure door with fixing blocks during curing time.
- ◆ After installation door outer panel must align with other components and gap dimension must be even.
- ◆ If adhesive bead is too thick and adhesive swells out between retaining rail and door outer panel, excess adhesive must be removed.

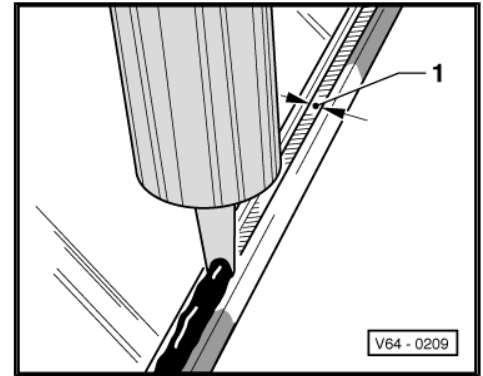

1.11 Minimum curing period

**WARNING**

Special standards must be adhered to when replacing bonded door outer panels. One of these standards is, for example, that a freshly bonded door outer panel must comply with the safety requirements, even in an accident, following the minimum specified curing time.

For 1K adhesive DH 009 100 minimum curing time for door outer panel is 180 minutes.

Minimum curing time means the time from bonding-in the door outer panel to the time the vehicle is brought into use or further work is carried out. During this time, the vehicle must stand on a level surface at room temperature (at least 15 °C).

**WARNING**

Vehicle is safe to use only after the minimum curing period is completed.

1.12 Cleaning off excess adhesive sealing material

- Adhesive remover D 002 000 10 must be used as cleaning agent. Observe the appropriate safety precautions when performing this work.

**WARNING**

When cleaning vehicle, the door outer panel just bonded-in must not be moved.

- First clean painted surface as much as possible using a dry cloth. Remove remaining adhesive with adhesive remover D 002 000 10.



- Cleaning plastic trim: allow adhesive sealant to cure (approx. one hour) and then peel off.

1.13 Assembly overview - door inner part



Note

The right side is shown. The left side is similar.

1 - Window slot seal

2 - Insulation

- Qty. 4
- 20 mm x 40 mm, commercially available textile adhesive tape.

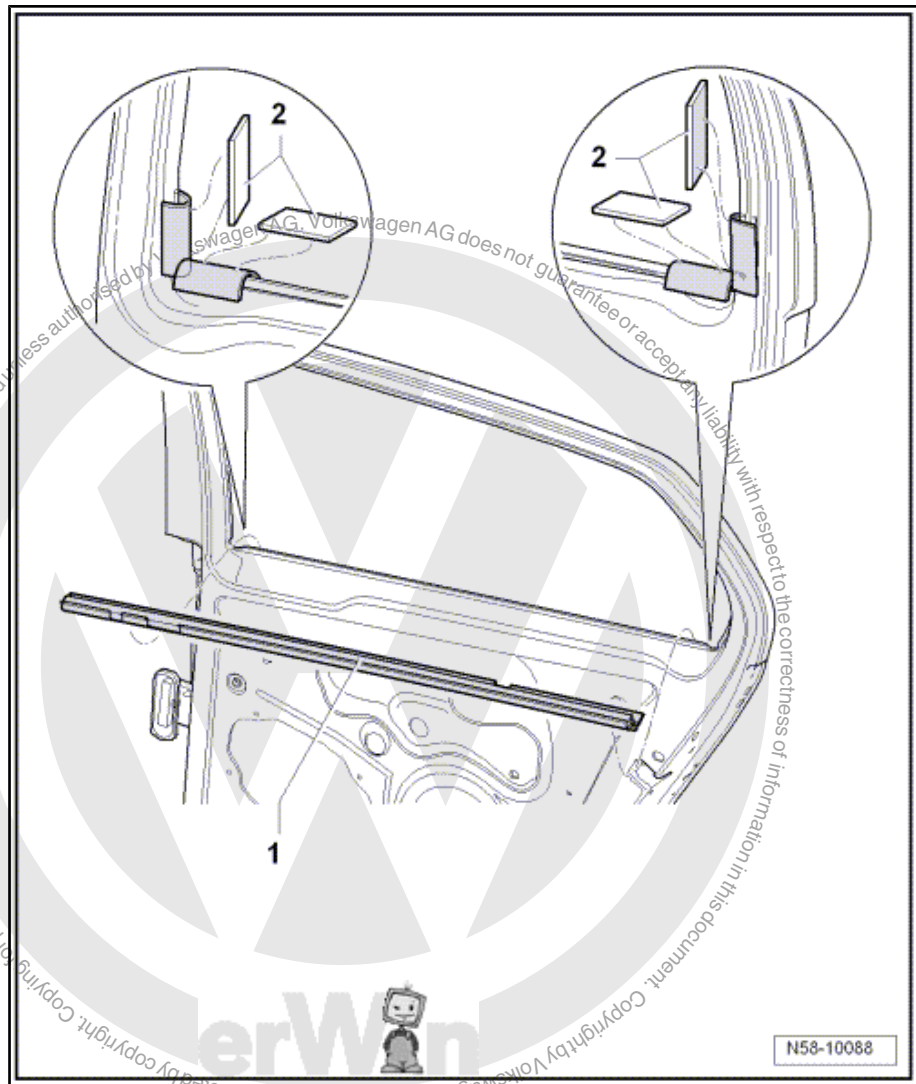



1.14 Assembly overview - door handle and door lock

Note

The right side is shown. The left side is similar.

1 - Door lock

- Door lock can only be removed together with door outer panel
- Removing and installing ⇒ [page 110](#)

2 - Retaining bracket

- Not installed on Golf

3 - Spreader rivet

- Not installed on Golf

4 - Cable

- To release lock from inner door handle

5 - Cover

- Not supplied as part of door lock
- Secured to door lock with three locking lugs

6 - Bearing plate

- Removing ⇒ [page 108](#)

7 - Bolt

8 - Base

- Part of door handle

9 - Door handle with base

- Removing and installing ⇒ [page 106](#)

10 - Cover

- For lock cylinder housing with no opening for lock cylinder
- Secured to lock cylinder housing with three locking lugs

11 - Housing

- Removing and installing ⇒ [page 106](#)
- Without cylinder lock

12 - Base

13 - Torx screw

- Socket -T 10072-
- Loosening this screw releases the lock cylinder housing ⇒ [Item 11 \(page 105\)](#), which can then be pulled out of the bearing plate

14 - Bolt

- 18 Nm

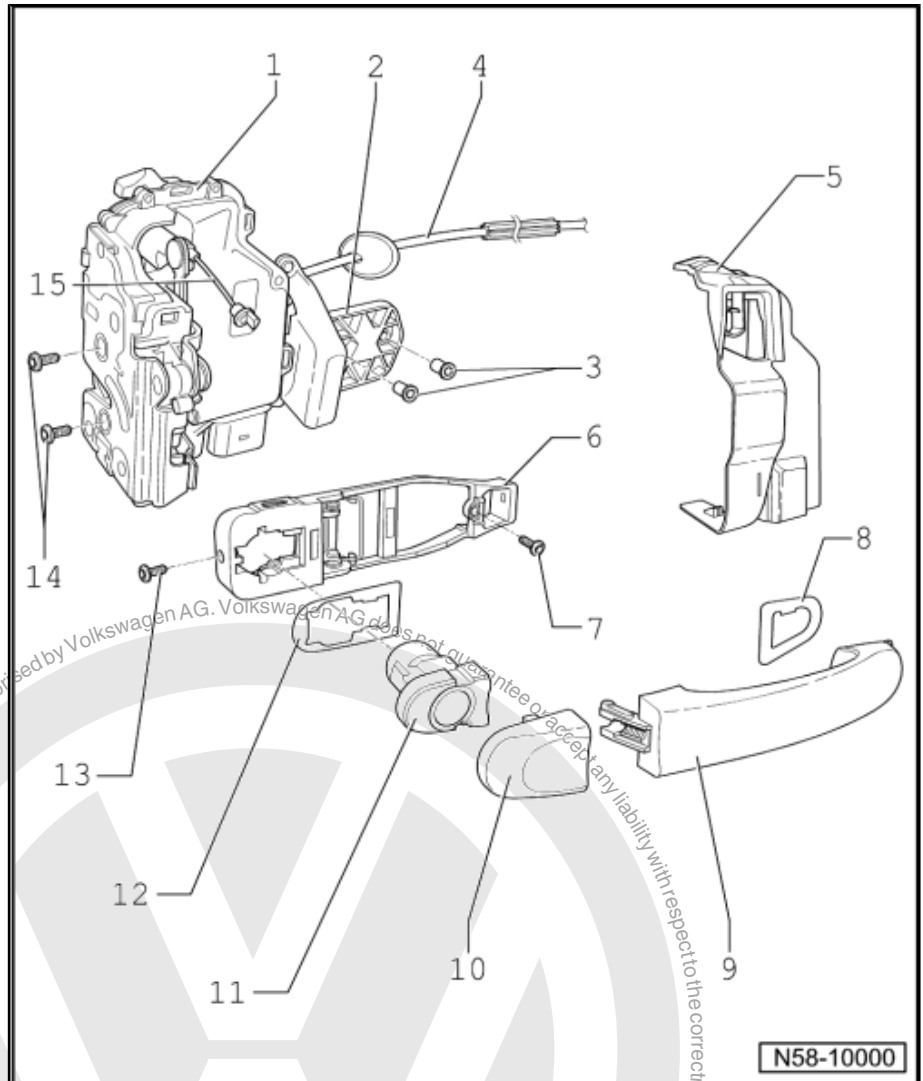



15 - Cable

- To release lock from outer door handle

1.15 Removing and installing housing



Note

Removal and installation sequence is only for right housing. Removal and installation of left housing is similar.

1.15.1 Removing

- Lever out caps in front of bolts -1-.
- Pull door handle -2- in -direction of arrow- and unscrew bolt -1- using socket wrench -T 10072- until housing -3- can be pulled out.
- Pull housing -3- out of door handle mounting bracket at right angles to door.

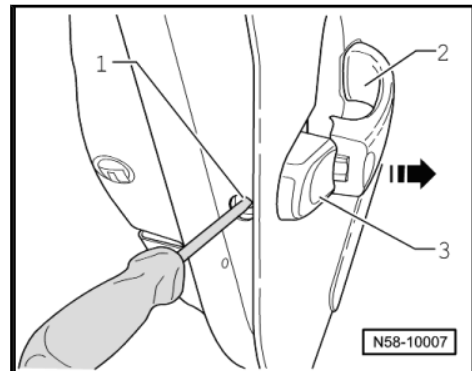

1.15.2 Installing

- Fit housing -2- into door handle mounting bracket at right angles.

Door handle -1- must rest only lightly against door panel.

- Now tighten bolt -3- in bearing plate using socket -T 10072- .

The door handle engages in the lock cylinder housing with an audible click.

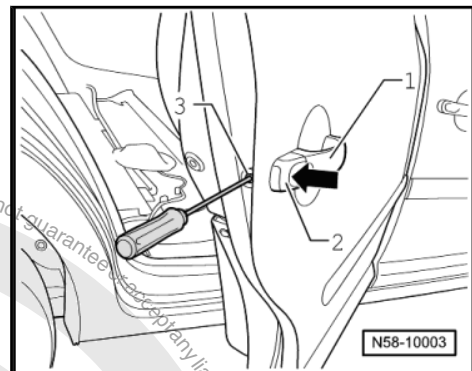

Note

During installation, housing must be pressed against door panel. Door handle rests only lightly against door panel.

- Then perform remaining installation in reverse order of removal.
- Then always check function while door is still open, as an incorrectly fitted and adjusted Bowden cable cannot open the door.

1.16 Removing and installing door handle



Note

The removal and installation sequence is only for the right door handle. The removal and installation of the left door handle is similar.



1.16.1 Removing

- Remove housing => [page 106](#) .
- Lever clip -2- out of door handle -1-.
- Swivel door handle -1- out of door -arrow-.

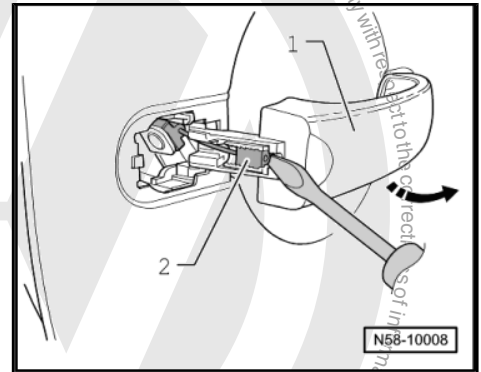

1.16.2 Installing

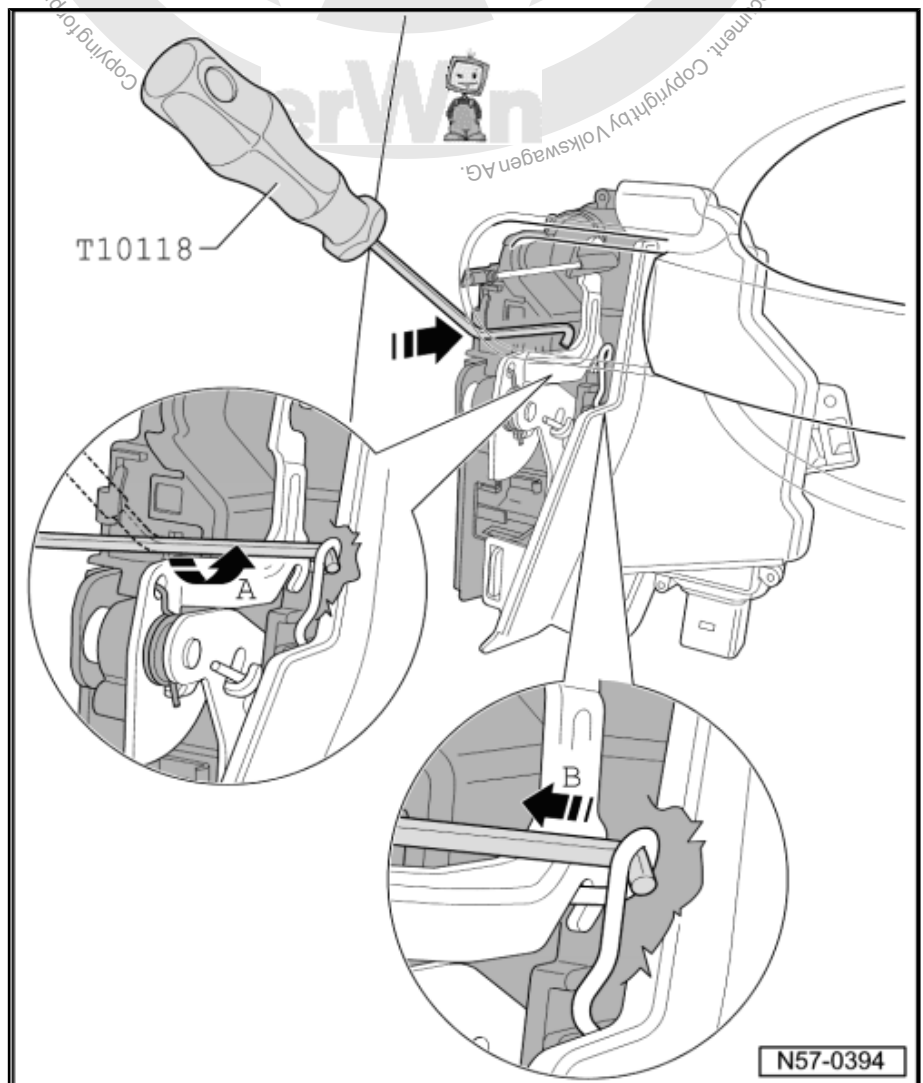

- Guide assembly tool -T 10118- into door through opening in door inner panel.
- Use a hand torch to illuminate inside of door for improved visibility.
- Hook assembly tool -T 10118- in spring -arrow A-.



- Hook spring into door lock by pulling assembly tool -T 10118-
-arrow B-.

The release lever is now secured.

- Swivel door handle -1- into door.
- Pull clip -2- in the panel opening and engage clip in door handle -1- -arrow-.



Note

- ◆ Door handle -2- must be pressed against door panel when assembling.
- ◆ Clip -2- must engage in door handle -1- with a clearly audible click.

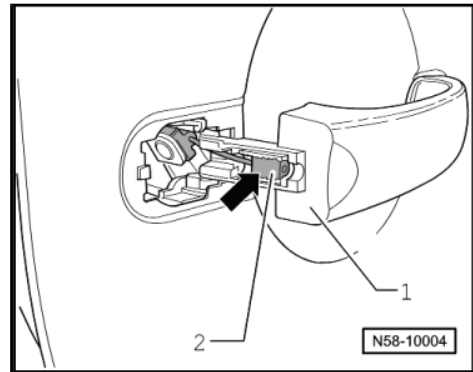

Installing housing ⇒ [page 106](#)

- Then always check function while door is still open, as an incorrectly fitted and adjusted Bowden cable cannot open the door.

1.17 Removing bearing bracket



Note

Removal and installation are described only for the right bearing bracket. The removal and installation of left mounting plate is similar.



1.17.1 Removing

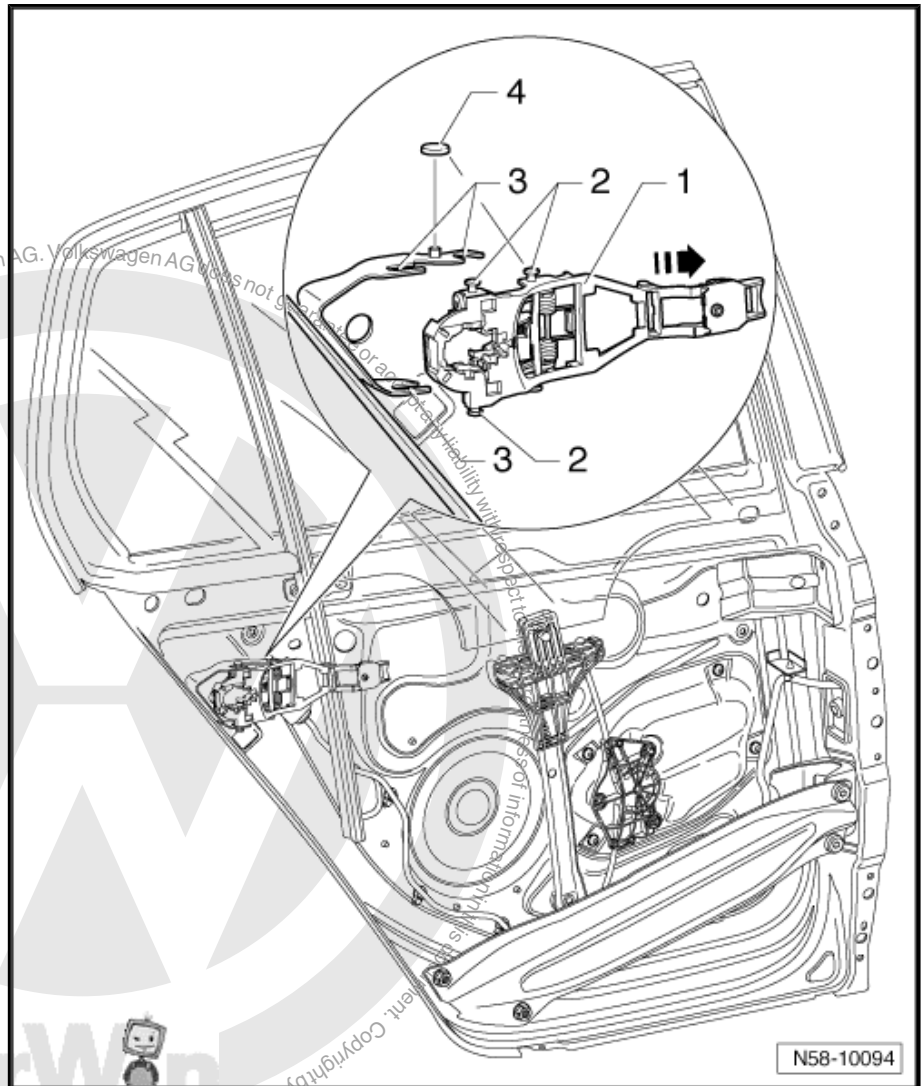

- Remove housing ⇒ [page 106](#)
- Remove door handle: ⇒ [page 106](#) .
- Remove door outer panel: ⇒ [page 94](#)
- Pull retaining rubber -4- off upwards from guide pins and retaining pins on mounting.
- Pull mounting plate -1- with guide pins -2- out of mounting -3-.



1.17.2 Installing

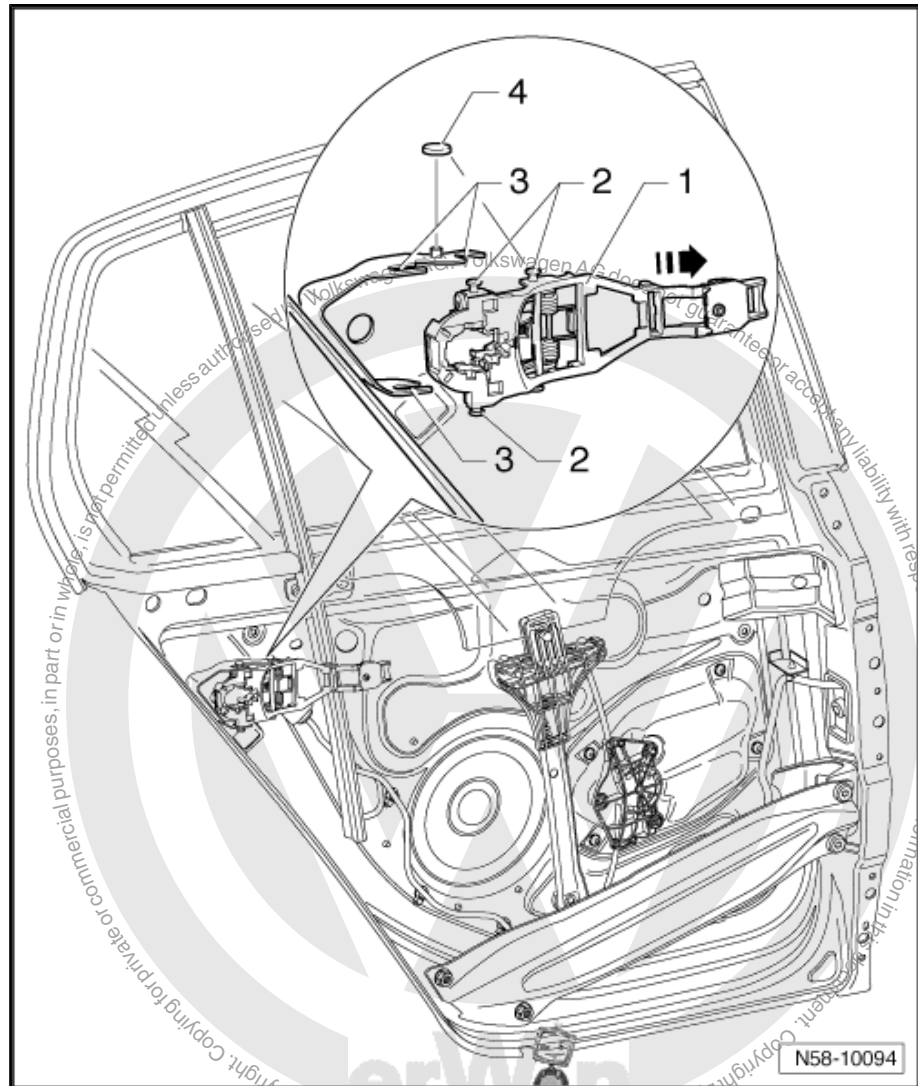

- Push mounting plate -1- with guide pins -2- in mounting -3-.
- Secure retaining rubber -4- to guide pins and securing pins on mounting.

1.18 Removing and installing door lock



Note

The removal and installation sequence is only for the right door lock. The removal and installation of the left door lock is similar.



1.18.1 Removing

- Remove door outer panel ⇒ [page 94](#) .
- Remove mounting plate ⇒ [page 108](#) .
- Separate connector -4-.
- Remove bolts -6-.
- Release cable -3- from relay lever -5- and remove door lock -1-.

Cover -2- is not supplied with door lock.

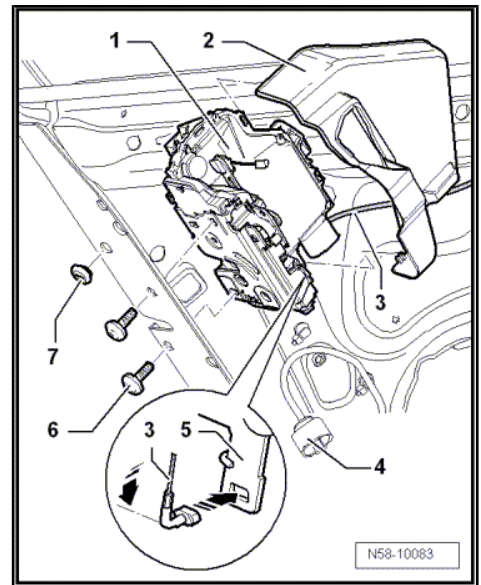

1.18.2 Installing

Installation is carried out in reverse order of removal.

Specified torque for bolts: 18 Nm.

- Then always check function while door is still open, as an incorrectly fitted and adjusted Bowden cable cannot open the door.

1.19 Assembly overview - side impact protection



Caution

The nuts and bolts of the side impact protection are also painted in the factory. This means that a great deal of force is required to remove them, resulting in some circumstances in the threads shearing. If possible avoid loosening the nuts and bolts.



1 - Side impact protection

2 - Bolts

- Qty. 2
- 20 Nm

3 - Nut

- Qty. 2
- 20 Nm

4 - Door inner part

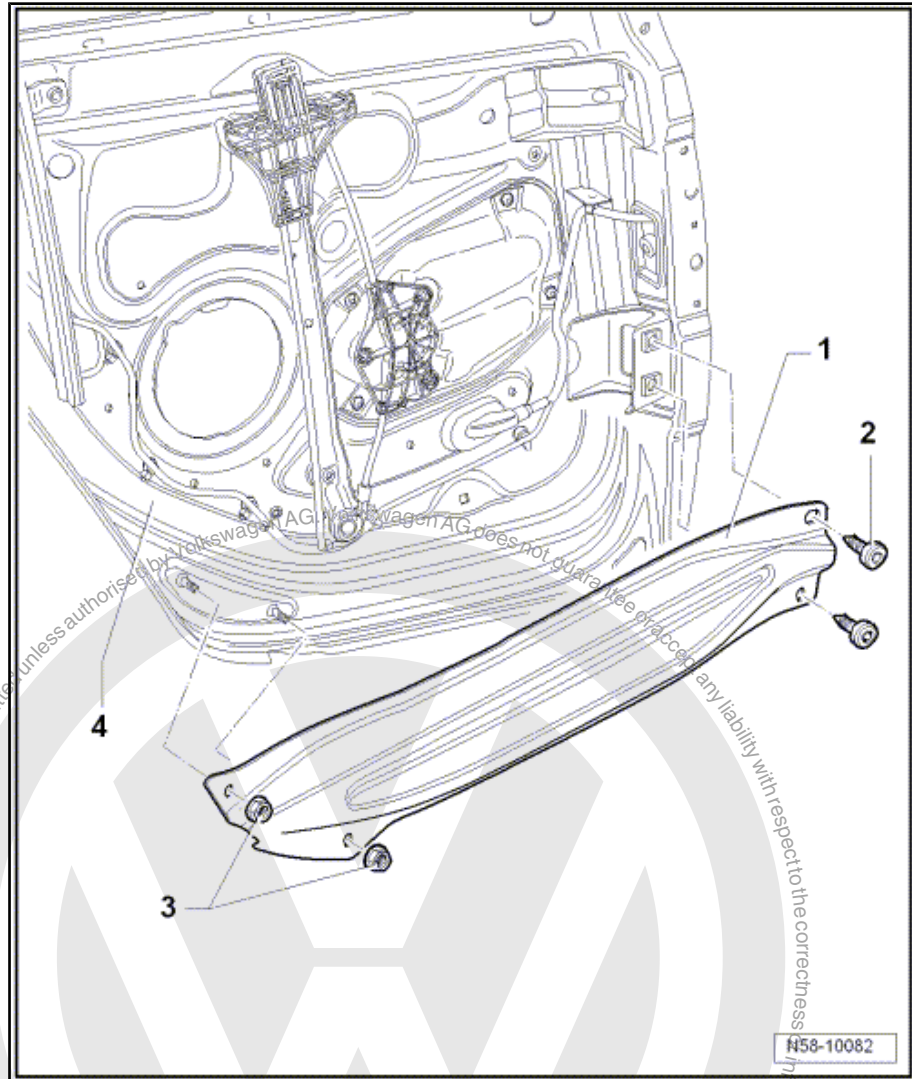

1.20 Door inner seals

During production, a sealant is applied to the door inner seals, which are then placed on the door flange and rolled on.



Note

- ◆ *When seals are removed, the sealant will spread to the inside of the seal and the flanks will be bent out slightly. If the seal is then refitted, a tight seal is not guaranteed.*
- ◆ *Therefore each seal which is removed completely should be replaced by a so-called "tap-on" seal.*
- ◆ *If a seal has been partially removed, squeeze sides of seal together before installing.*



1.21 Removing and installing door inner seal



The removal and installation sequence is only for the right door inner seal. The removal and installation of the left door inner seal is similar.

1.21.1 Removing

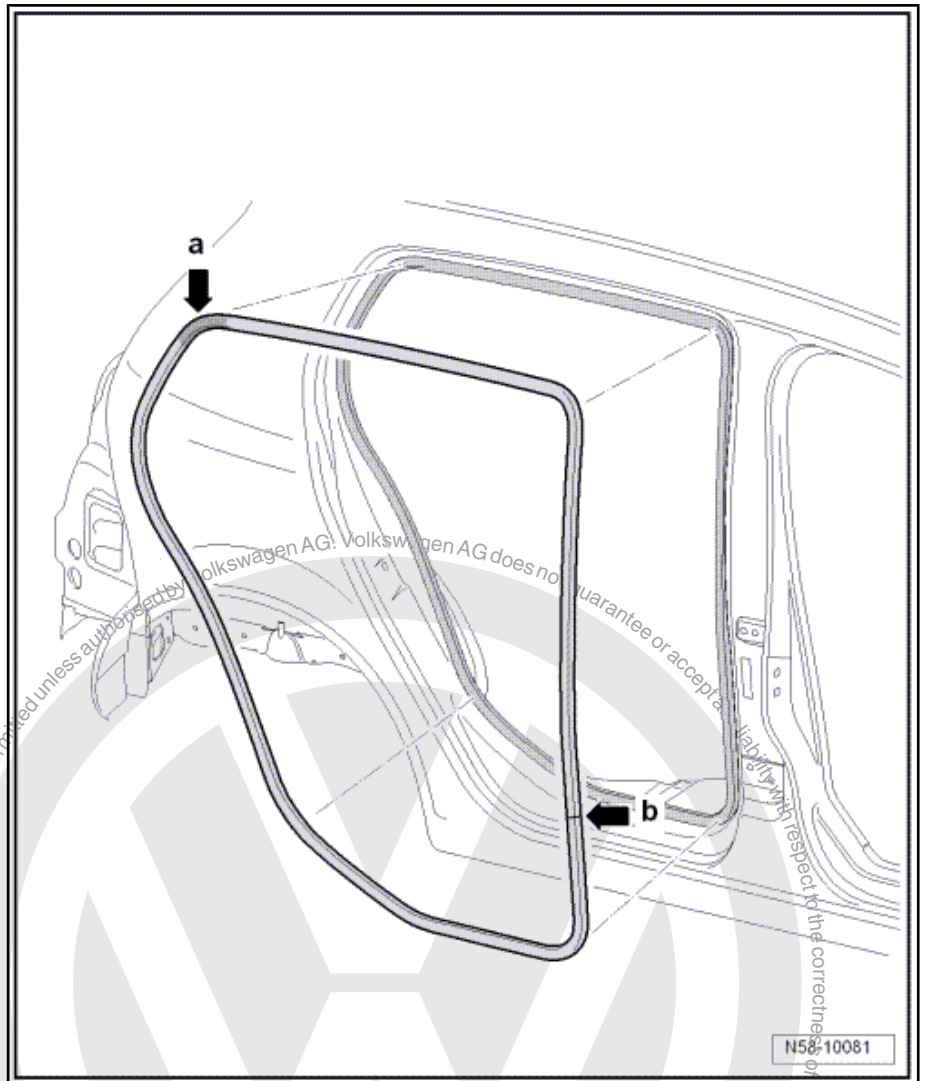

- Pull door inner seal off body flange.



1.21.2 Installing

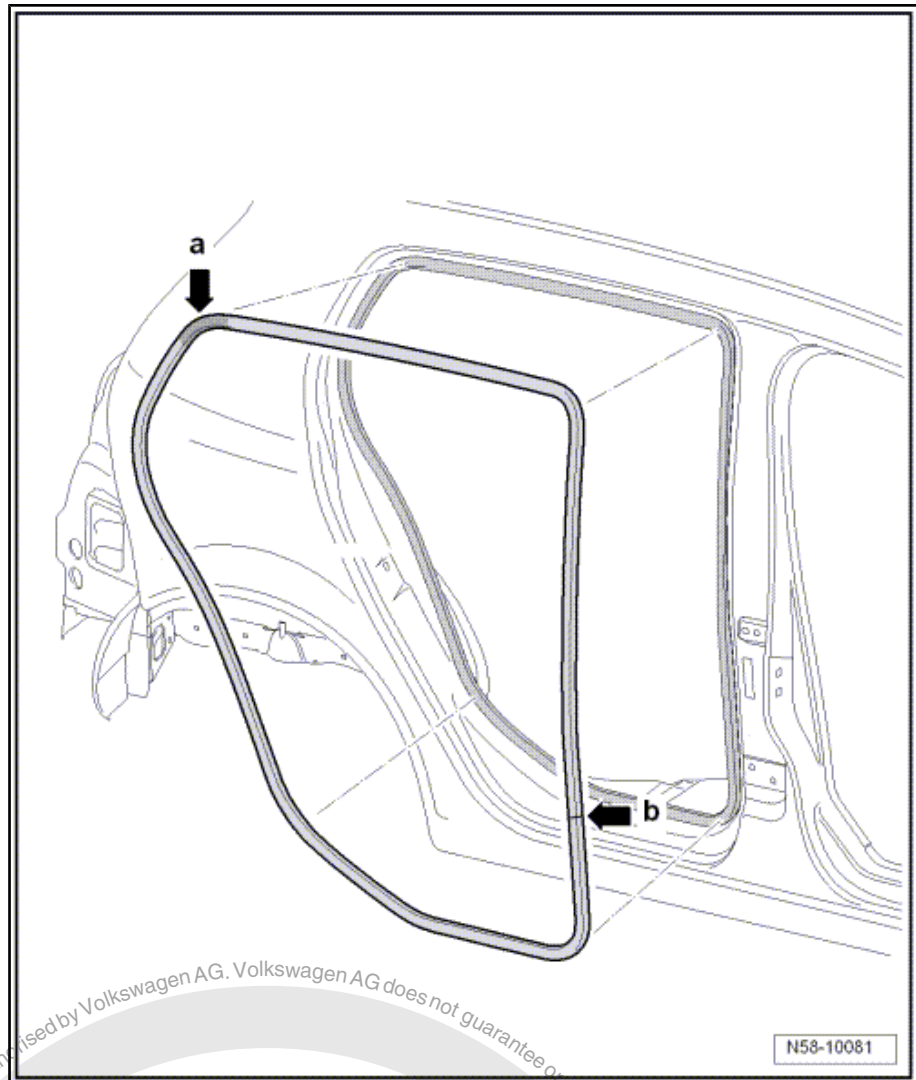

- Align door inner seal with vulcanisation point -arrow b- to height of lower hinge.
- Begin installing door inner seal in upper radius -arrow a- of door aperture.

1.22 Removing and installing door outer seal



Note

- ◆ Removal and installation are described for the right door outer seal only. Removal and installation of the left door outer seal are similar.
- ◆ Remove protective backing immediately before installation. Working temperature approx. 20 °C.
- ◆ Adhesive remover D 002 000 10 must be used exclusively.
- ◆ The door outer seal must be bonded in place immediately after cleaning.



1.22.1 Removing

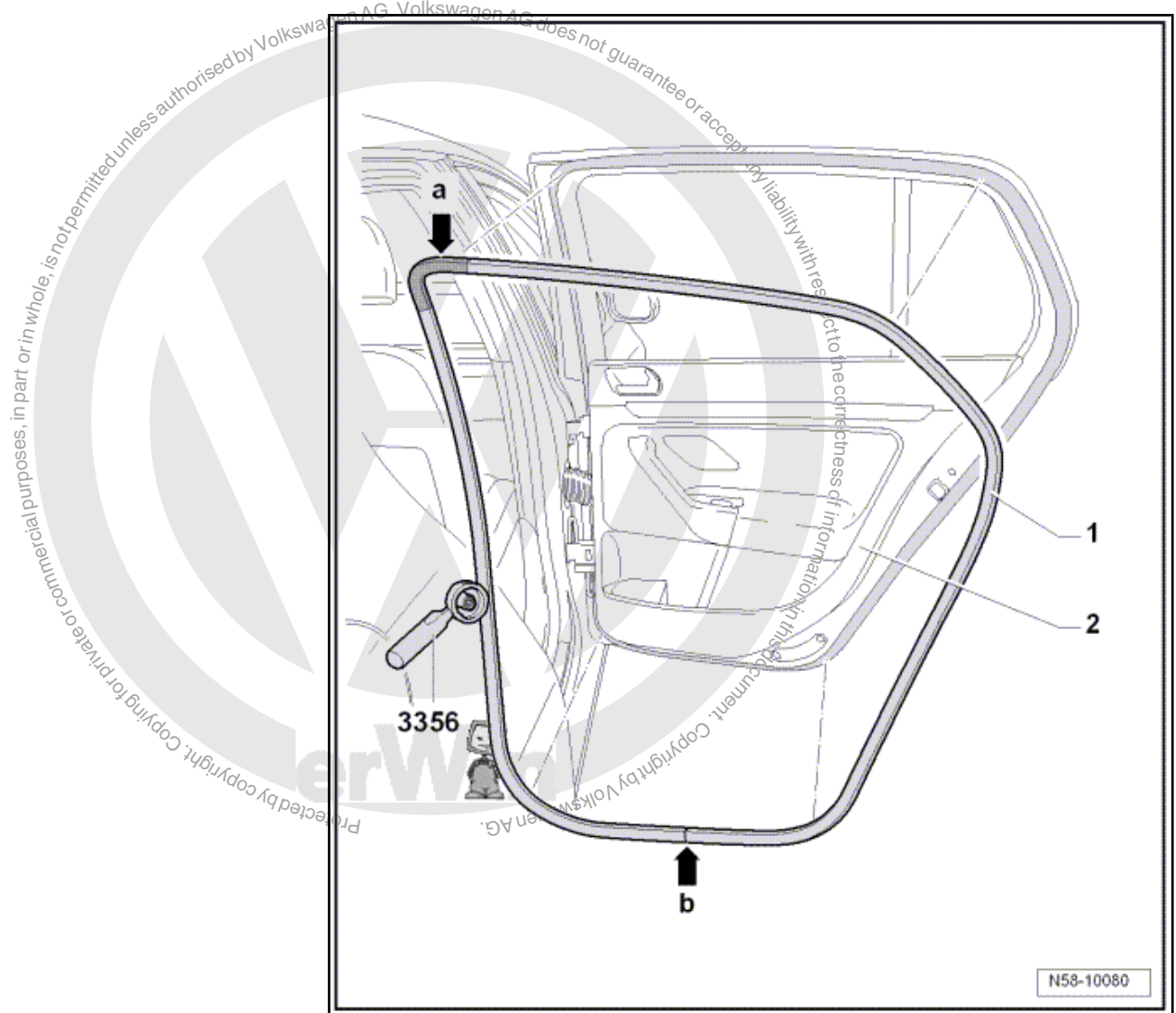

- Pull door outer seal -1- from door -2-.



1.2.2.2 Installing

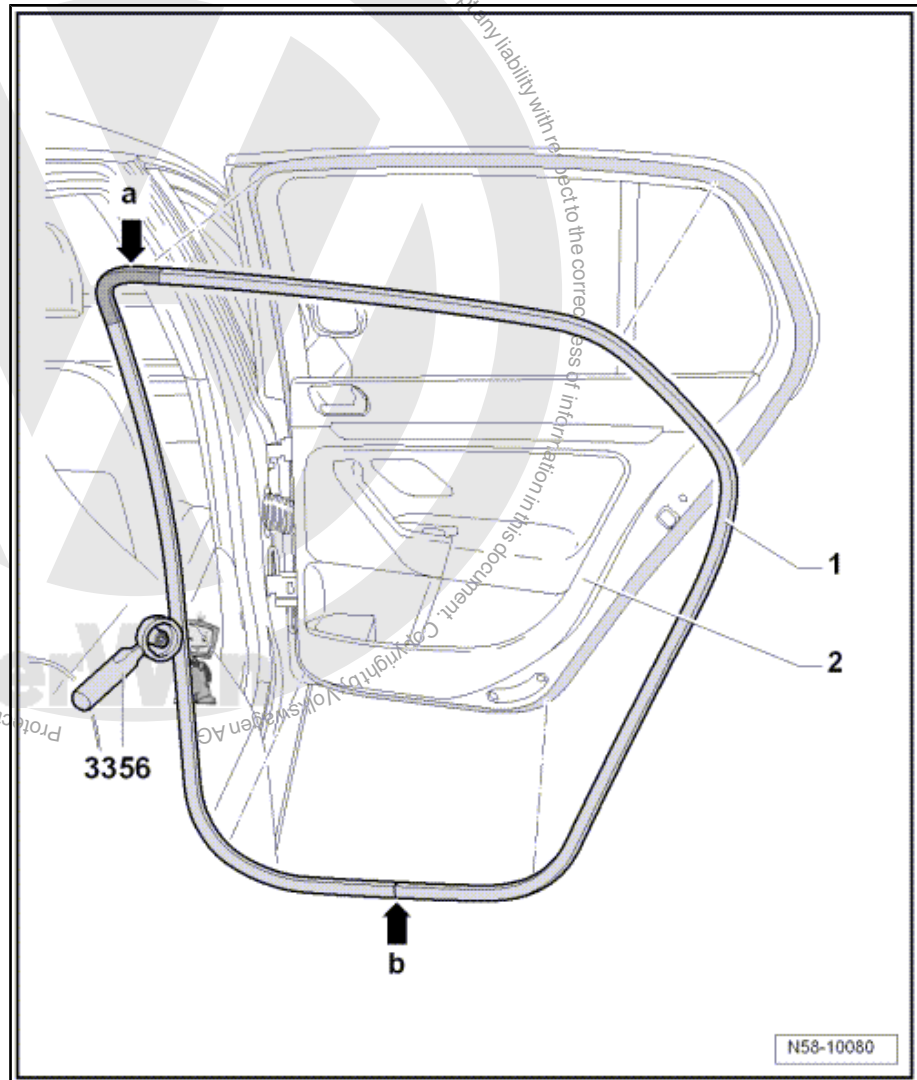

- Remove existing adhesive residues with adhesive remains remover -VAS 6349- .
- Immediately before bonding the door outer seal, clean bonding surface thoroughly with adhesive remover D 002 000 10.
- Surfaces to be bonded must be free of dust and grease and there should be no adhesive residue.
- The vulcanised point -arrow b- of outer door seal -1- must be located in centre of side member.
- Pull protective backing off in stages and start fitting seal in upper radius -arrow a- of door. Do not pull outer door seal to avoid stretching seal.

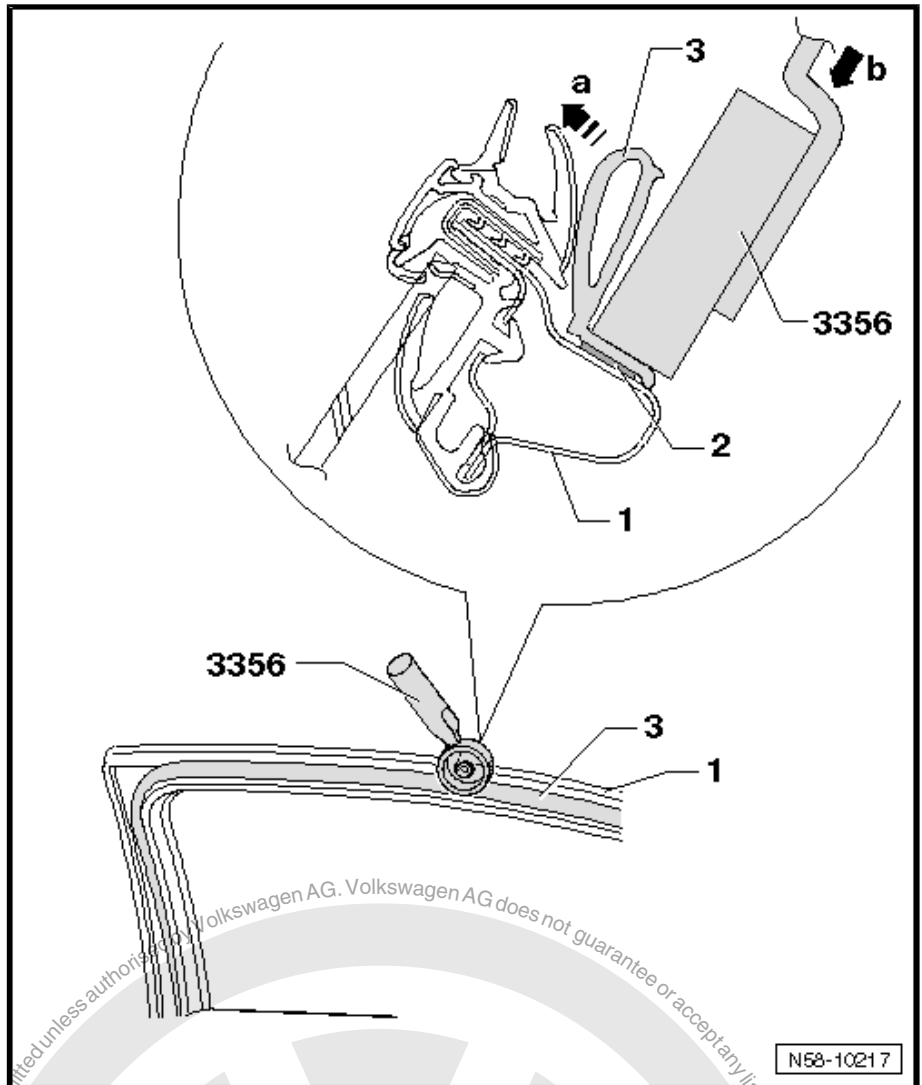

- Press complete adhesive area of seal -3- on door -1- all around using roller -3356- .
- The seal is pushed aside -arrow a- when doing this so that the roller -3356- runs directly over the contact surface of the seal.

The roller can only apply the necessary force -arrow B- to the adhesive surface -2- when procedure described above is followed correctly.

- If the seal is too long: cut seal to required length and press butt joints on well.
- If the seal -3- comes loose in small areas again, press seal on well again using roller -3356- .

i Note

The door must not be closed for a period of 2 hours to ensure the door outer seal does not move or loosen again.



60 – Sunroof

1 Sliding/tilting sunroof with glass panel (Meritor)

1.1 Tools

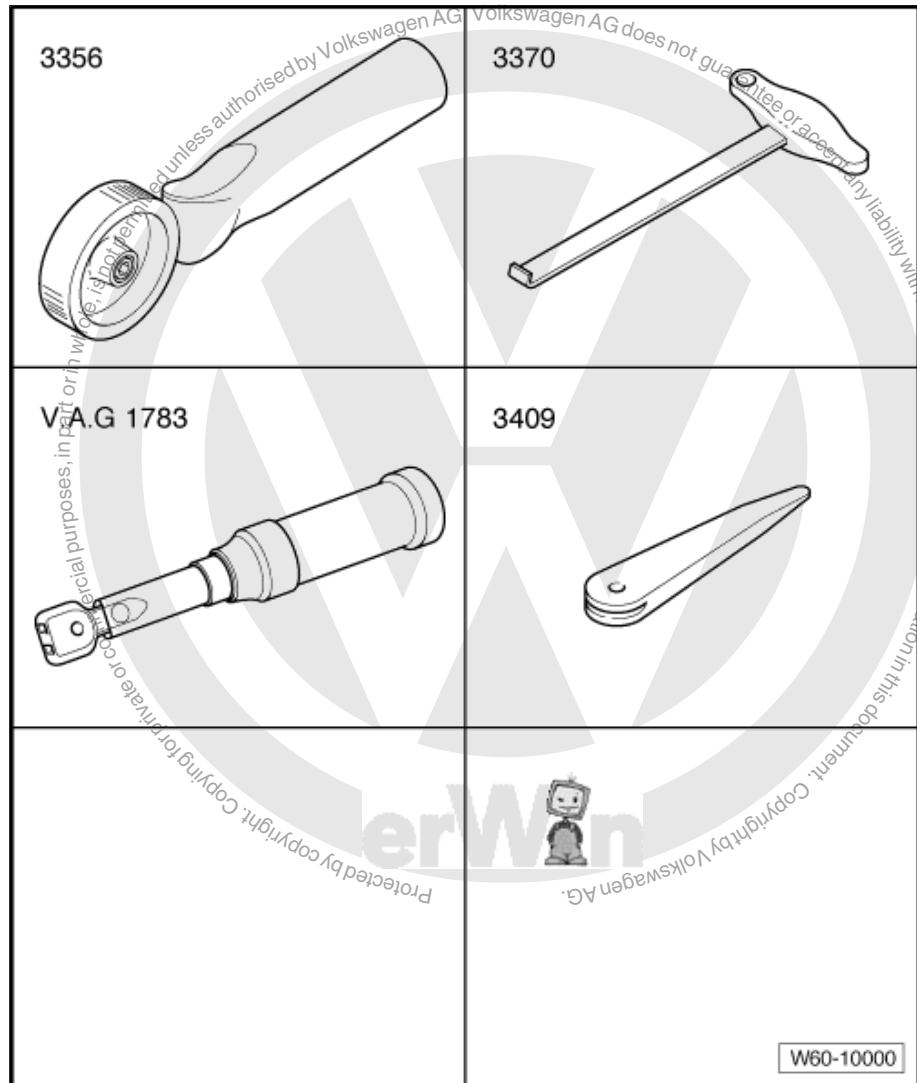

1.1.1 Required special tools, workshop equipment, test and measuring devices and auxiliary items

- ◆ Roller -3356-
- ◆ Hooks for front end -3370-
- ◆ Torque wrench 2...10 Nm -V.A.G 1783-
- ◆ Wedge -3409-



1.2 Function

All actions of the sunroof with glass panel can be performed with the ignition switched on.

After the ignition is switched off, actions can be performed until either the driver or front passenger door is opened.

The opening of the glass panel in sliding or tilting positions can be preselected using the rotary switch.

On the rotary switch there are marks for preset sliding and tilting positions of the glass panel.

Opening sliding/tilting sunroof to the so called comfort position, prevents to a large extent wind noise while driving, which can occur when sunroof is fully open.

Pre-selector switch

The sliding/tilting sunroof with glass panel is equipped with a force limitation (roll back) feature while closing. If an obstacle is encountered during closing or opening from the elevating or sliding position, the glass panel will be moved in the opposite direction.

In addition, there is an emergency closure function. If problems occur during closure, the sliding/tilting sunroof with glass panel can be forced to shut by pressing the preselector switch when it is in the "close sunroof" position.

The roll-back function is disabled when the emergency closure function is active.

The drive for the sliding/tilting sunroof with glass panel is protected against overheating by a time limit. The protective mechanism activates when the sunroof is operated continuously for approx. 2 minutes. It is functional again after a cooling-off phase.

In the event of power failure, the sliding/tilting sunroof with glass panel can be moved using a hexagon key directly on the drive. The hexagon drive can be found in a bracket on the rear of the moulded headliner, next to an opening for the rear lighting unit.

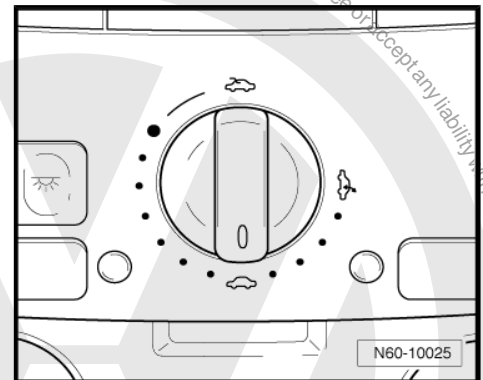



1.3 Assembly overview - sliding/tilting sunroof with glass panel

1 - Glass panel for sliding/tilting sunroof (single pane safety glass)

- Removing glass panel of sliding/tilting sunroof
⇒ [page 123](#)
- Installing glass panel of sliding/tilting sunroof
⇒ [page 124](#)
- Adjusting glass panel of sliding/tilting sunroof
⇒ [page 124](#)

2 - Panel seal

- Adjusting panel seal
⇒ [page 125](#)
- Seal joint positioned in middle of rear area
- Renewing panel seal
⇒ [page 126](#)

3 - Sliding headliner

- Removing and installing sliding headliner
⇒ [page 127](#)

4 - Bolt

- Bolts are microencapsulated and must always be renewed after loosening
- Qty. 4
- 1.8 Nm

5 - Spring slide

- Screwed onto sliding headliner
- Qty. 4
- Can be replaced separately
- Removing ⇒ [page 127](#)

6 - Bellows

- Used to cover guide plate
- Removing ⇒ [page 122](#)
- Installing ⇒ [page 123](#)

7 - Water channel

- Removing ⇒ [page 135](#)

8 - Locking hook guide

- Removed together with guide plate
- Removing ⇒ [page 135](#)

9 - End piece upper part

- Clipped securely onto end piece of lower part
- Removing ⇒ [page 135](#)

10 - End piece lower part

- Can be replaced separately

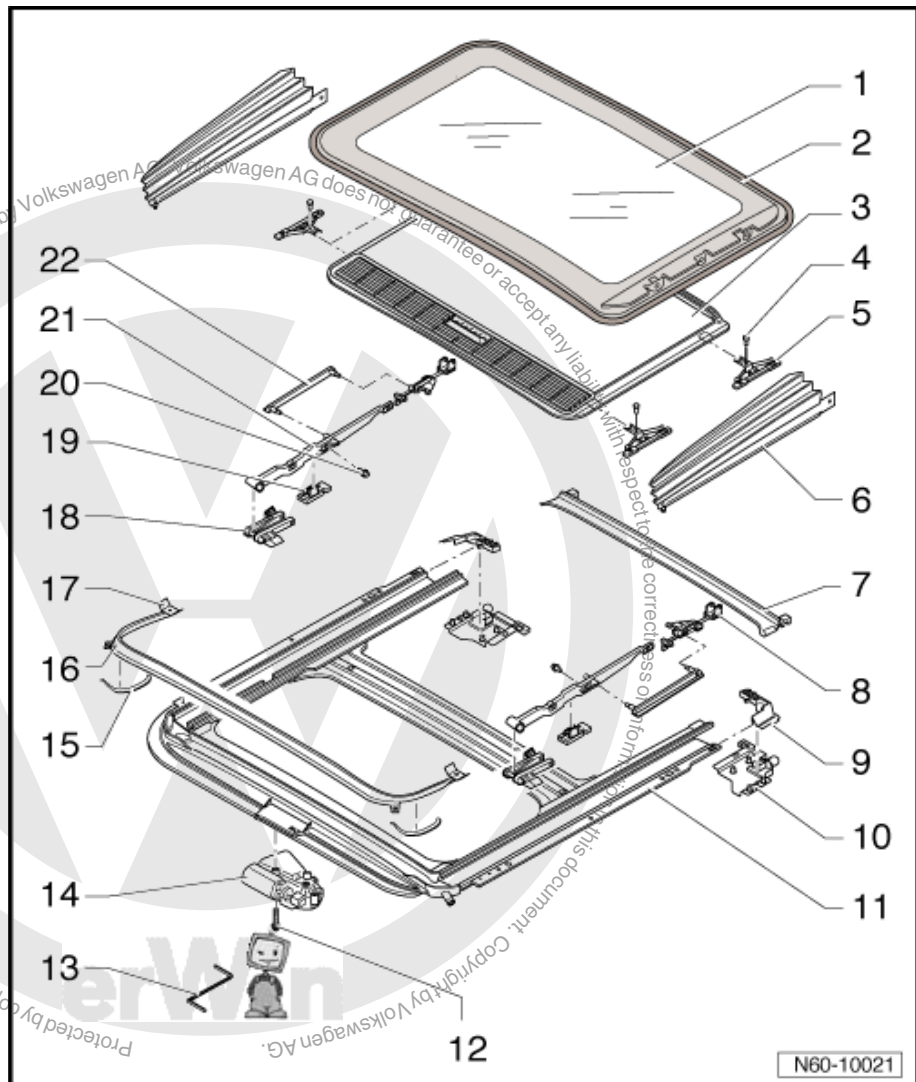



- To seal use butyl adhesive sealing cord -AKL 450 005 05-

11 - Carrier unit

- Removing and installing carrier unit ⇒ [page 132](#)
- If necessary, guide channels should be lubricated only with special grease G 000 450 02, otherwise function may be impaired

12 - Bolt

- Bolts are microencapsulated and must always be renewed after loosening
- Qty. 3
- 3.5 Nm

13 - Hexagon key for emergency operation

- The hexagon key to operate the system in an emergency has been discontinued. Use a commercially available hexagon key to operate the system in an emergency

14 - Electric drive

- Removing ⇒ [page 128](#)
- Adjusting drive (0 position) ⇒ [page 129](#)

15 - Spring

- Qty. 2
- Pushes up wind deflector
- Is clipped onto wind deflector and can be renewed individually
- Removing ⇒ [page 126](#)

16 - Wind deflector

- Removing ⇒ [page 126](#)
- Adjusting on vehicles as of 08.2005 > ⇒ [page 127](#)
- The adjustable wind deflector cannot be retrofitted

17 - Wind deflector bearing

- Qty. 2
- Is clipped onto wind deflector and can be renewed individually
- Removing ⇒ [page 126](#)

18 - Front guide

- Can be removed separately from the guide rail
- Removing ⇒ [page 135](#)

19 - Lower rear guide

- Removed together with guide plate
- Removing ⇒ [page 135](#)

20 - Torx screw

- Torx T25
- Qty. 3 per side
- 5 Nm

21 - Guide plate

- Removing and installing ⇒ [page 134](#)

22 - Spacer

- Removing and installing ⇒ [page 134](#)



1.4 Removing and installing bellows

1.4.1 Removing

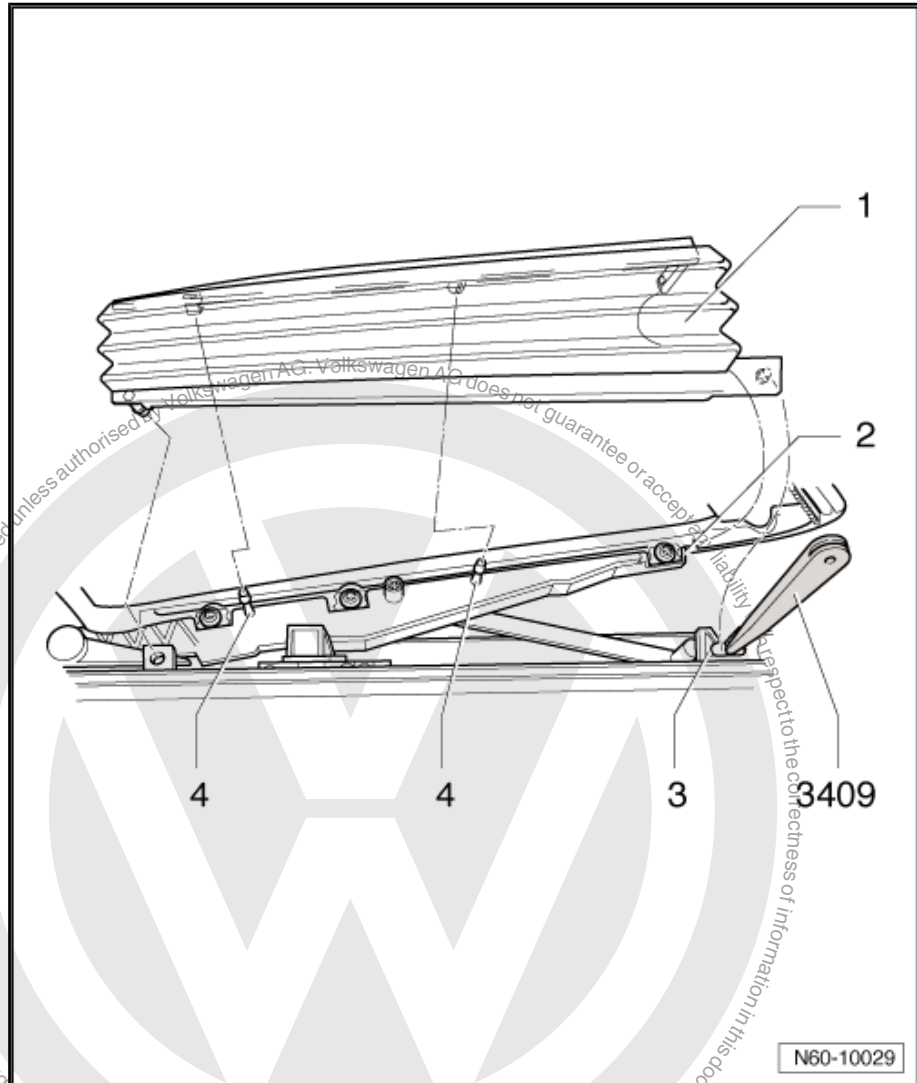

- Move sliding headliner to rear.
- Run sliding/tilting sunroof glass panel to tilted position.
- Carefully unclip bellows -1- from lower part of guide plate -3- using a removal wedge -3409- .
- Pull bellows -1- off securing pins -4-.
- Detach bellows -1- at top rear -2-.
- Remove bellows -1-.



1.4.2 Installing

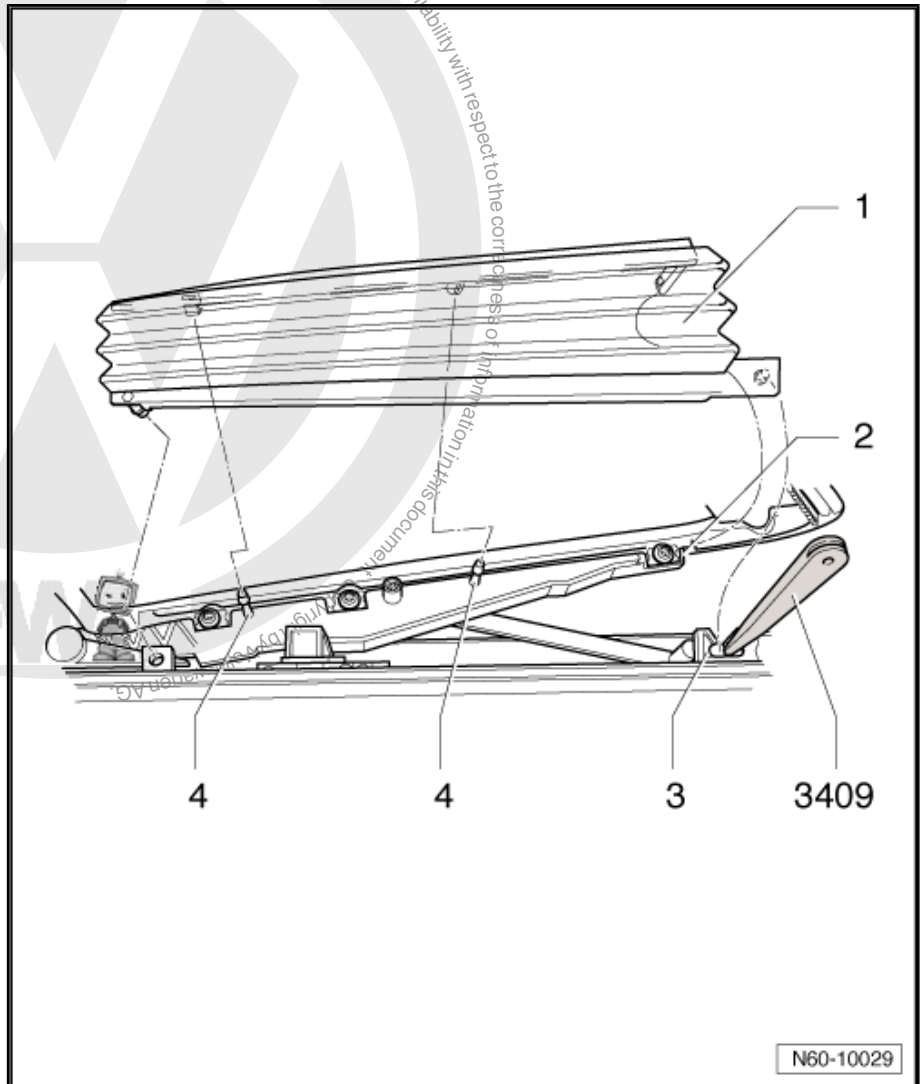

- Move sliding headliner to rear.
- Run sliding/tilting sunroof glass panel to tilted position.
- Fit bellows -1- first at top rear -2-.
- Clip bellows -1- with securing pins -4- in guide plate.
- Hook in bellows -1- at bottom rear -3- and clip in bellows, starting from front, in lower part of guide plate.

1.5 Removing glass panel of sliding/tilting sunroof

- Remove bellows ⇒ [page 122](#) .



- Remove bolts -1- on left and right.
- Remove sliding/tilting sunroof glass panel -2- out upwards.



WARNING

The guide plate must not be moved to "Open" position when removed, because the water channel will not be compressed by the glass panel and can become wedged together in the roof.

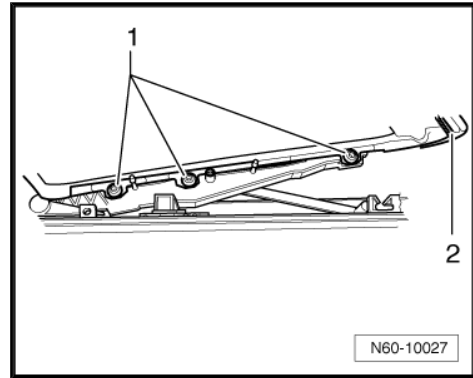

1.6 Installing glass panel of sliding/tilting sunroof

- Panel must be installed in 0 position (panel closed).

1.6.1 Zero position

The mark -arrow- on the rear of the guide upper section -1- must, on both sides, lie within the marks dimension -a- on the guide plate -2-.

The guide plate -2- must be located in the guide rails (cannot be moved by hand).

If this is not the case, adjust parallel running => [page 130](#).

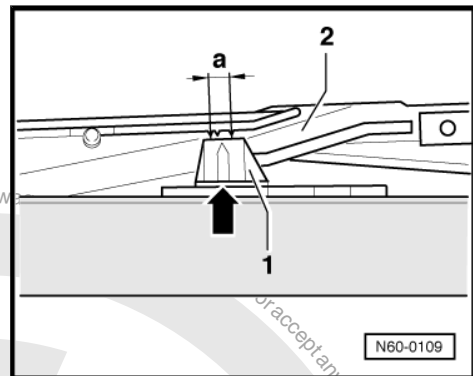

- Insert sliding/tilting sunroof glass panel -2- from above and fit bolts -1-.
- Lightly tighten bolts -1-.
- Adjusting height of glass panel of sliding/tilting sunroof: => [page 124](#)



Note

- ◆ After adjusting panel height, tighten securing screws (4.5 Nm).
- ◆ Install bellows after panel height adjustment.

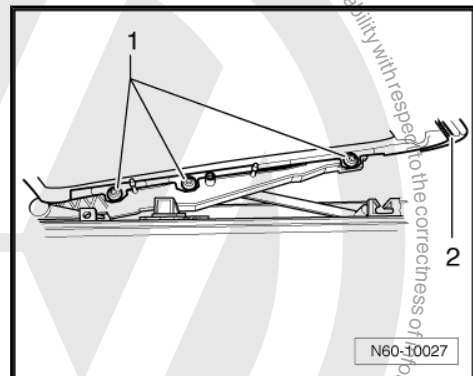

1.7 Adjusting height of glass panel of sliding/tilting sunroof



Note

The glass panel height adjustment is performed after the glass panel has been closed from slide open position.

Sliding/tilting sunroof glass panel 0 position OK.



- Remove bellows: ⇒ [page 122](#)
- Remove sliding/tilting sunroof glass panel -2- securing bolts -1-.
- Run sliding/tilting sunroof glass panel to “open” position.
- Run sliding/tilting sunroof glass panel to “closed” position.
- Carry out height adjustment of sliding/tilting sunroof glass panel at front and rear on both sides as follows:

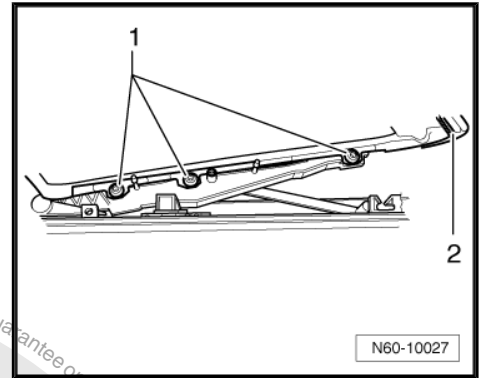

Panel adjustment front:

- a- = 0...1 mm lower than roof
- Arrow- = Forwards
- Tighten front screws (5 Nm).

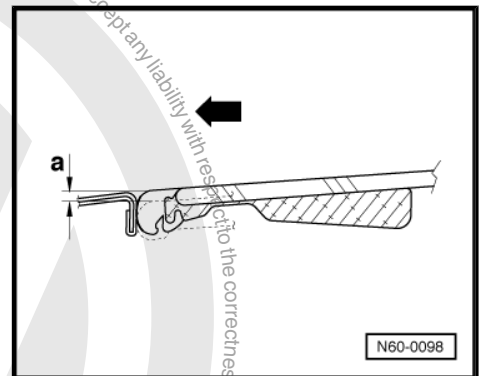

Panel adjustment rear:

- b- = 0...1 mm higher than roof
- Arrow- = Forwards
- First tighten middle and then rear screws (5 Nm).

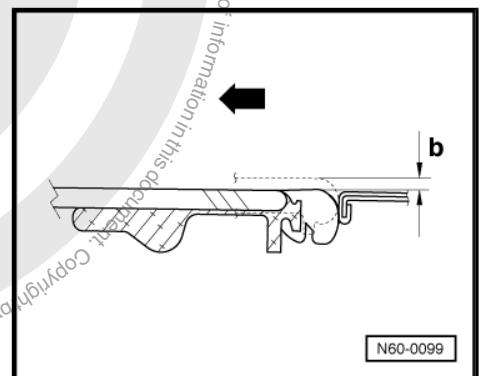

Note

- ◆ *To achieve the best possible optical appearance, ensure that the adjustment on left and right are as far as is possible uniform (symmetric).*
- ◆ *The glass panel should not be higher than the roof at any point at the front or lower than the roof at any point at the rear.*

- Install bellows ⇒ [page 123](#) .

1.8 Adjusting panel seal

- Check that the pre-loading between panel seal -2- and body is uniform all-round using a 0.3 mm thick strip of paper (a visiting card for example). It must be possible to pull the paper strip through tightly between the panel seal and body.
- Remove glass panel of sliding/tilting sunroof ⇒ [page 123](#) .
- The panel seal -2- can be pressed apart with a removal wedge -3409- -1- if the preload is insufficient

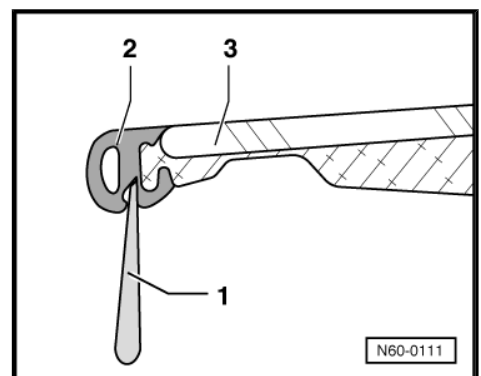



- If preload is too great press panel seal -1- together all-round with roller -3356- .

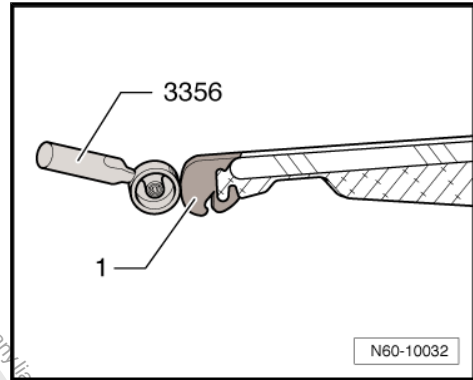

1.9 Renewing panel seal

- Remove glass panel of sliding/tilting sunroof ⇒ [page 123](#) .
- Pull seal -1- off sliding/tilting sunroof glass panel -2-.

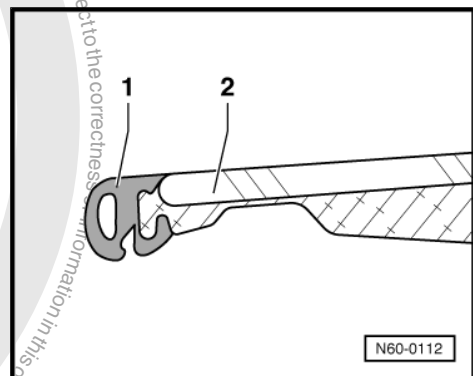

- Fit new seal -1- to rear edge of panel, start in middle and push onto sliding/tilting sunroof glass panel -2- from bottom to top.



Note

- ◆ To ease fitting of seal, coat panel edge with a soapy solution.
 - ◆ If the seal is not correctly installed, the surface will be wavy.
 - ◆ The panel seal must be shortened to suit the panel circumference.
- Install glass panel of sliding/tilting sunroof ⇒ [page 124](#) .
 - Adjusting panel seal ⇒ [page 125](#)

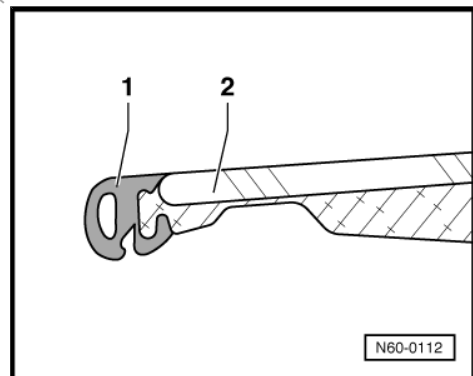

1.10 Removing and installing wind deflector

1.10.1 Removing

- Fully open sliding/tilting sunroof glass panel.



- Push wind deflector and height limit stop out at front of roof aperture and set wind deflector to vertical position.
- Place special tool front-end hook -3370- between edge of roof and wind deflector bearing -arrow-.
- Pull wind deflector bearings out of detent both sides in -direction of arrow- using special tool front-end hook -3370- .
- Remove wind deflector upwards out of guide rails.

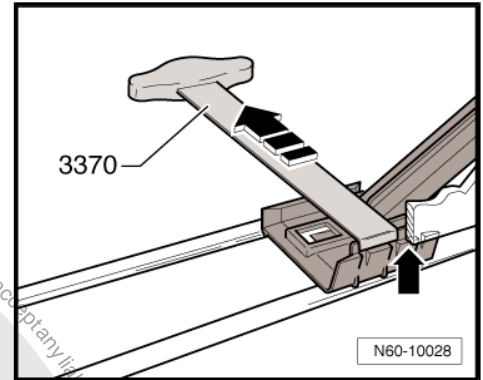

1.10.2 Installing

- Place wind deflector in guide rail and slide wind deflector with height limit stop under front of roof aperture on both sides.
- Using light pressure, press wind deflector bearings into guide rails.



Note

Wind deflector bearings must audibly engage in the guide rails.

1.10.3 Adjusting wind deflector on vehicles as of 08.2005

The wind deflector can be adjusted on vehicles as of 08. 2005.

- Place special tool front-end hook -3370- between edge of roof and wind deflector mounting -2-.
- Pull wind deflector mountings -2- out of locking devices of left and right guide rails in -direction of arrow- using special tool front-end hook -3370- .
- Slide wind deflector -1- parallel in guide rails -arrow b- until measurement -c- of between 0.3 mm and 1.3 mm is set.
- Press wind deflector -2- into guide rails.



Note

Wind deflector bearings must audibly engage in the guide rails.

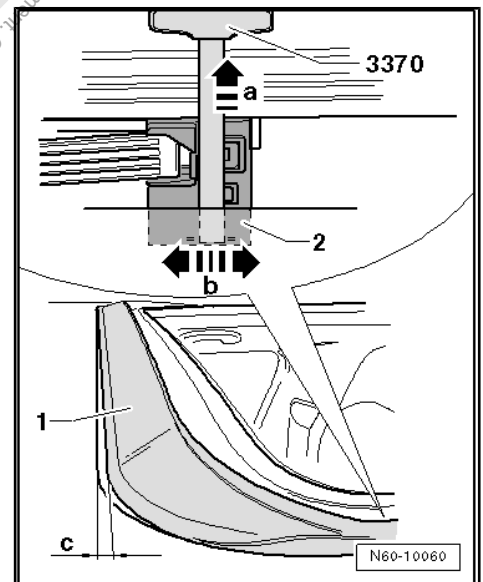

1.11 Removing and installing sliding headliner

1.11.1 Removing

- Remove glass panel for sliding/tilting sunroof: => [page 123](#) .



- Slide sliding headlining a little to rear.
- Remove front bolts -arrow- on left and right. Push spring slide forwards past the stop -1-.

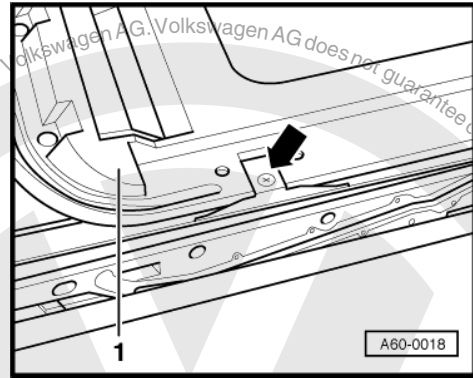

- Push sliding headlining forwards and lift it slightly past end of roof aperture.
- Remove rear bolts -arrow- both sides. Push spring slide to rear and remove sliding headlining -1- out upwards.

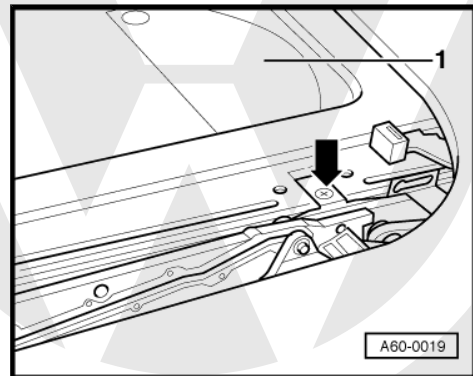

1.11.2 Installing

Installation is carried out in reverse order of removal.

- Finally carry out a functional check.

1.12 Removing and installing sliding/tilting sunroof glass panel drive

1.12.1 Removing

- Remove lights and operating unit ⇒ Electrical system; Rep. Gr. 96 ; Lights, bulbs, switches - interior; Lights and switches in roof trim; Removing and installing front interior light W1, vehicles with sunroof

Changing motor - preselection switch recognition:



Note

- ◆ *To interrupt the authorization signal and therefore to activate the switch recognition, the requirements described below must be fulfilled.*
- ◆ *If this is not the case, it can lead to, that the drive does not correctly recognise the preselection switch and does not run to the selected positions. This can be seen if the sunroof stops approx. 10 cm before the fully closed position when the switch is in the closed position.*



WARNING

Remove or install drive for tilting/sliding sunroof glass panel only when sunroof is closed (0 position).

The requirements for removing and installing drive are: Engine not running and ignition off, key not in ignition and door open.

- Switch off engine and ignition, withdraw key and open door.
- This condition must remain until drive has been installed.
- Remove screws -arrows- and pull off sliding/tilting sunroof drive.
- Separate connector for sliding/tilting sunroof drive.

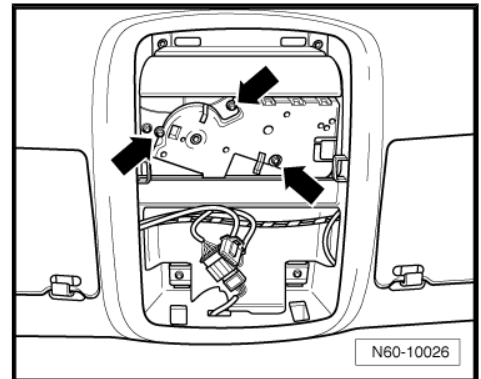

1.12.2 Installing

- The screws for the sliding/tilting sunroof drive are microencapsulated and must always be renewed (3.5 Nm).

Installation is carried out in reverse order of removal.

- After installation is complete the key can be placed in ignition and starter switch again.
- Finally carry out a functional check.

1.13 Adjusting drive for sliding/tilting sunroof glass panel (0 position)

There may be a requirement to adjust the 0 position if the drive was removed when not in 0 position or the sliding/tilting sunroof glass panel was opened or closed using the emergency key.

Drive removed but still connected electrically.

- Select "open sunroof" using preselection control rotary switch.
- Select "close sunroof" using preselection control rotary switch.
- Select "tilt sunroof" using preselection control rotary switch.
- Select "close sunroof" using preselection control rotary switch.
- Install drive in this position (0 position) with sliding/tilting sunroof glass panel closed.



- The sliding/tilting sunroof glass panel drive is in 0 position, if a white dot can be seen in the drive aperture -arrow-.

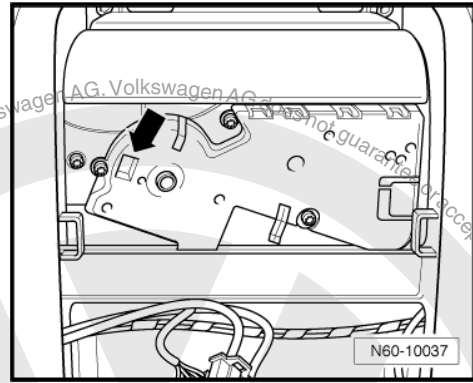

1.14 Removing and installing sliding/tilting sunroof glass panel automatic preselection switch

- Removing sliding/tilting sunroof glass panel automatic preselection switch ⇒ Electrical system; Rep. Gr. 96 ; Lights, bulbs, switches - interior; Removing and installing sliding sunroof switch

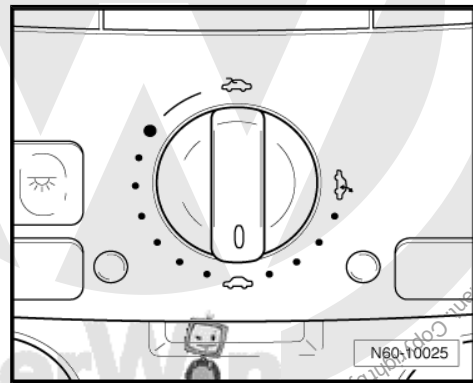

1.15 Checking parallel running

- Removing glass panel for sunroof ⇒ [page 123](#) .

The mark -arrow- on the rear of the guide upper section -1- must, on both sides, lie within the marks dimension -a- on the guide plate -2-.

The guide plate -2- must be located in the guide rails (cannot be moved by hand).

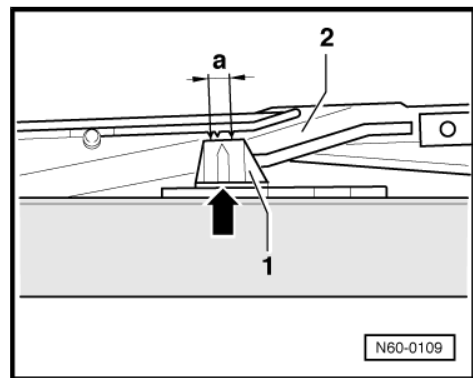

1.16 Adjusting parallel running



Note

The parallel running adjustment can only be made when the drive and glass panel are removed ("0" position).

- Remove sunroof glass panel drive ⇒ [page 128](#)



The mark -arrow- on the rear of the guide upper section -1- must, on both sides, lie within the marks dimension -a- on the guide plate -2-.

The guide plate -2- must be located in the guide rails (cannot be moved by hand).

- Push guide upper part -1- both sides centrally between the marks.
- Install drive (zero position) in this position.
- Then check zero position.

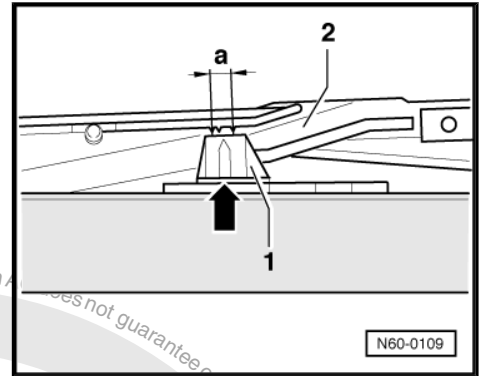

1.17 Assembly overview - carrier unit

1 - Carrier unit

- Removing and installing
 => [page 132](#)

2 - Bolt

- Qty. 12
- 8 Nm

3 - Connector

4 - Connections for water drainage hoses

5 - Sliding/tilting sunroof glass panel drive

- Removing and installing
 => [page 128](#)

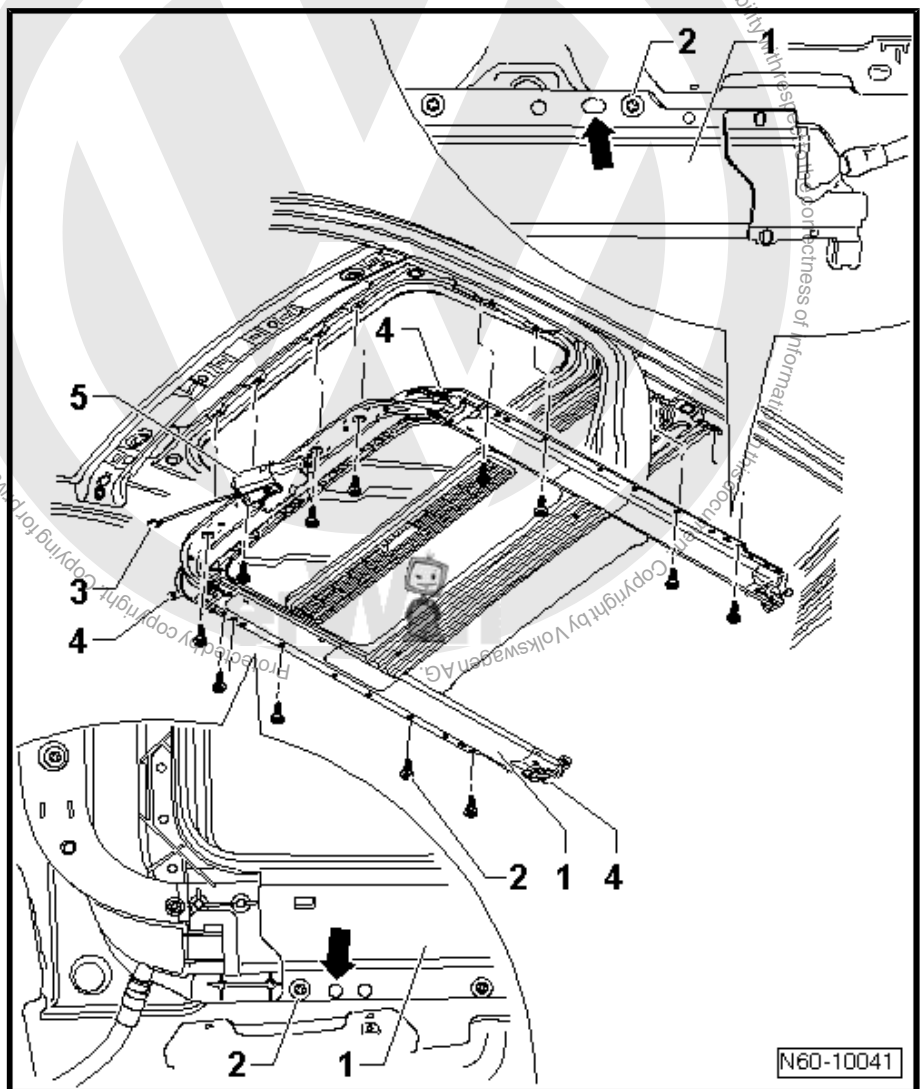



1.18 Removing and installing carrier unit



WARNING

Remove or install drive for tilting/sliding sunroof glass panel only when sunroof is closed (0 position).

The requirements for removing and installing drive are: Engine not running and ignition off, key not in ignition and door open.

1.18.1 Removing

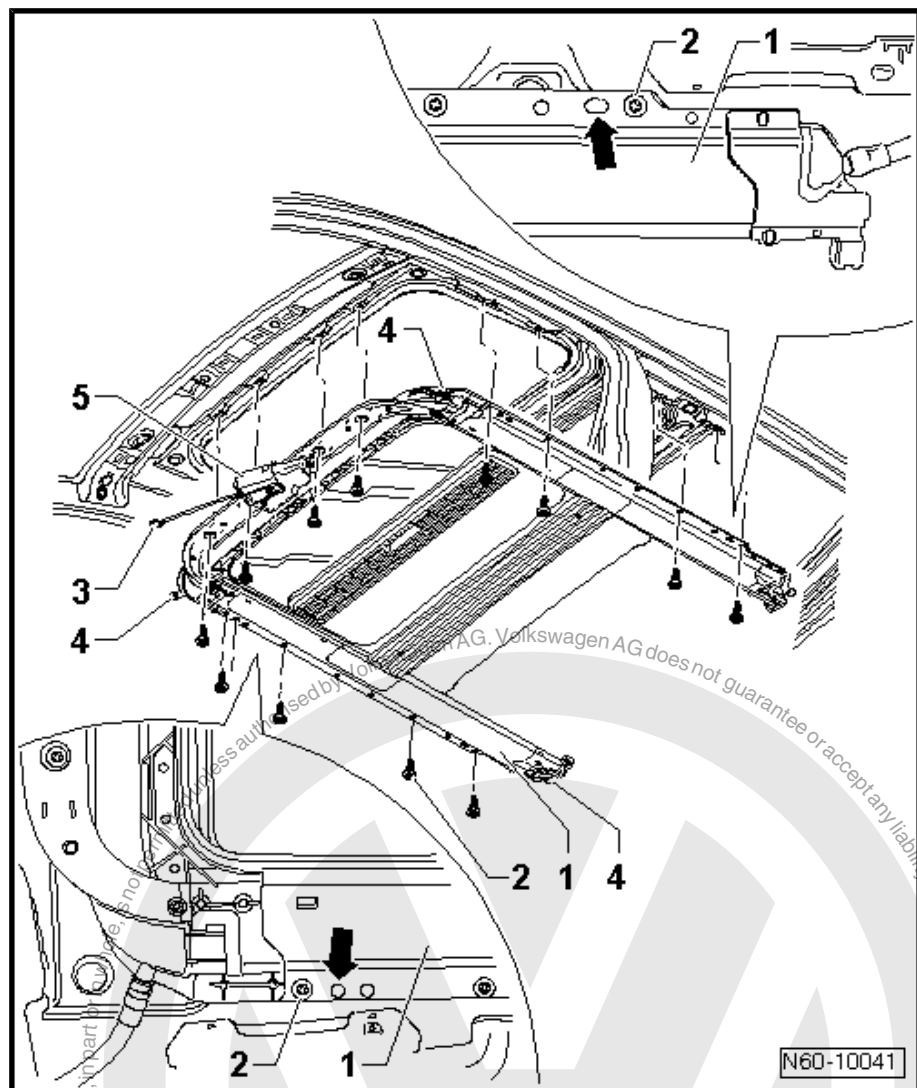

- Remove moulded headlining => General body repairs, interior; Rep. Gr. 70 ; Trims, insulation; Roof trims; Removing and installing moulded headlining .
- Pull off water drainage hoses -4- from carrier unit -1-.
- Separate connector -3- on sliding/tilting sunroof glass panel drive -5-.
- Remove screws -2- and remove carrier unit -1- from vehicle with the help of a second mechanic.



1.18.2 Installing

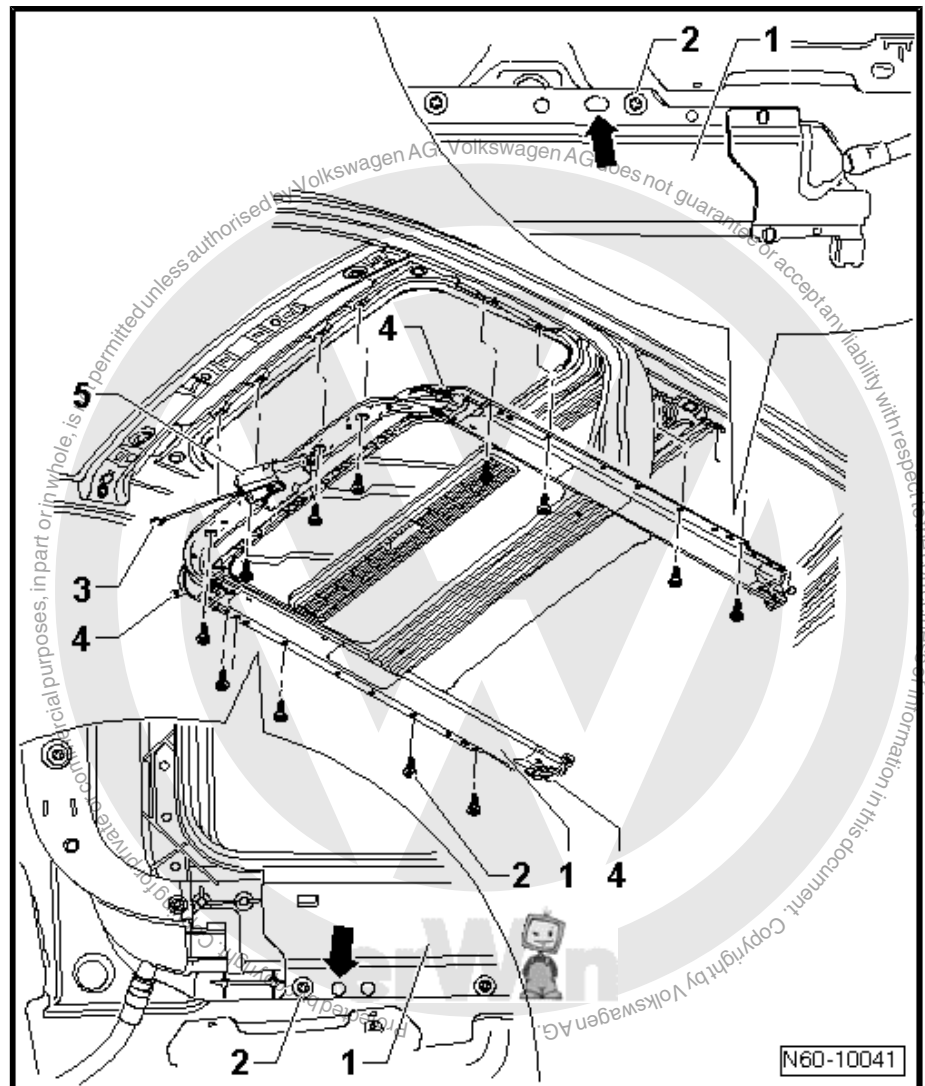

- Fit carrier unit -1- into roof aperture with the help of a second mechanic.
- During installation, align carrier unit -1- in roof via two cylindrical pins (shank end of drill) 12 mm front right -arrow- and 10 mm rear left -arrow-.

Carrier unit must not contact roof frame.

- Install bolts -2-.
- Check routing of wiring and connectors of electrical consumers in roof and restore if necessary.
- Tighten screws (8 Nm) for carrier unit -1-, starting at sunroof drive -5- and moving rearward, alternating between left and right sides.
- Install water drainage hoses -4-.
- Attach connector -3- on sliding/tilting sunroof glass panel drive -5-.
- Install moulded headlining ⇒ General body repairs, interior; Rep. Gr. 70 ; Trims, insulation; Roof trims; Removing and installing moulded headlining .



1.19 Operating without electrics



Note

In the event of power failure, the sliding/tilting sunroof with glass panel can be moved using a hexagon key directly on the drive. Hexagon key (crank) is housed in moulded headliner on right next to opening for rear interior light and reading lamp.

- Removing lights and operating unit ⇒ Electrical system; Rep. Gr. 96 ; Lights, bulbs, switches - interior; Lights and switches in moulded headlining .
- Guide hexagon key into bolt on drive.
- Press key upwards -arrow- to release the drive.

The bolt will be pressed a few millimetres inwards -a-. Sliding/tilting sunroof glass panel can only be moved in this position.

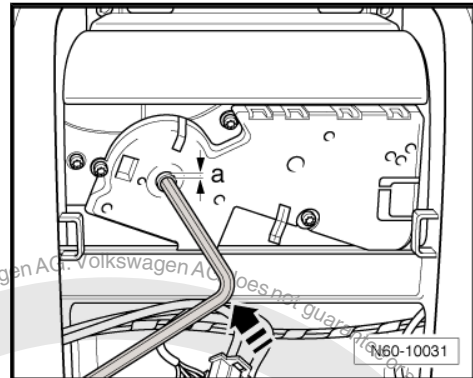

1.20 Removing and installing guide plate

1.20.1 Removing

- Remove glass panel of sliding/tilting sunroof ⇒ [page 123](#) .
- Unclip spacer -2- at front out of guide plate -1- and at rear out of locking hook guide -arrows- using a screwdriver.
- Pull spacer -2- in -direction of arrow- out of guide plate -1- and locking hook guide.

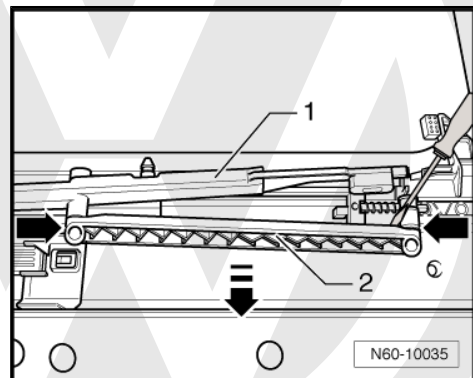

- Lift guide plate up -1- in -direction of arrow-.

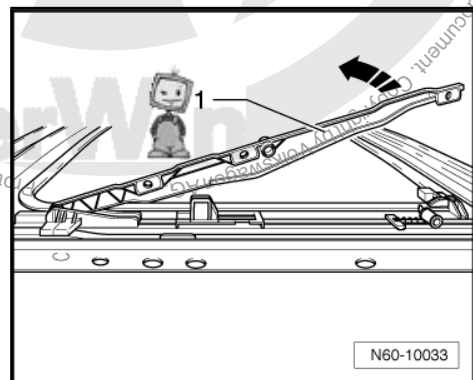



- Slide front guide -2- forwards and pull guide plate -1- in -direction of arrow- out of front guide -2-.

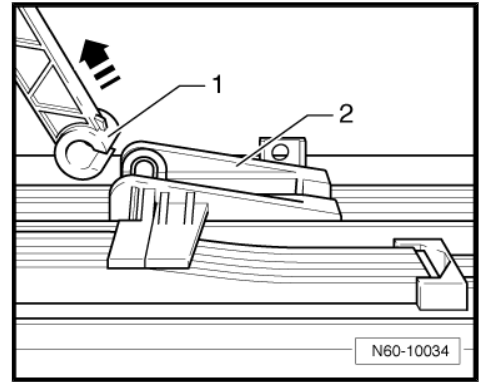

1.20.2 Installing

Installation is carried out in reverse order of removal.

1.21 Removing and installing sliding gate



Note

Always renew guide and cable as a pair.

1.21.1 Removing

- Remove glass panel of sliding/tilting sunroof => [page 123](#) .
- Remove carrier unit => [page 132](#) .
- Remove sunroof glass panel drive => [page 128](#)
- Remove guide plate => [page 134](#) .
- Detach water channels -1- carefully using a screwdriver at both sides on guide locating hook -2- in -direction of arrow- and remove water channels.

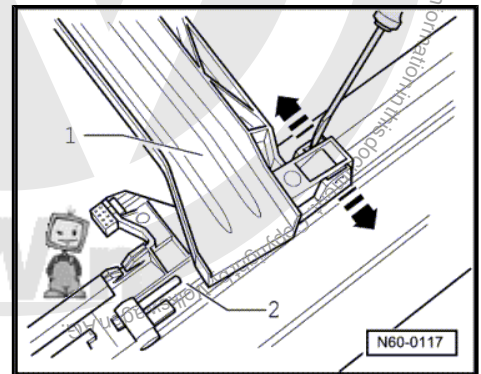

- Using a screwdriver, loosen clips -arrows- on end piece of upper part -1- from end piece lower part -2- and pull off end piece upper part.

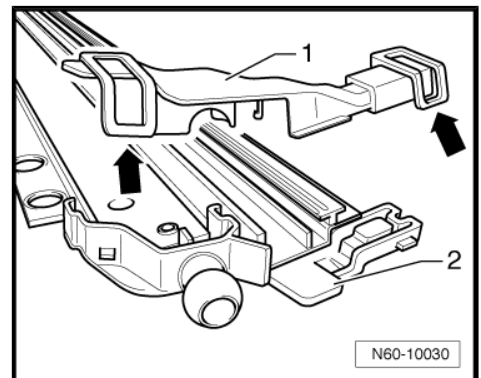



- Slide rear guide lower part -1- in -direction of arrow- in guide rail -3-, until the locating hook guide locking mechanism -2- is released.
- Pull out rear guide lower part -1- and locking hook guide -2- together in -direction of arrow- from guide rail -3- and remove.

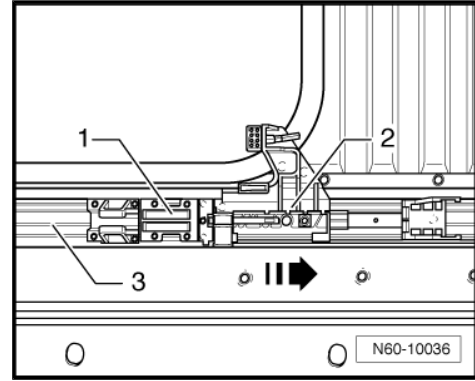

1.21.2 Installing

Installation is carried out in reverse order of removal.

1.22 Cleaning water drain hoses



Note

For cleaning, a locally manufactured tool made from a speedometer inner cable, approx. 2300 mm long is recommended.



1.22.1 Front water drain hoses

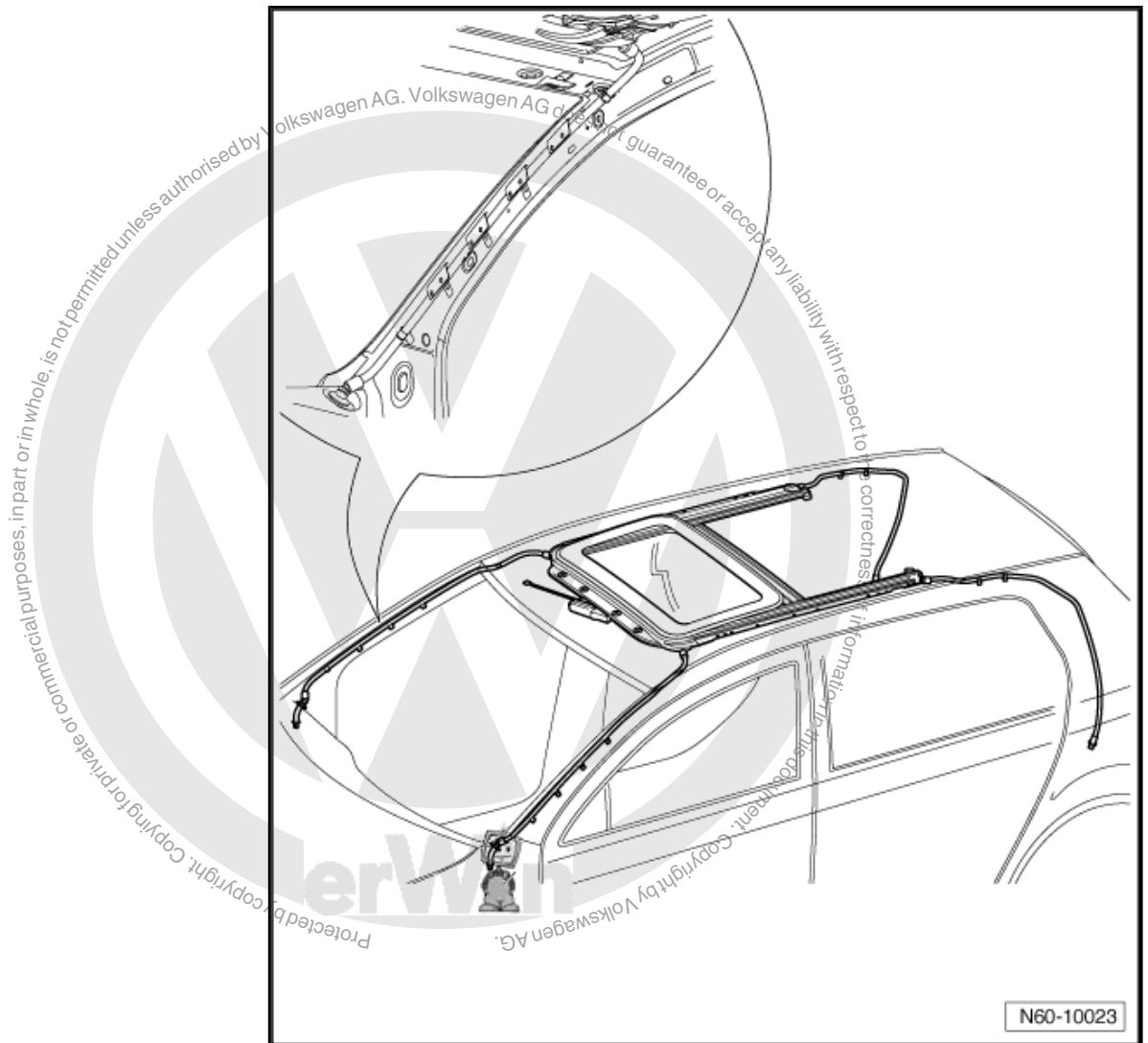

The front water drain hoses run through the A-pillars and end at the bulkhead cross member. Cleaning is done from the sunroof panel aperture.



1.22.2 Rear water drain hoses

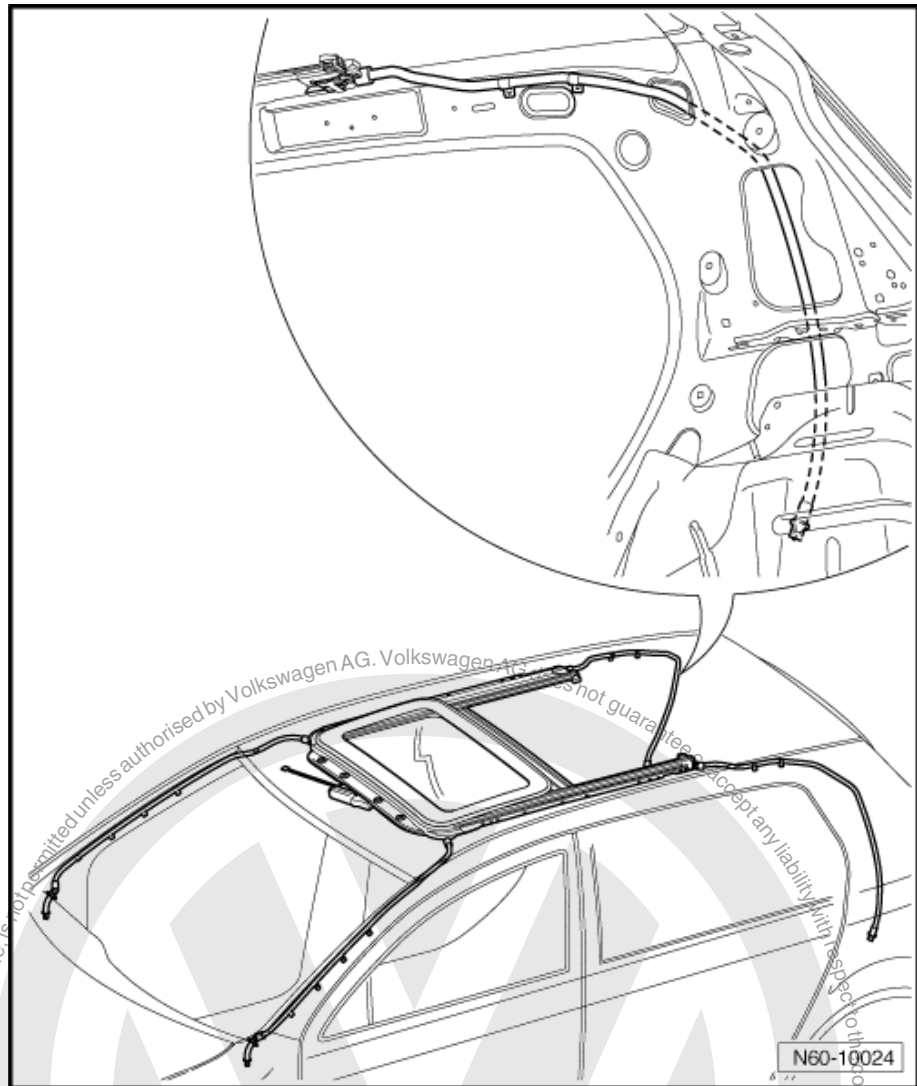

The rear water drain hoses run through the C-pillars and end in the rear wheel housings. Cleaning is done from the wheel housing. The wheel housing liner must be removed.



63 – Bumpers

1 Front bumper

1.1 Tools

Special tools and workshop equipment required

◆ Torque wrench -V.A.G 1783-

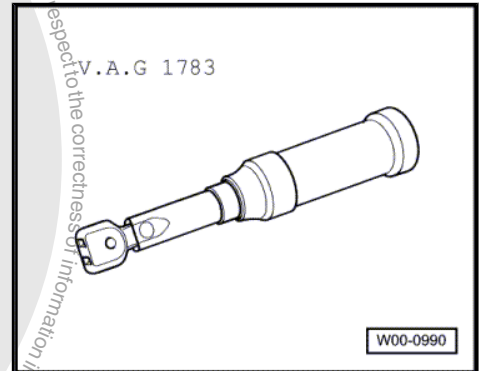

◆ Torque wrench -V.A.G 1332-

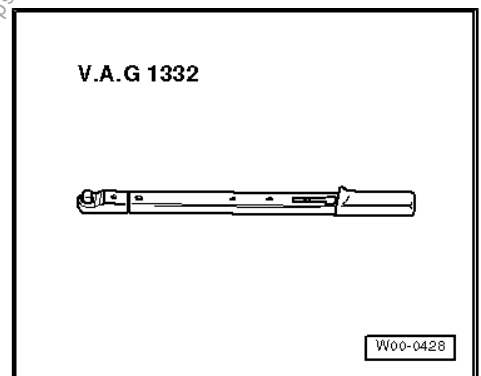

1.2 Repairing bumper cover



Note

If bumper cover is damaged, determine whether plastic can be repaired before renewing bumper

Details can be found under: ⇒ General Information; Body Repairs, General Body Repairs ; Work procedures; Plastic repair procedures .



1.3 Assembly overview - bumper cover

1 - Cover

- Material PP/EPDM
- Removing and installing
⇒ [page 140](#)

2 - Bolt

- 1.5 Nm

3 - Bolt

- Qty. 4 per side.
- 2 Nm

4 - Bolt

- Qty. 6
- 1.5 Nm

5 - Bolt

- Qty. 2
- 5 Nm

6 - Bolt

- Qty. 2
- 5 Nm

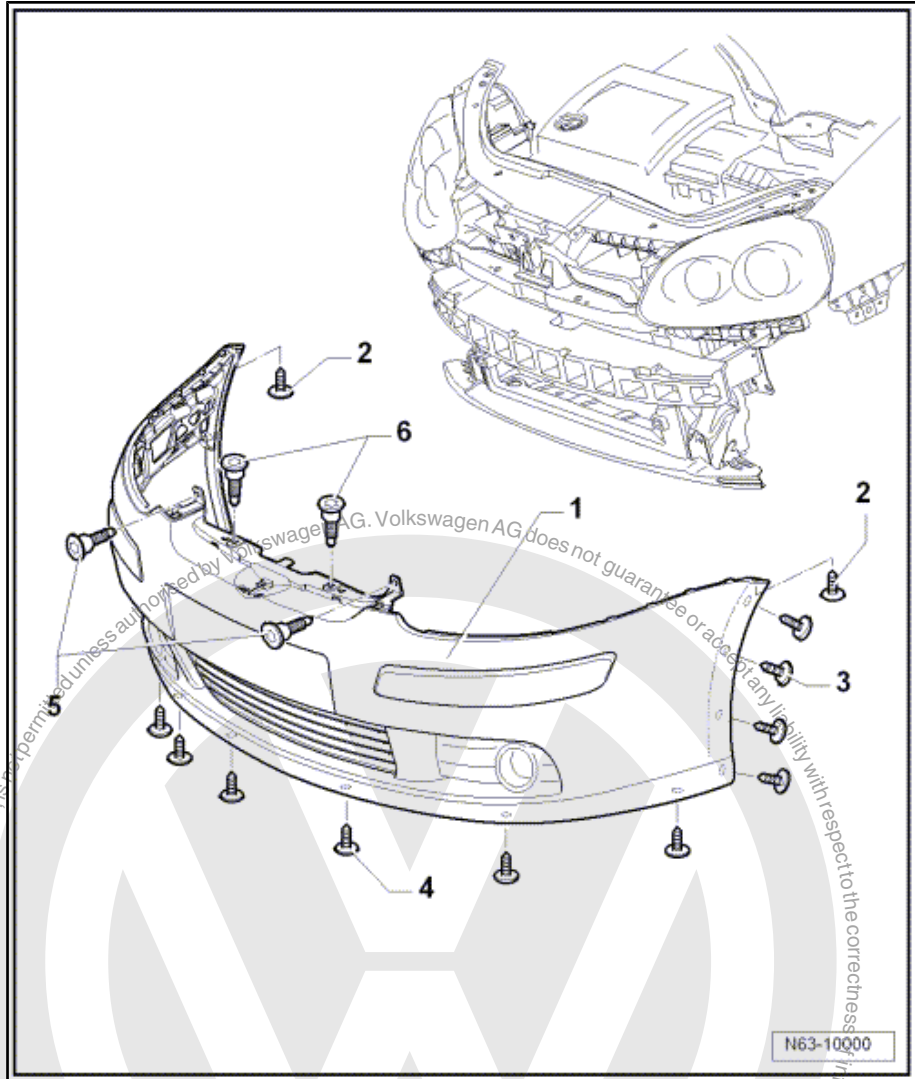

1.4 Removing and installing front bumper cover



Note

The removal and installation procedures may have to be modified slightly depending on version.



1.4.1 Removing

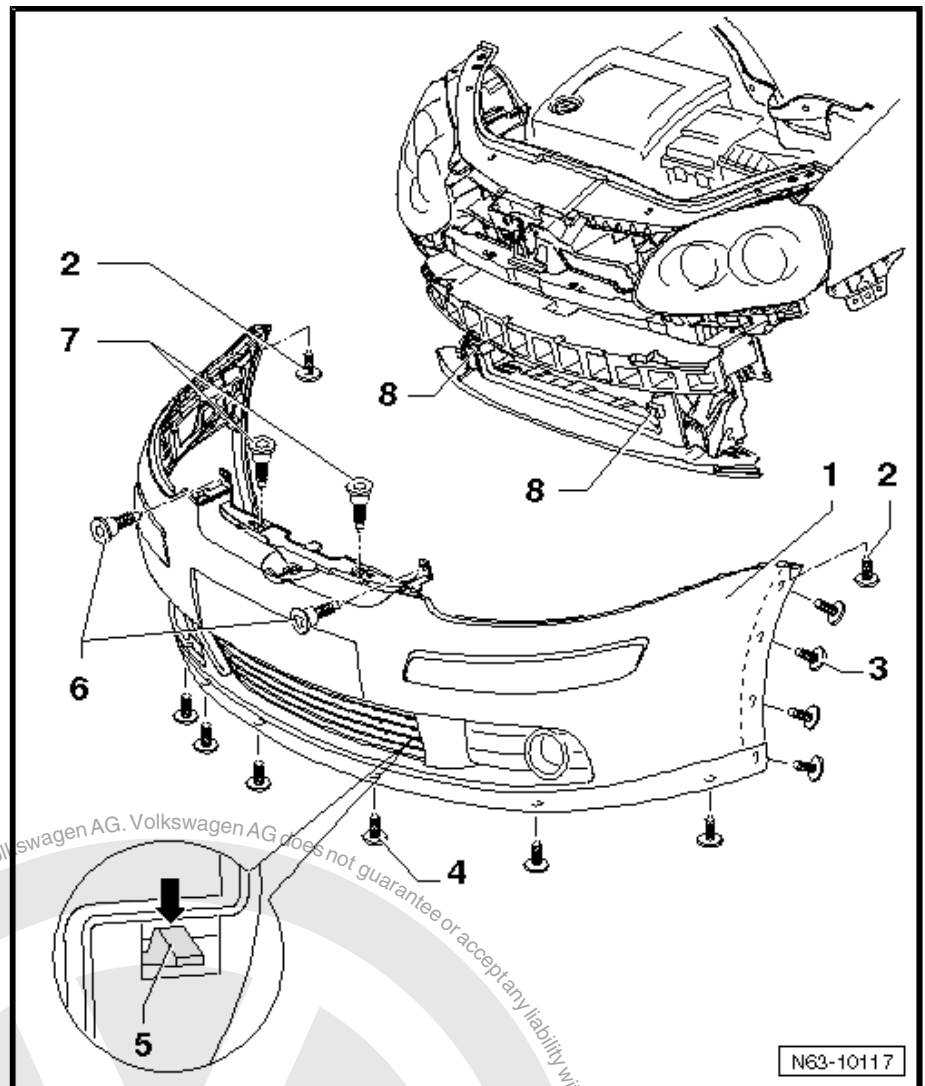

- Remove radiator grille ⇒ [page 230](#) .
- Remove bolts -5- and -6-.
- Remove bolts -4- from below.
- Remove bolts -3- and -2- (point upwards) on left and right in area of wheel housing liner.

Further dismantling is possible only with the help of a second mechanic.

- Press locking devices -5- downwards -arrow- on left and right sides and pull cover -1- parallel out of guide profiles with aid of a second mechanic.
- Disconnect all electrical connections from electrical components and separate hoses.

1.4.2 Installing

Installation is carried out in reverse order of removal.



- Ensure that gaps are parallel and specified dimensions are maintained => Body Repairs; Rep. Gr. 00 ; Technical data; Body gap dimensions .

1.5 Front bumper attachments



Note

Minor differences will be encountered on removal and installing, depending on version.

1 - Cover

- Material PP/EPDM
- Removing and installing
=> [page 140](#)

2 - Side marker light

- Left and right
- Not for all countries
- Removing => Electrical system; Rep. Gr. 94 ; Removing side marker lights .

3 - Left bumper moulded strip

- Material PP/EPDM
- Engaged in cover
- Bumper strip can be levered out of fastenings carefully from outside using a plastic wedge and removed

4 - Left air intake grille

- Pull forwards out of detents in -direction of arrow-

5 - Moulded part

- Not for all countries
- Engaged in cover
- Can be removed only when bumper has been removed

6 - Spoiler bracket

- Can be removed only when bumper has been removed

7 - Spoiler

- Material PC/ABS
- Engaged in cover
- Can be removed only when bumper has been removed

8 - Centre air intake grille

- Pull forwards out of detents in -direction of arrow-

9 - Bolt

- 1.5 Nm

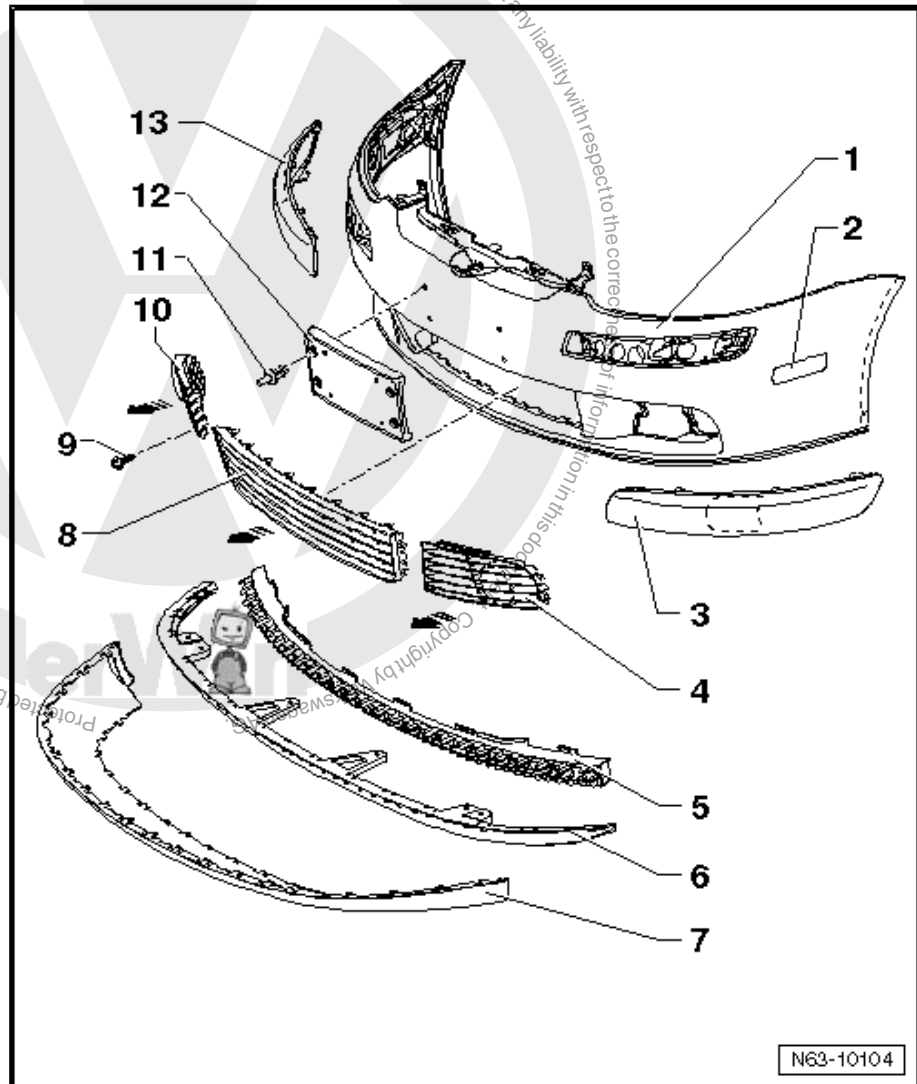



10 - Right air intake grille

- Remove bolt -8- and pull forwards out of fastening in -direction of arrow-

11 - Clip

- For separate number plate carrier
- Qty. 4

12 - Number plate carrier

- For various countries
- Installing => [Item 2 \(page 235\)](#)

13 - Right bumper strip

- Material PP/EPDM
- Engaged in cover.
- Bumper strip can be levered out of fastenings carefully from outside using a plastic wedge and removed

1.6 Front bumper substructure

1 - Left air duct

- Engages in lock carrier.

2- Left guide

- Bolted to lock carrier.

3 - Bolt

- Qty. 2 per retainer.
- 2-Nm

4 - Transverse member for pedestrian protection

- Not for all countries

5 - Bolt

- Qty. 6
- 8 Nm

6 - Right air duct

- Engages in lock carrier.

7 - Bolt

- Qty. 2 per retainer
- 2 Nm

8 - Right guide

- Bolted to bumper carrier

9 - Spreader nut

- Qty. 3

10 - Guide

- Left and right
- Removing:
 - On side of wing remove with bolts -11-

11 - Bolt

- Qty. 3
- 2 Nm

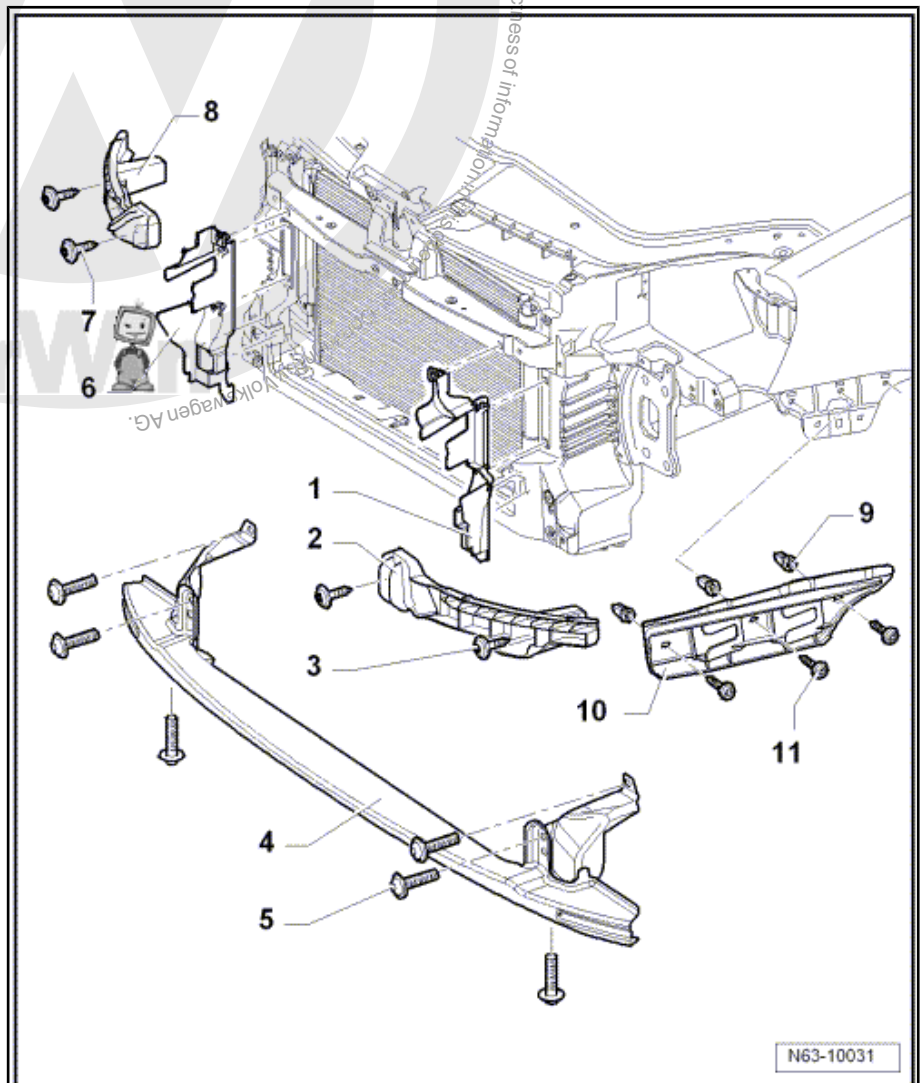



1.7 Assembly overview - bumper carrier

- 1 - Bumper carrier
- 2 - Bolt
 - Qty. 4 per side.
 - 60 Nm
- 3 - Bolt
 - Qty. 6
 - 8 Nm
- 4 - Foam piece
 - Self-adhesive
 - Available in various shapes

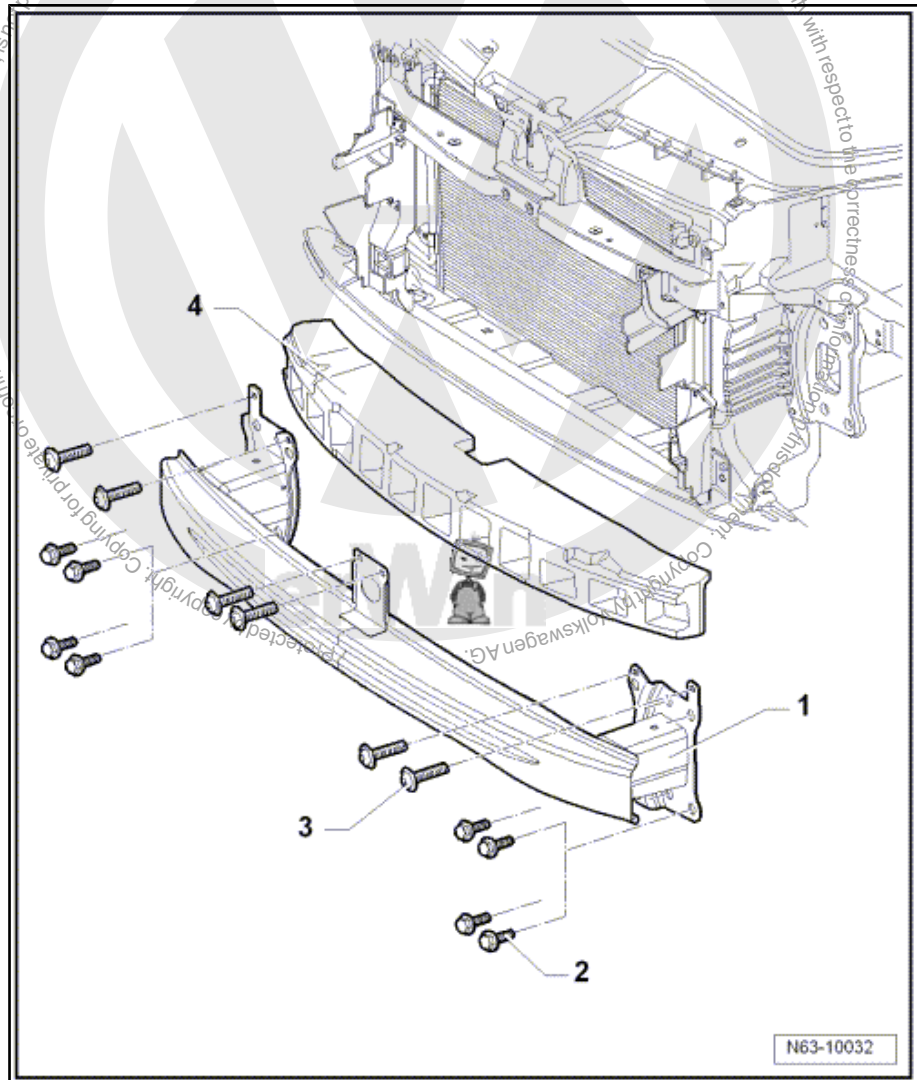



1.8 Assembly overview - number plate carrier

1 - Bumper cover

2 - Number plate carrier

- Not for all countries
- Installing
 - Align number plate carrier -3-, mark position of holes and drill-out
 - Insert clips

3 - Centre line

4 - Clip

- Qty. 4

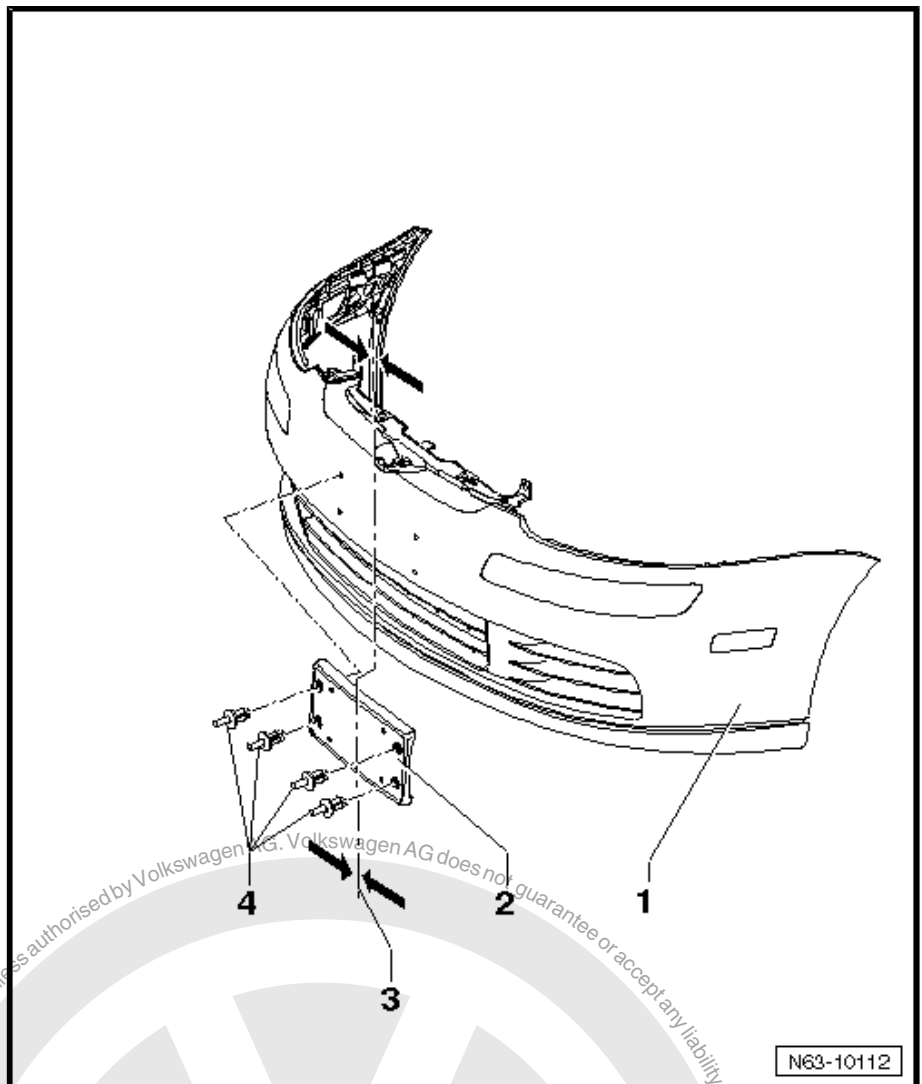

Protected by copyright. Copying for private or commercial purposes, in part or in whole, is not permitted unless authorised by Volkswagen AG. Volkswagen AG does not guarantee or accept any liability with respect to the correctness of information in this document. Copyright by Volkswagen AG.



2 Front bumper for GTI, GTI special models, GT, R32

2.1 Tools

Special tools and workshop equipment required

- ◆ Torque wrench -V.A.G 1783-

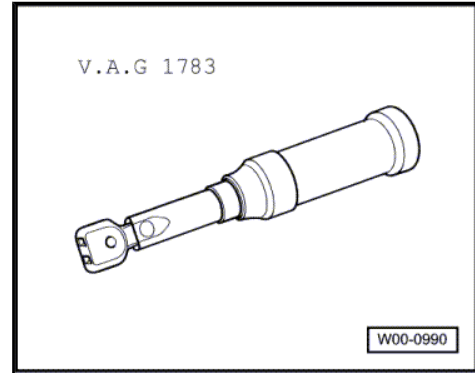

- ◆ Torque wrench -V.A.G 1332-

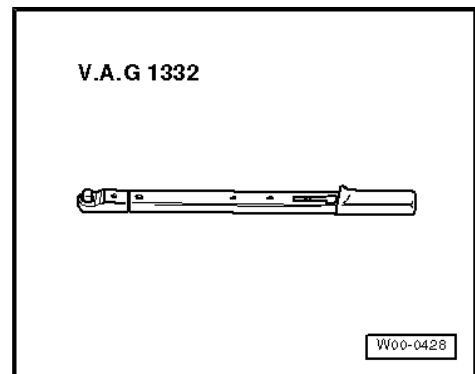

2.2 Repairing bumper cover



Note

If bumper cover is damaged, determine whether plastic can be repaired before renewing bumper

Details can be found under: ⇒ General Information; Body Repairs, General Body Repairs ; Work procedures; Plastic repair procedures .

2.3 Assembly overview - bumper cover for GTI, GT



Note

The bumper covers of the Golf GT and Golf GTI are identical. Only the air grilles are different.



1 - Cover

- Material PP/EPDM
- Removing and installing
⇒ [page 147](#)

2 - Bolt

- 1.5 Nm

3 - Bolt

- Qty. 4 per side.
- 2 Nm

4 - Bolt

- Qty. 8
- 1.5 Nm

5 - Bolt

- Qty. 2
- 5 Nm

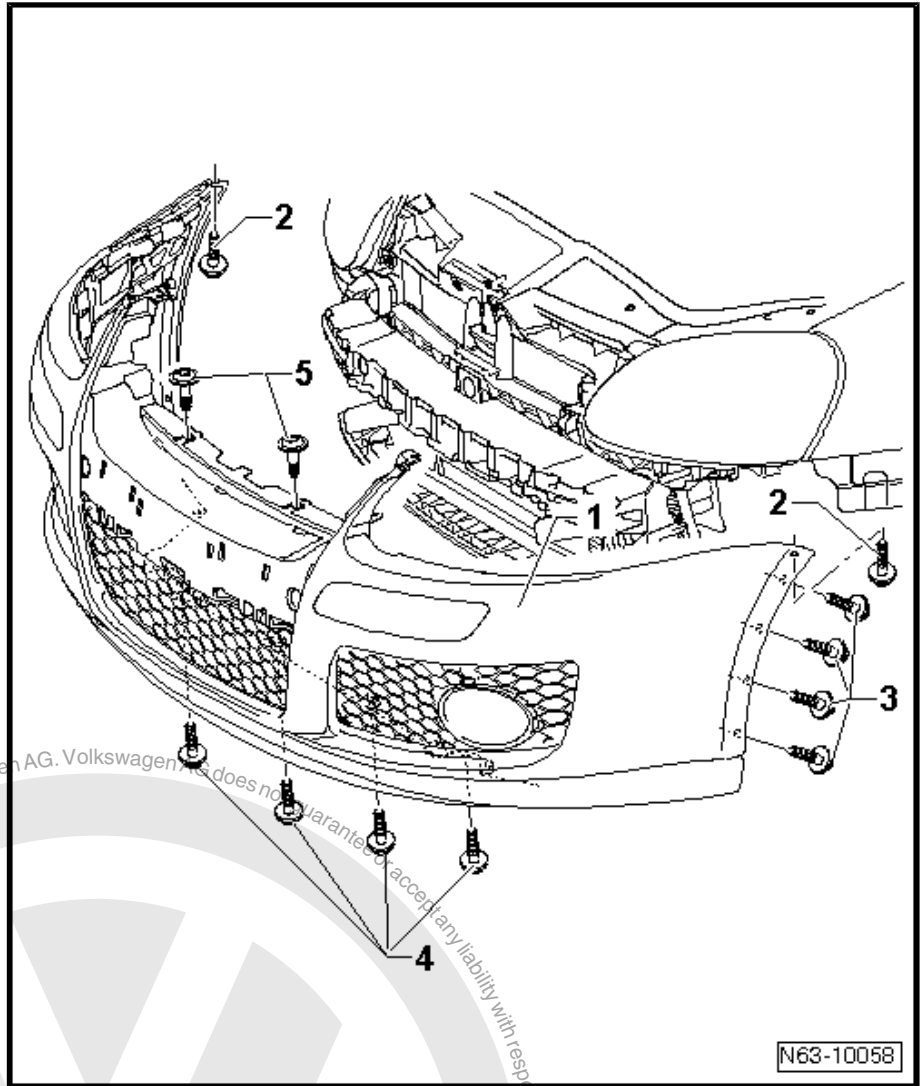

2.4 Removing and installing front bumper cover for GT, GTI



Note

The removal and installation procedures may have to be modified slightly depending on version.



2.4.1 Removing

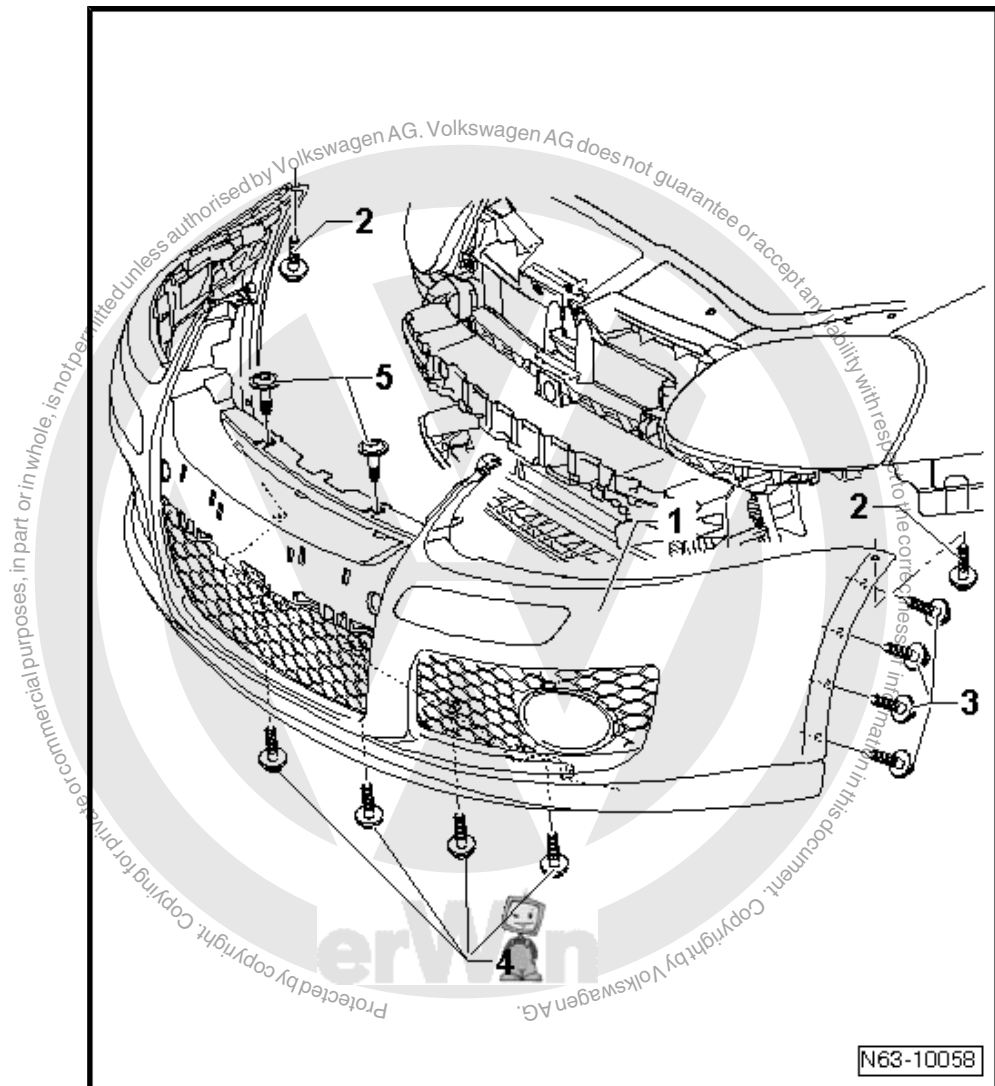

- Remove radiator grille ⇒ [page 233](#) .
- Remove bolts -5-.
- Remove bolts -4- from below.
- Remove bolts -3- and -2- (point upwards) on left and right in area of wheel housing liner.

Further dismantling is possible only with the help of a second mechanic.

- With help of a second mechanic pull cover -1- parallel out of guides.
- Disconnect all electrical connections from electrical components and separate hoses.

2.4.2 Installing

Installation is carried out in reverse order of removal.

- Ensure that gaps are parallel and specified dimensions are maintained ⇒ Body Repairs; Rep. Gr. 00 ; Technical data; Body gap dimensions .



2.5 Front bumper attachments for GT, GTI

Note

- ◆ *Minor differences will be encountered on removal and installing, depending on version.*
- ◆ *The bumper covers of the Golf GT and Golf GTI are identical. Only the air grilles are different.*
- ◆ *The air grille for the Golf GTI has a honeycomb pattern, the air grille for the Golf GT has transverse pieces.*

1 - Cover

- Material PP/EPDM
- Removing and installing
 ⇒ [page 147](#)

2 - Left bumper moulded strip

- Material PP/EPDM
- Engaged in cover
- Bumper strip can be levered out of fastenings carefully from outside using a plastic wedge and removed

3 - Side marker light

- Left and right
- Not for all countries
- Removing ⇒ Electrical system; Rep. Gr. 94 ; Removing side marker lights .

4 - Left air intake grille

- Different appearance for Golf GT and Golf GTI
- Removing:
 - Remove screw -4-
 - First remove forwards -arrow a- out of latches then pull out of cover towards centre of vehicle -arrow b-

5 - Bolt

- 1.5 Nm

6 - Spoiler upper part

- Material PC/ABS
- Engaged in cover
- Can be removed only when bumper has been removed and lower part of spoiler has been unbolted.

7 - Lower part of spoiler

- Only for Golf GTI
- Material PC/ABS
- Bolted to spoiler upper part and soundproofing

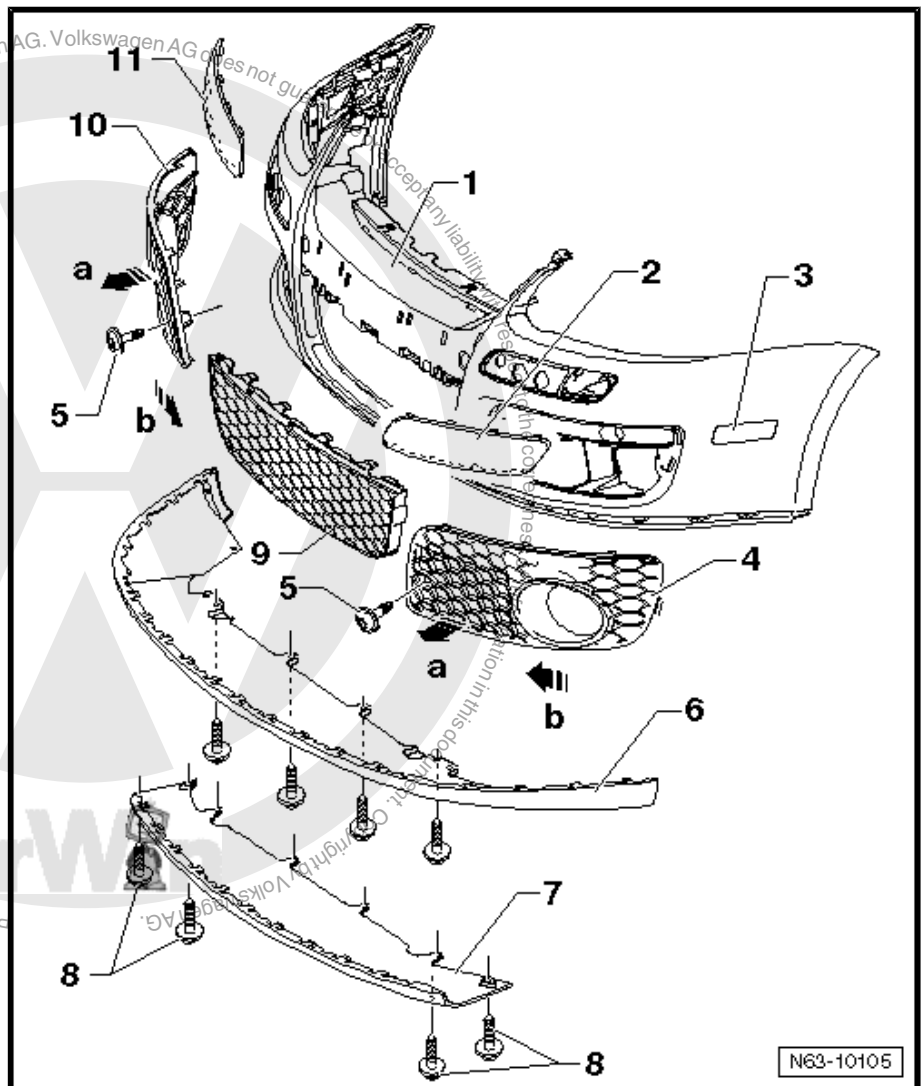



8 - Bolt

- Qty. 7
- 1.5 Nm

9 - Centre air intake grille

- Different appearance for Golf GT and Golf GTI
- Can only be removed when the radiator grille is removed
- Centre air intake grille can be levered out of latches carefully from outside using a plastic wedge and removed

10 - Right air intake grille

- Different appearance for Golf GT and Golf GTI
- Removing:
 - Remove screw -4-
 - First remove forwards -arrow a- out of latches, then pull out of cover towards centre of vehicle -arrow b-

11 - Right bumper moulded strip

- Material PP/EPDM
- Engaged in cover
- Bumper strip can be levered out of fastenings carefully from outside using a plastic wedge and removed





2.6 Assembly overview - bumper cover for R32



Note

Minor differences may be encountered in the assembly overview depending on version.

1 - Cover

- Material PP/EPDM
- Removing and installing
 ⇒ [page 151](#)

2 - Bolt

- Qty. 2
- 1 Nm

3 - Bolt

- Qty. 4 per side.
- 2 Nm

4 - Bolt

- Qty. 8
- 2 Nm

5 - Bolt

- Qty. 2
- 3.5 Nm

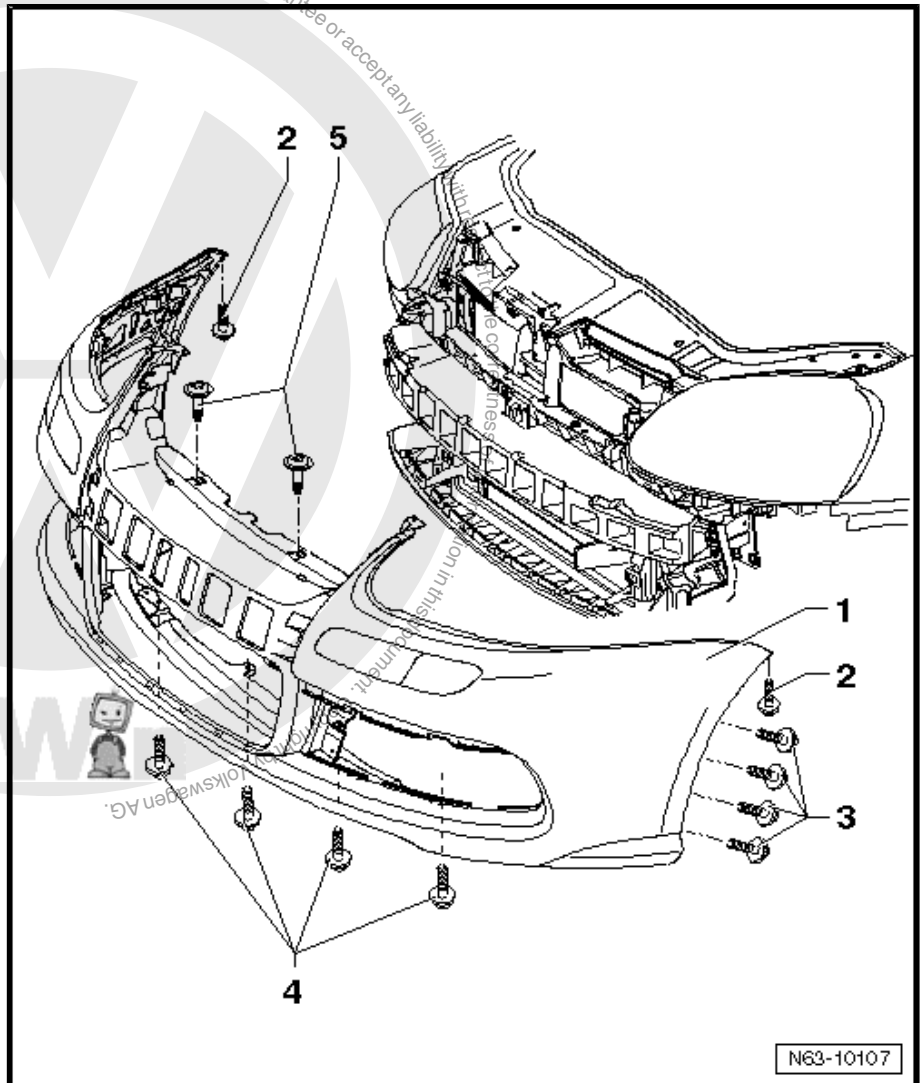

2.7 Removing and installing front bumper cover for R32



Note

The removal and installation procedures may have to be modified slightly depending on version.



2.7.1 Removing

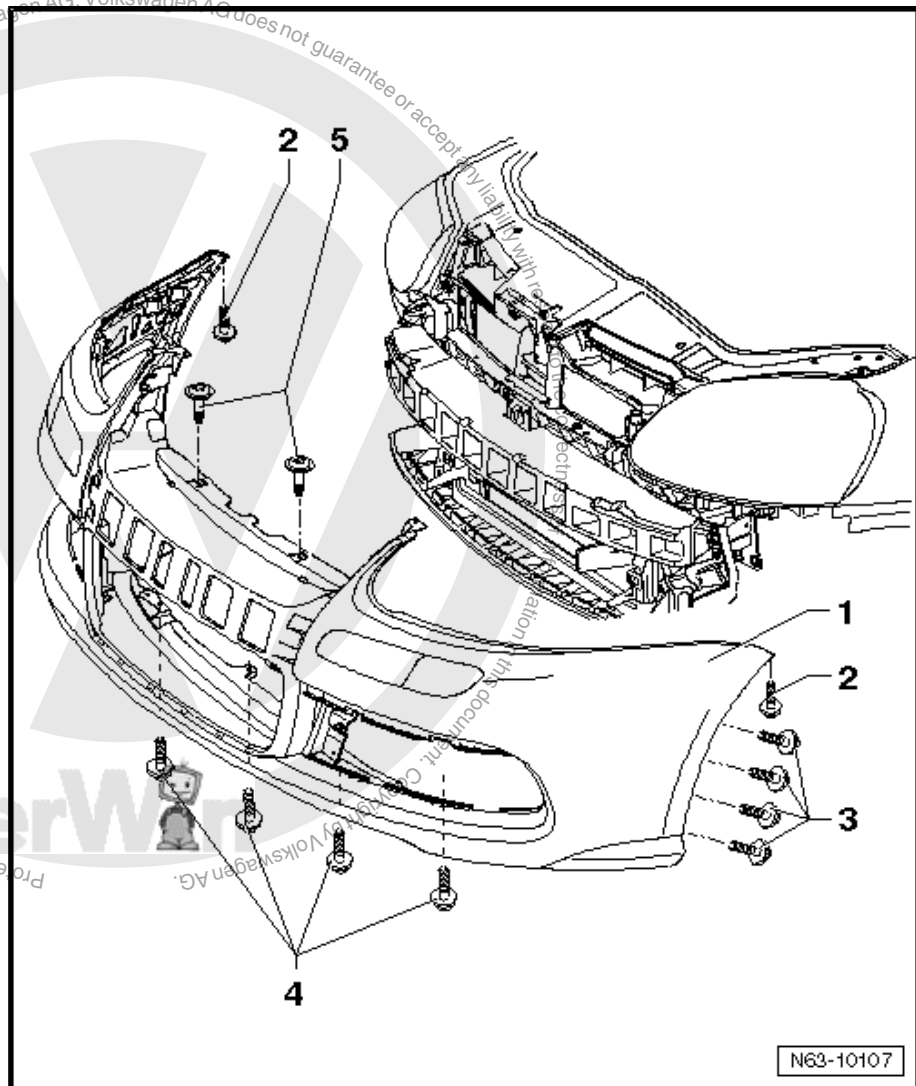

- Remove radiator grille ⇒ [page 237](#) .
- Remove bolts -5-.
- Remove bolts -4- from below.
- Remove bolts -3- and -2- (point upwards) on left and right in area of wheel housing liner.
- Remove side marker lights (if fitted) ⇒ Electrical system; Rep. Gr. 94 ; Side marker lights .

Further dismantling is possible only with the help of a second mechanic.

- With help of a second mechanic pull cover -1- parallel out of guides.
- Separate electrical connections of all electrical components.
- Disconnect hose of headlight washer system (if fitted) ⇒ Electrical system; Rep. Gr. 92 ; Headlight washer system .

2.7.2 Installing

Installation is carried out in reverse order of removal.



- Ensure that gaps are parallel and specified dimensions are maintained ⇒ Body Repairs; Rep. Gr. 00 ; Technical data; Body gap dimensions .

2.8 Front bumper attachments for R32



Note

Minor differences will be encountered on removal and installing, depending on version.

1 - Cover

- Material PP/EPDM
- Removing and installing ⇒ [page 151](#)

2 - Left side marker light

- For various countries
- Removing ⇒ Electrical system; Rep. Gr. 94 ; Removing side marker lights .

3 - Left air intake grille

- Removing ⇒ [page 237](#)

4 - Bolt

- Qty. 6 per side
- 1 Nm

5 - Cover for headlight washer system

6 - Left bumper strip

- Material PP/EPDM
- Engages in cover.
- Bumper strip can be levered out of fastenings carefully from outside using a plastic wedge and removed

7 - Right air intake grille

- Removing ⇒ [page 237](#)

8 - Right bumper moulded strip

- Material PP/EPDM
- Engages in cover.
- Bumper strip can be levered out of fastenings carefully from outside using a plastic wedge and removed

9 - Cover for headlight washer system

10 - Right side marker light

- For various countries
- Removing ⇒ Electrical system; Rep. Gr. 94 ; Removing side marker lights .

11 - Radiator grille

- Removing ⇒ [page 237](#)

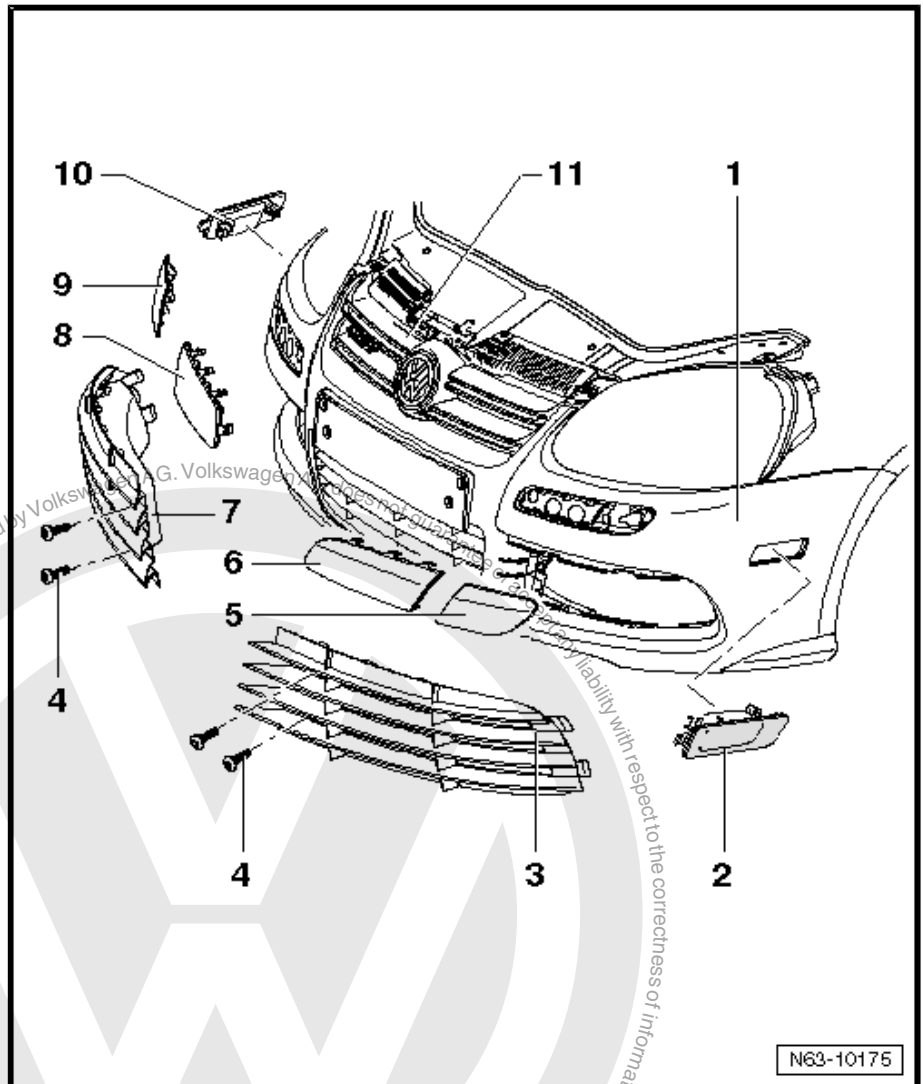



2.9 Assembly overview - front bumper cover for GTI special models



Note

Minor differences may be encountered in the assembly overview depending on version.

1 - Cover

- Material: PP/EPDM PU-RIM
- Removing and installing
⇒ [page 154](#)

2 - Bolt

- Points upwards
- 1.5 Nm

3 - Bolt

- Qty. 4 per side.
- 2 Nm

4 - Bolt

- Qty. 8
- 1.5 Nm

5 - Bolt

- Qty. 2
- 5 Nm

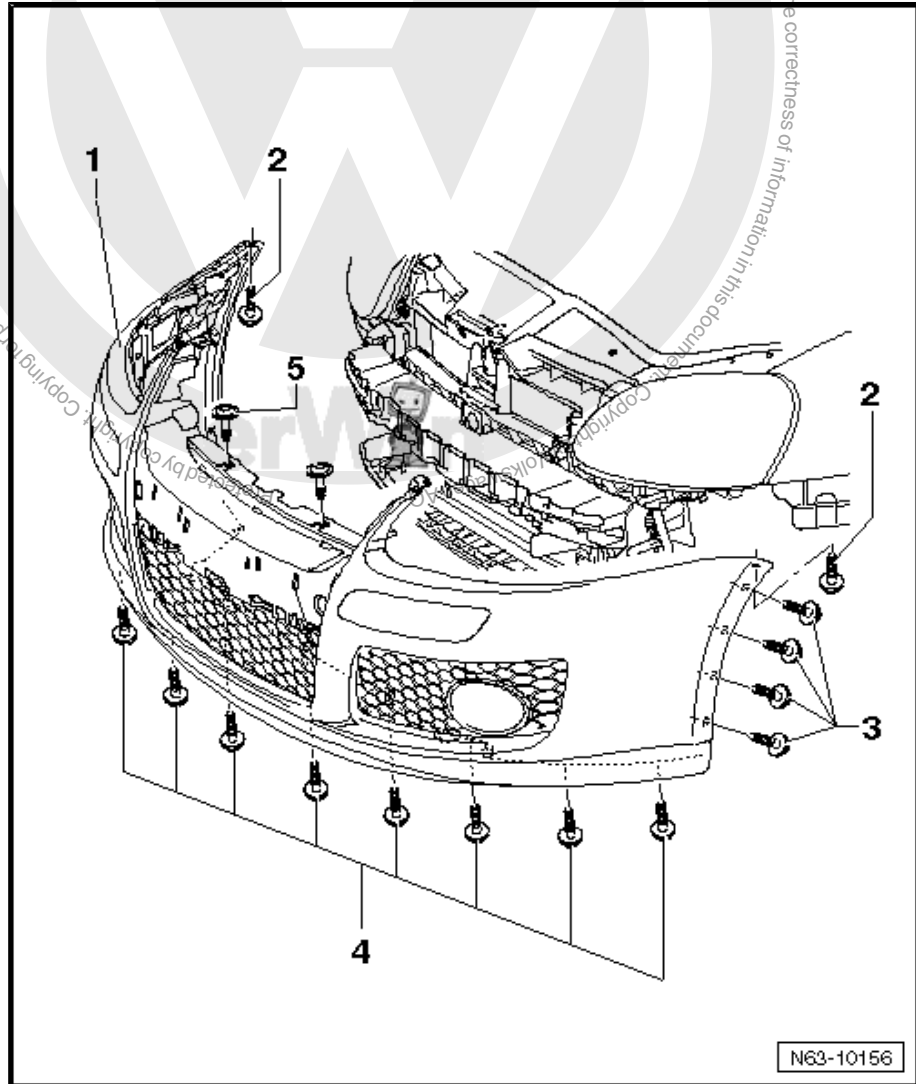

2.10 Removing and installing front bumper cover for GTI special models



Note

The removal and installation procedures may have to be modified slightly depending on version.



2.10.1 Removing

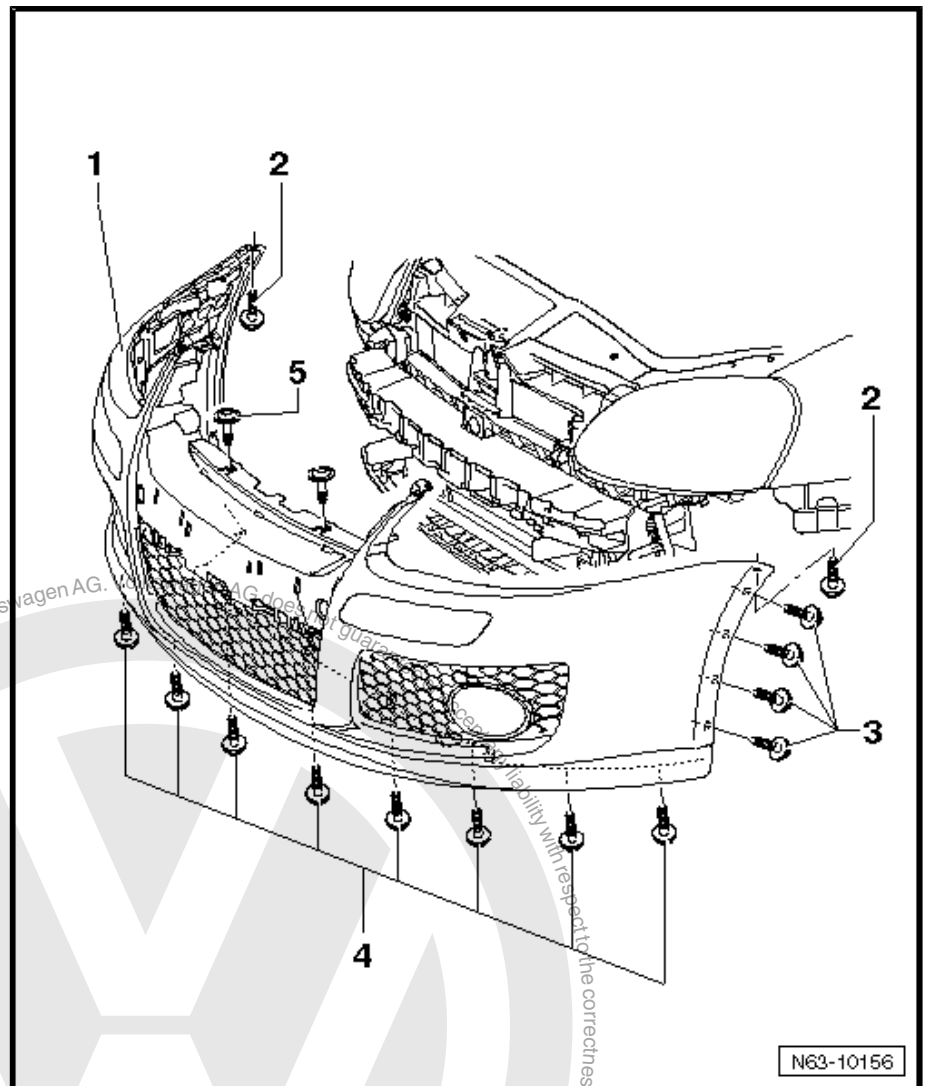

- Remove radiator grille ⇒ [page 233](#) .
- Remove bolts -5- from above.
- Remove bolts -4- from below.
- Remove bolts -3- and -2- (point upwards) on left and right in area of wheel housing liner.

Further dismantling requires the help of a second mechanic.

- With help of a second mechanic pull cover -1- parallel out of guides.
- Separate connectors of all installed electrical components and hoses ⇒ Electrical system; Rep. Gr. 92 ; Windscreen wash/wipe system; Headlight washer system .

2.10.2 Installing

Installation is carried out in reverse order of removal.

- Ensure that gaps are parallel and specified dimensions are maintained ⇒ Body Repairs; Rep. Gr. 00 ; Technical data; Body panel gaps/shut lines .



2.11 Front bumper attachments for GTI special models



Note

Minor differences will be encountered on removal and installing, depending on version.

1 - Cover

- Material: PP/EPDM PU-RIM
- Removing and installing
⇒ [page 154](#)

2 - Left bumper strip

- Material PP/EPDM
- Engaged in cover.
- Bumper strip can be levered out of fastenings carefully from outside using a plastic wedge and removed

3 - Left air intake grille

- Removing:
 - Unscrew bolt -4-.
 - First remove forwards -arrow a- out of catches, then pull out of cover towards centre of vehicle -arrow b-.

4 - Bolt

- 1.5 Nm

5 - Spoiler

- Material: PU-RIM
- Engaged in cover.
- Can be removed only when bumper has been removed and lower part of spoiler has been unbolted.

6 - Centre air intake grille

- Can only be removed when the radiator grille has been removed.
- Centre air intake grille can be levered out of catches carefully from outside with a plastic wedge and removed.

7 - Right air intake grille

- Removing:
 - Unscrew bolt -4-.
 - First remove forwards -arrow a- out of catches, then pull out of cover towards centre of vehicle -arrow b-.

8 - Right bumper strip

- Material PP/EPDM
- Engaged in cover.
- Bumper strip can be levered out of fastenings carefully from outside using a plastic wedge and removed

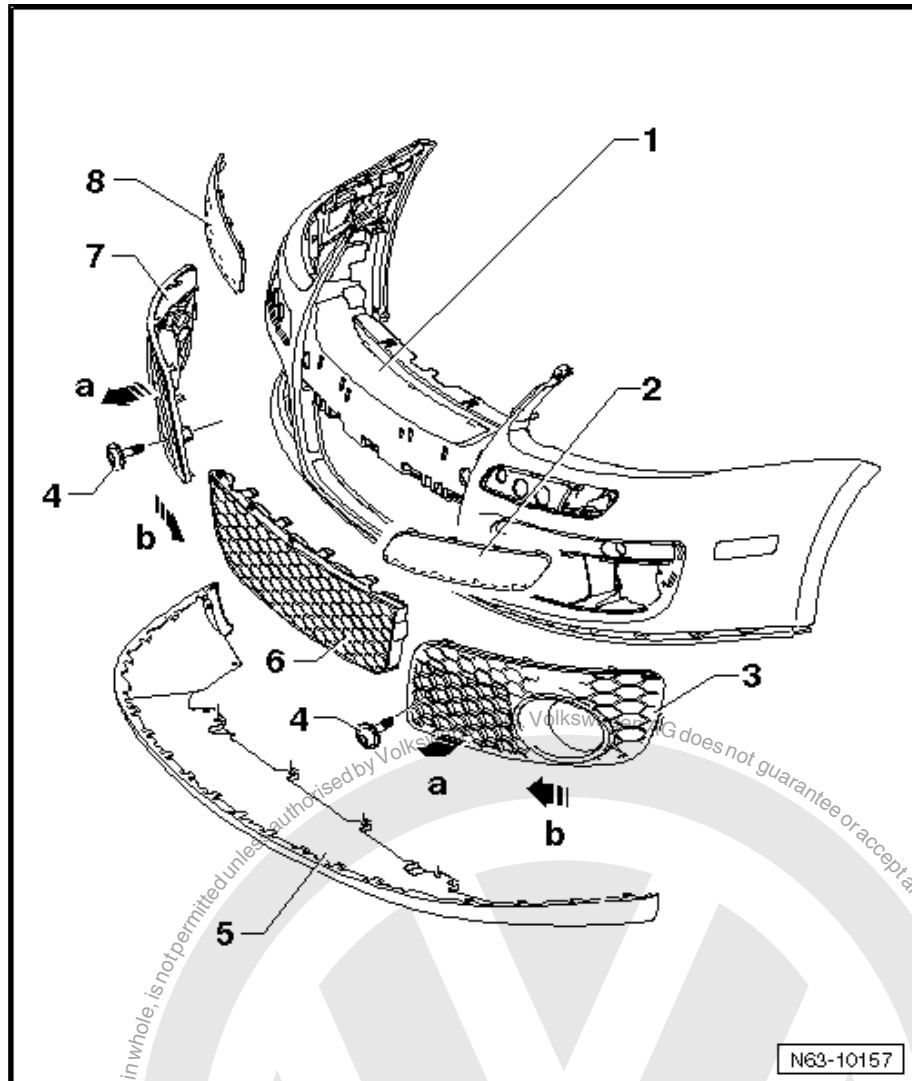



2.12 Front bumper substructure

1 - Left air duct

- Engages in lock carrier.

2 - Left guide

- Bolted to lock carrier.

3 - Bolt

- Qty. 2 per retainer.
- 2 Nm

4 - Transverse member for pedestrian protection

- Not for all countries

5 - Bolt

- Qty. 6
- 8 Nm

6 - Right air duct

- Engages in lock carrier.

7 - Bolt

- Qty. 2 per retainer
- 2 Nm

8 - Right guide

- Bolted to bumper carrier

9 - Spreader nut

- Qty. 3

10 - Guide

- Left and right
- Removing:
 - On side of wing, remove together with bolts -11-.

11 - Bolt

- Qty. 3
- 2 Nm

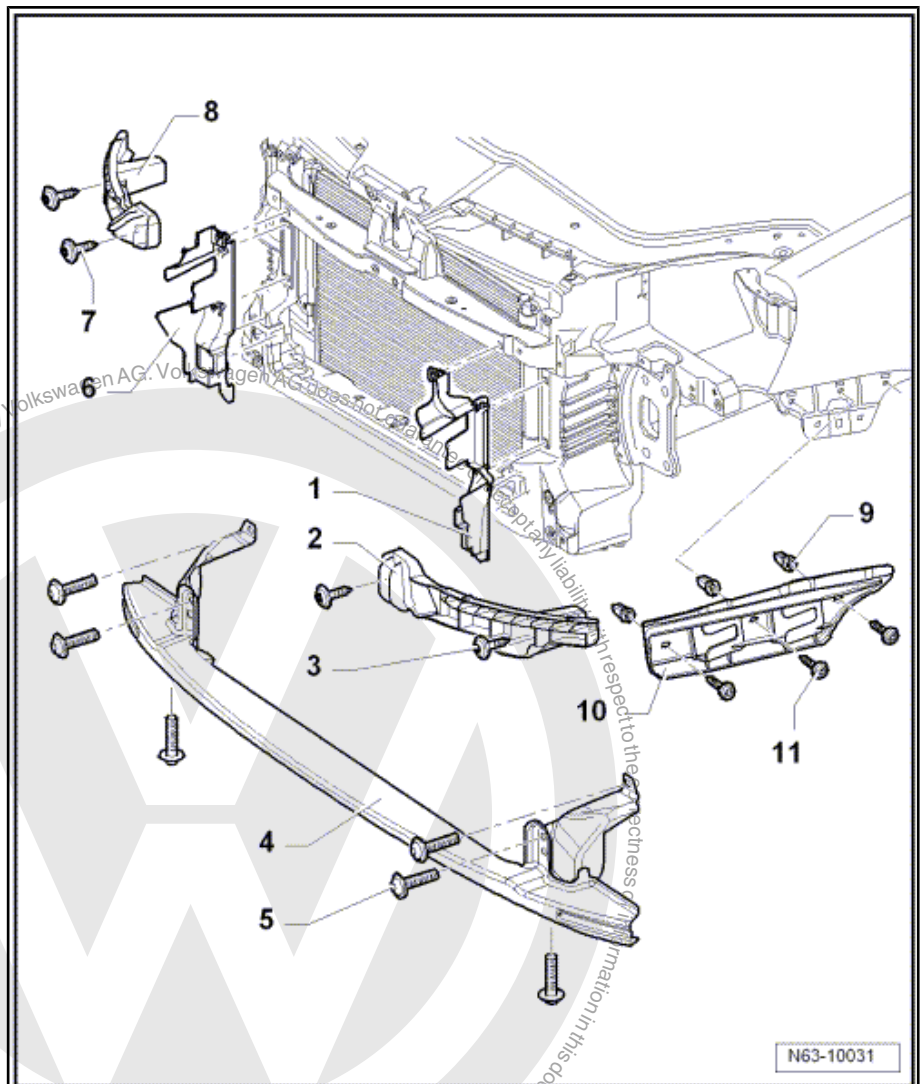



2.13 Assembly overview - bumper carrier

- 1 - Bumper carrier
- 2 - Bolt
 - Qty. 4 per side.
 - 60 Nm
- 3 - Bolt
 - Qty. 6
 - 8 Nm
- 4 - Foam piece
 - Self-adhesive
 - Available in various shapes

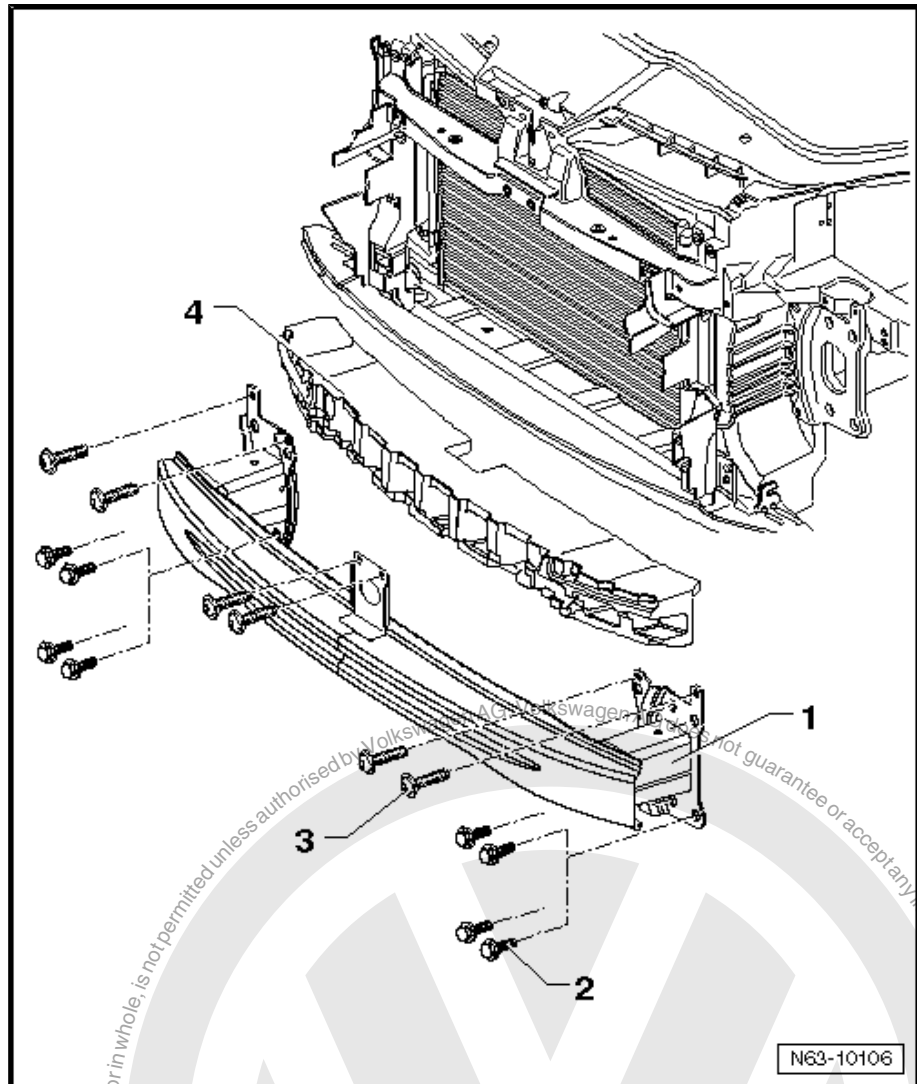



3 Rear bumper

3.1 Tools

Special tools and workshop equipment required

- ◆ Torque wrench -V.A.G 1783-

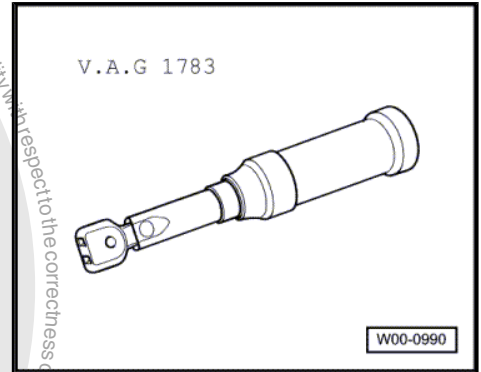

- ◆ Torque wrench -V.A.G 1331-

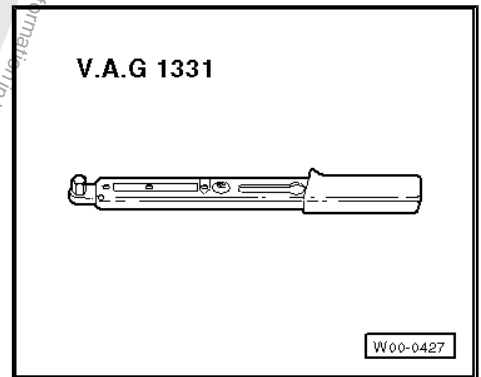

3.2 Repairing bumper cover



Note

If bumper cover is damaged, determine whether plastic can be repaired before renewing bumper

Details can be found under: ⇒ General Information; Body Repairs, General Body Repairs ; Work procedures; Plastic repair procedures .



3.3 Assembly overview - bumper cover

1 - Cover

- Material PP/EPDM
- Removing and installing
⇒ [page 160](#)

2 - Bolt

- Qty. 2
- 5 Nm

3 - Bolt

- Qty. 4
- 5 Nm

4 - Spreader rivet

- Qty. 2

5 - Bolt

- Qty. 3 per side
- 2 Nm

6 - Bolt

- Qty. 4
- 5 Nm

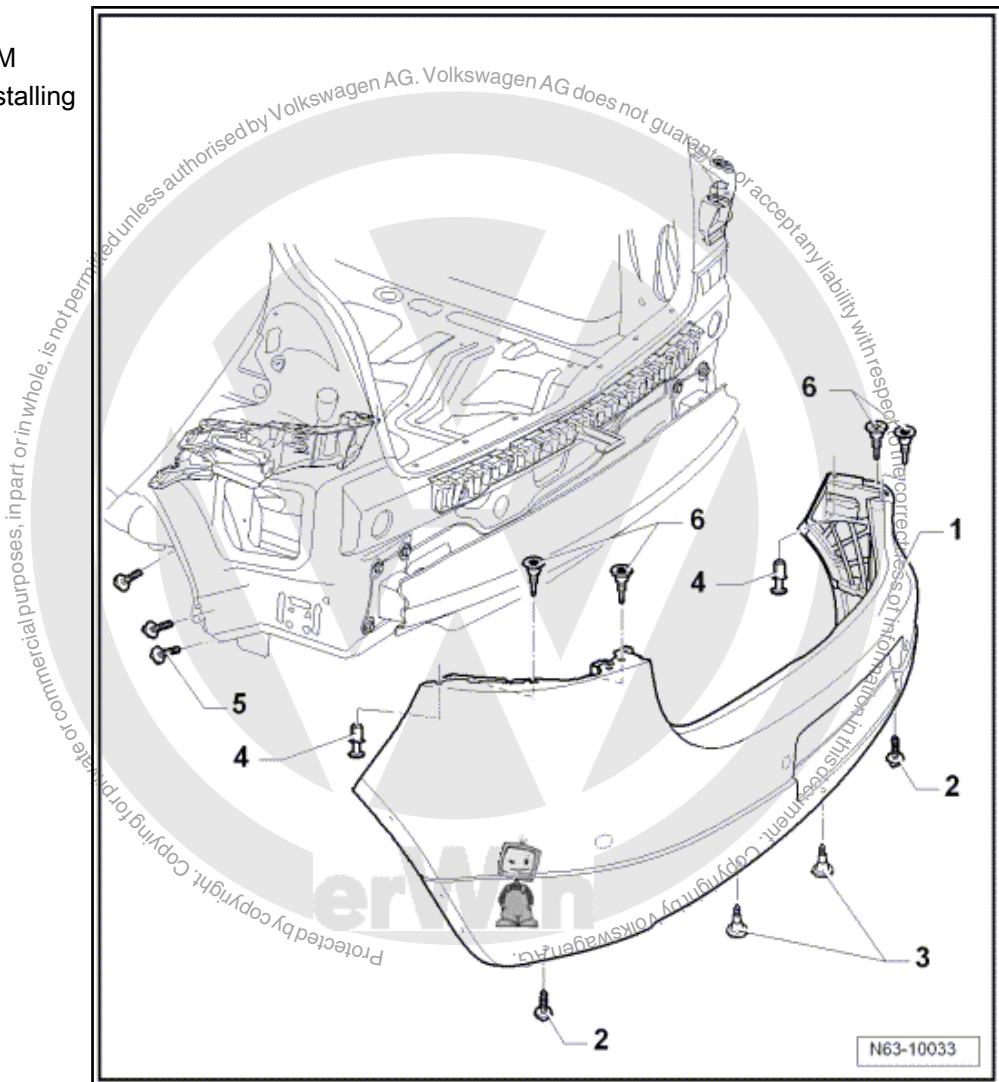

3.4 Removing and installing bumper cover



Note

The removal and installation procedures may have to be modified slightly depending on version.



3.4.1 Removing

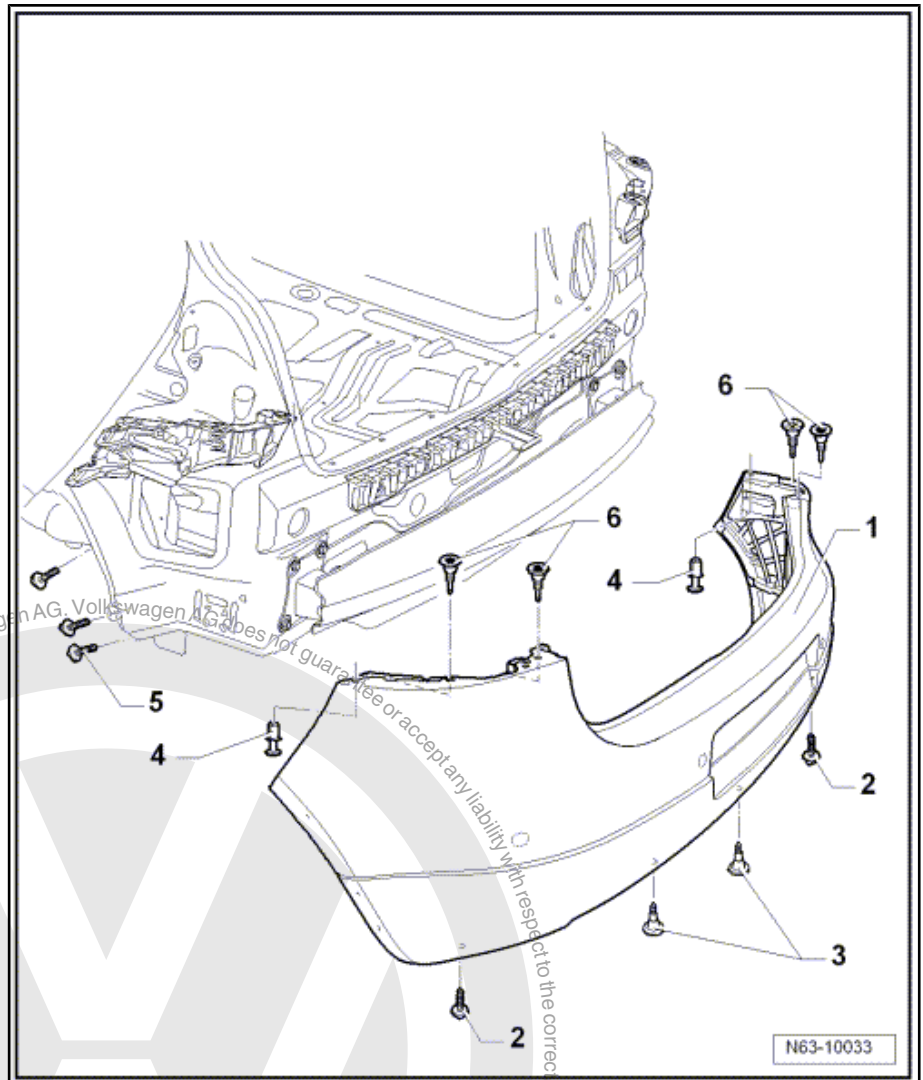

- Remove tail lights ⇒ Electrical system; Rep. Gr. 94 ; Lights, bulbs, switches - exterior; Removing and installing tail lights .
- Remove bolts -5- on left and right in area of wheel housing liner.
- Using a screwdriver lever out spreader rivet -4- on left and right in area of wheel housing liner.
- From below, remove bolts -2- and -3-.
- Remove bolts -6- from above.

Further dismantling is possible only with the help of a second mechanic.

- With help of a second mechanic pull cover -1- parallel out of guides.
- Disconnect connectors for existing electrical components, number plate light ⇒ Electrical system; Rep. Gr. 94 ; Lights, bulbs, exterior switches, number plate light and, if fitted, ⇒ Electrical system; Rep. Gr. 94 ; Lights, bulbs, exterior switches; Parking aid .



3.4.2 Installing

Installation is carried out in reverse order of removal.

- Ensure that gaps are parallel and specified dimensions are maintained => Body Repairs; Rep. Gr. 00 ; Technical data; Body gap dimensions .

3.5 Rear bumper attachments



Note

Minor differences will be encountered on removal and installing, depending on version.

1 - Cover

- Material PP/EPDM
- Removing and installing
=> [page 160](#)

2 - Number plate lights

- Qty. 2
- Removing => Electrical system; Rep. Gr. 94 ; Lights, bulbs, switches - exterior; Number plate illumination

3 - Towing eye cap

- Engaged in cover

4 - Spoiler

- Material PC/ABS
- Engaged in cover.
- Can be removed only when bumper has been removed.

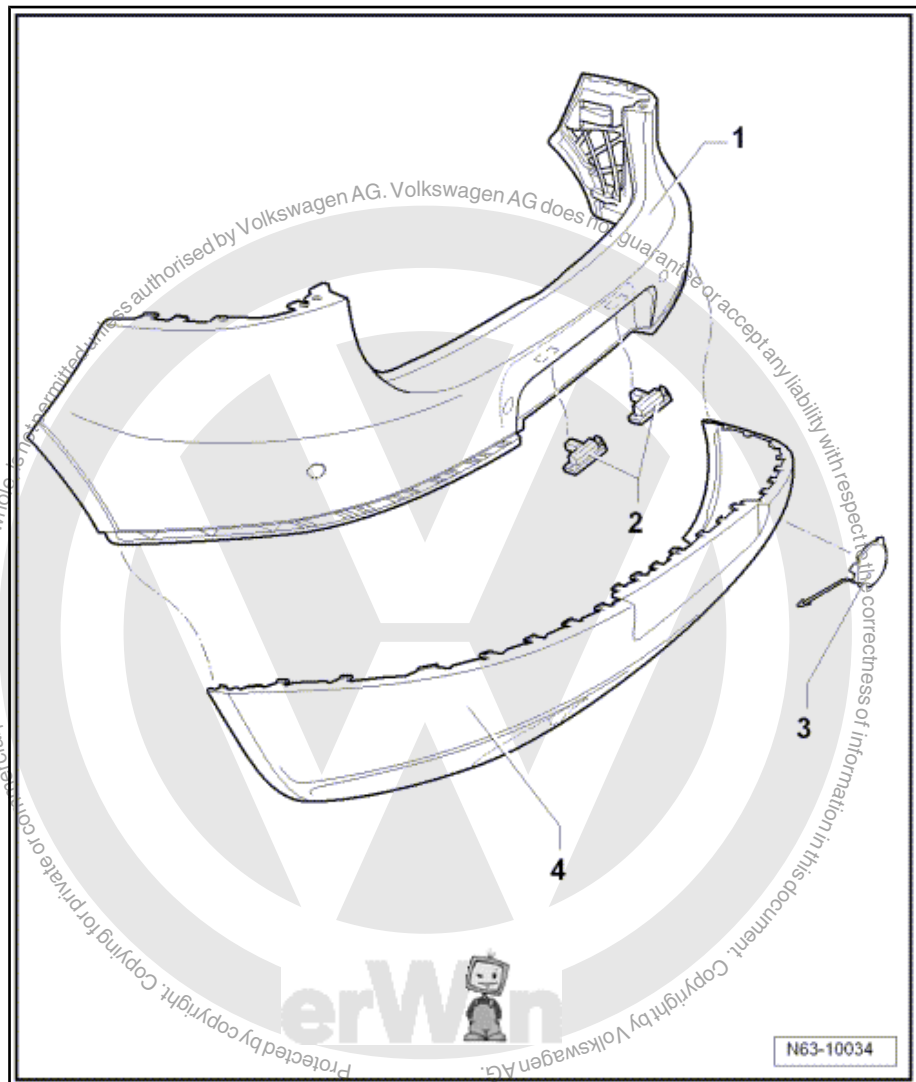



3.6 Rear bumper substructure

- 1 - Securing strip
 - Qty. 4
 - 2 Nm
- 2 - Hexagon nut
 - Qty. 4
 - 2 Nm
- 3 - Guide
 - Left and right
- 4 - Hexagon nut
 - Qty. 3 per side
 - 2 Nm
- 5 - Retaining bracket
 - Not installed on all models
- 6 - Bolt
 - Qty. 2
 - 5 Nm
- 7 - Foil
 - Left and right
 - Self-adhesive

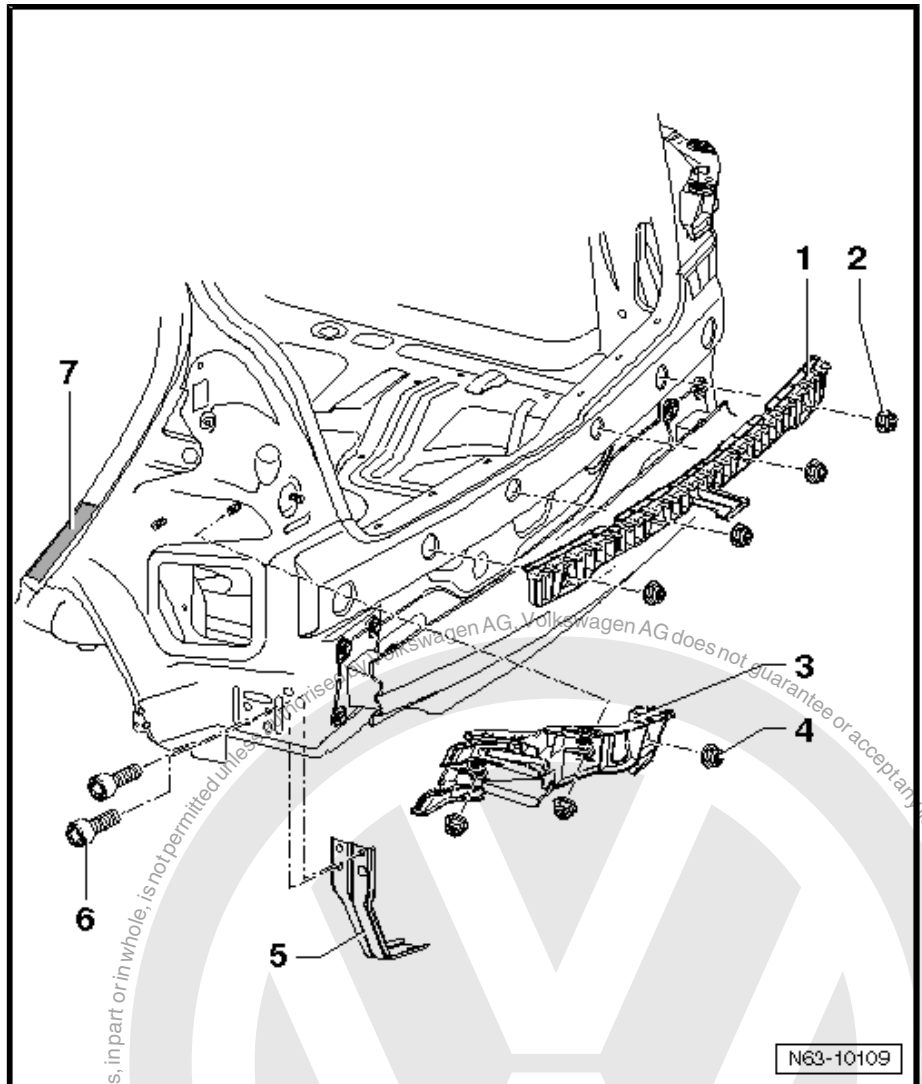



3.7 Assembly overview - bumper carrier

1 - Cross member

2 - Bolt

- Qty. 6
- 20 Nm

3 - Foam piece

- Only installed in some countries
- Self-adhesive
- Available in various shapes

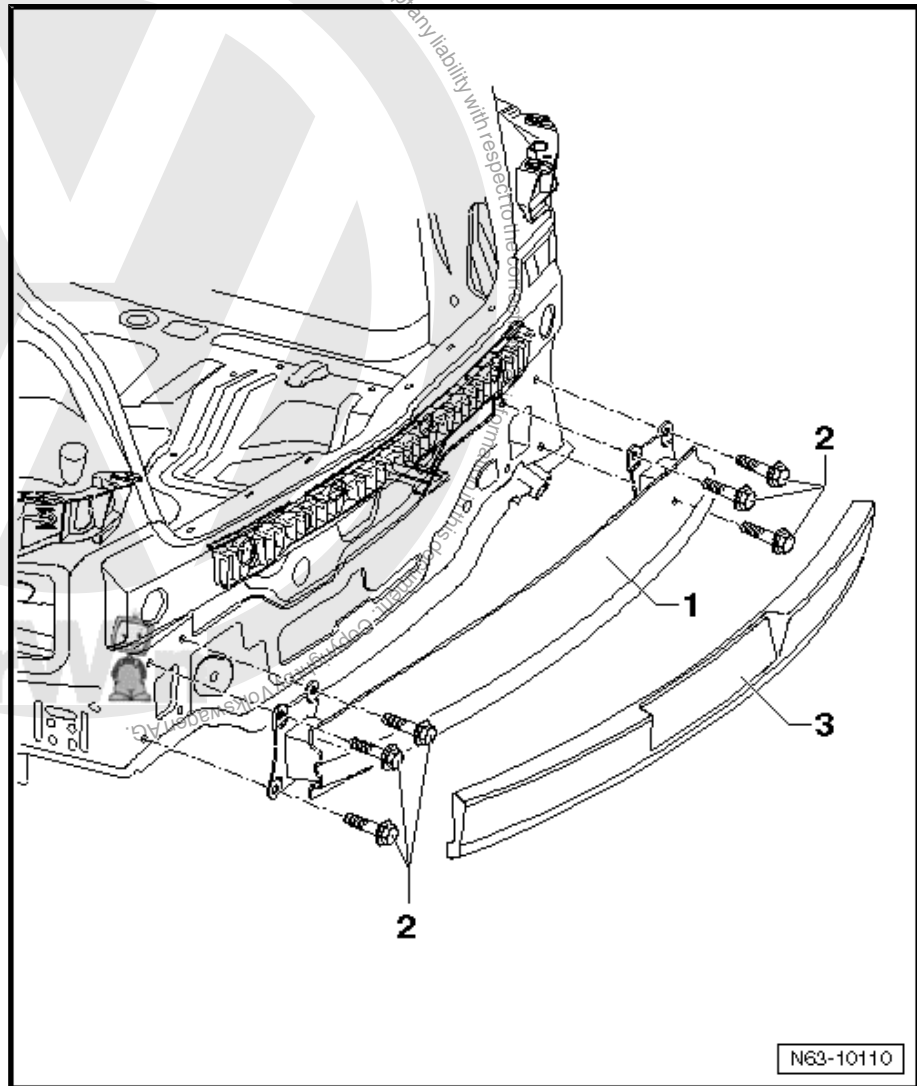

3.8 Assembly overview - towing bracket



DANGER!

The bolts -3- function as plugs and seal the passenger compartment against exhaust fumes, and must without exception be installed.



Note

- ◆ *Minor differences will be encountered on removal and installing, depending on version.*
- ◆ *The specified torques refer only to factory-installed towing brackets.*
- ◆ *Request torque specifications for other towing brackets from the manufacturers.*



1 - Towing bracket

- Towing bracket with removable ball head is shown in illustration

2 - Ball hitch

- The removable ball head is located in the left side compartment of the luggage compartment

3 - Bolt

- Plugs
- Qty. 4
- 20 Nm

4 - Bolt

- Qty. 4
- 50 Nm + turn 90° further
- Bolts must always be replaced by new ones after being undone

5 - Cover

- Material PP/EPDM
- Removing and installing
 => [page 160](#)

6 - Spring clip

- Qty. 2

7 - Cap - towing bracket

8 - Rotary fastener

- Qty. 2

9 - Retaining disc

- Qty. 2

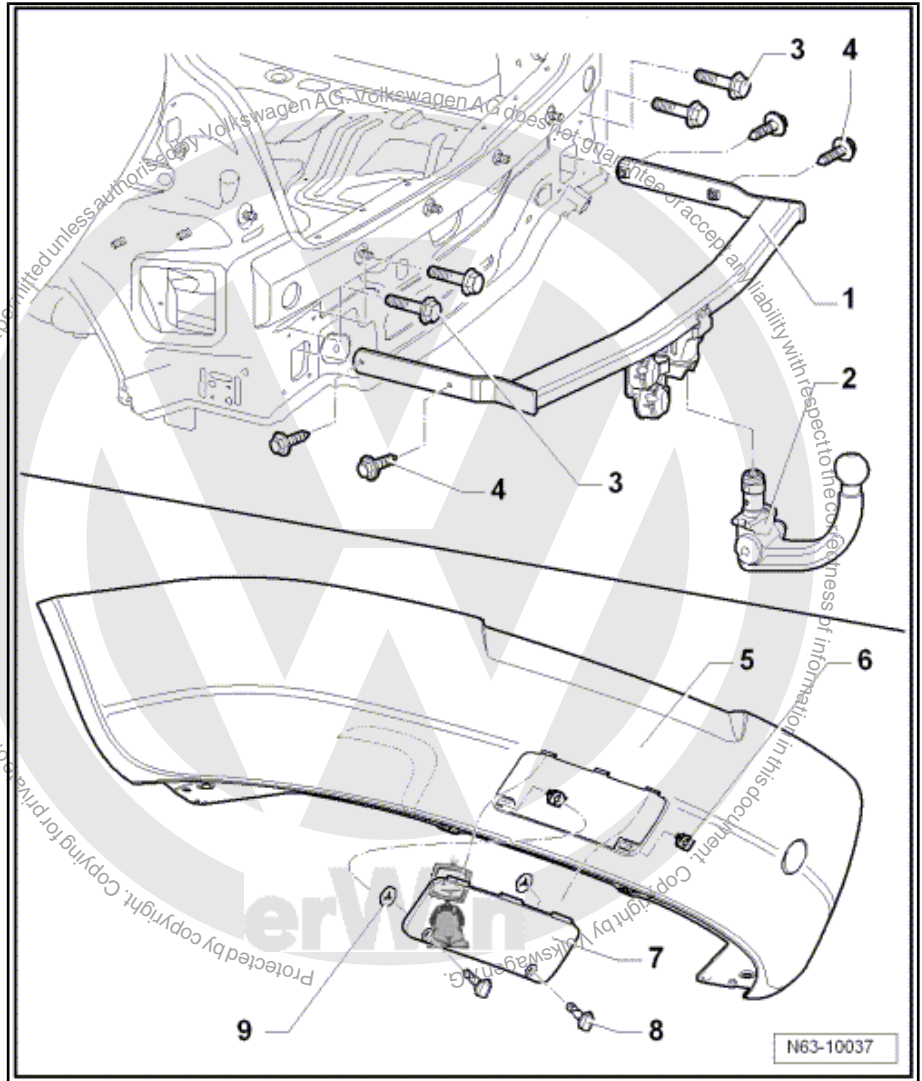



4 Rear bumper for R32 and GTI special models

4.1 Tools

Special tools and workshop equipment required

- ◆ Torque wrench -V.A.G 1783-

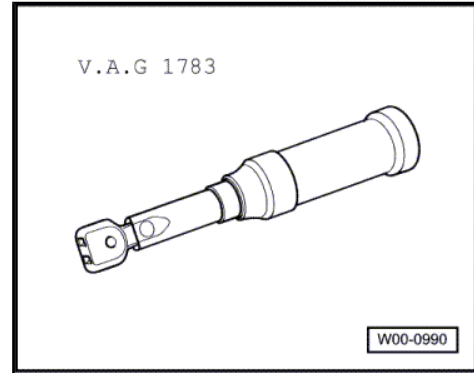

- ◆ Torque wrench -V.A.G 1332-

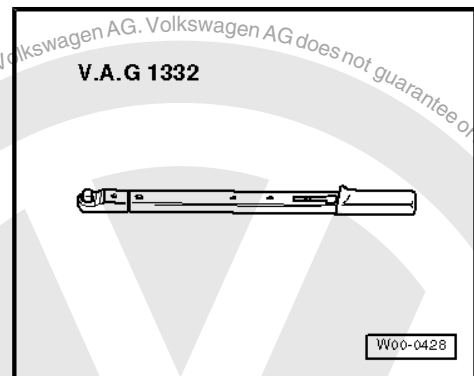

4.2 Repairing bumper cover



Note

If bumper cover is damaged, determine whether plastic can be repaired before renewing bumper

Details can be found under: ⇒ General Information; Body Repairs, General Body Repairs ; Work procedures; Plastic repair procedures .



4.3 Assembly overview - bumper cover for R32

i Note

Minor differences may be encountered in the assembly overview depending on version.

1 - Cover

- With various forms for number plate
- Material PP/EPDM
- Removing and installing
 ⇒ [page 167](#)

2 - Bolt

- Qty. 2
- 5 Nm

3 - Bolt

- Qty. 3
- 5 Nm

4 - Bolt

- Qty. 4 per side.
- 2 Nm

5 - Bolt

- Qty. 4
- 5 Nm

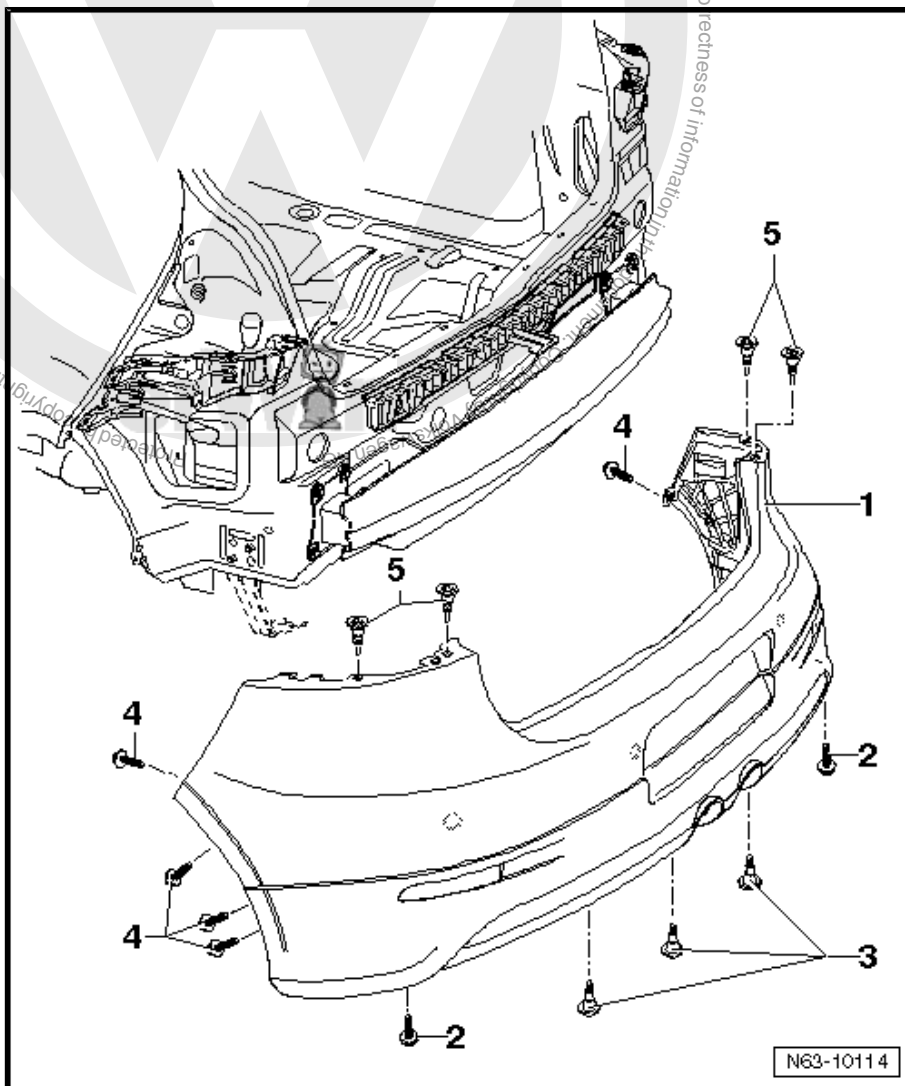

4.4 Removing and installing bumper cover for R32

i Note

The removal and installation procedures may have to be modified slightly depending on version.



4.4.1 Removing

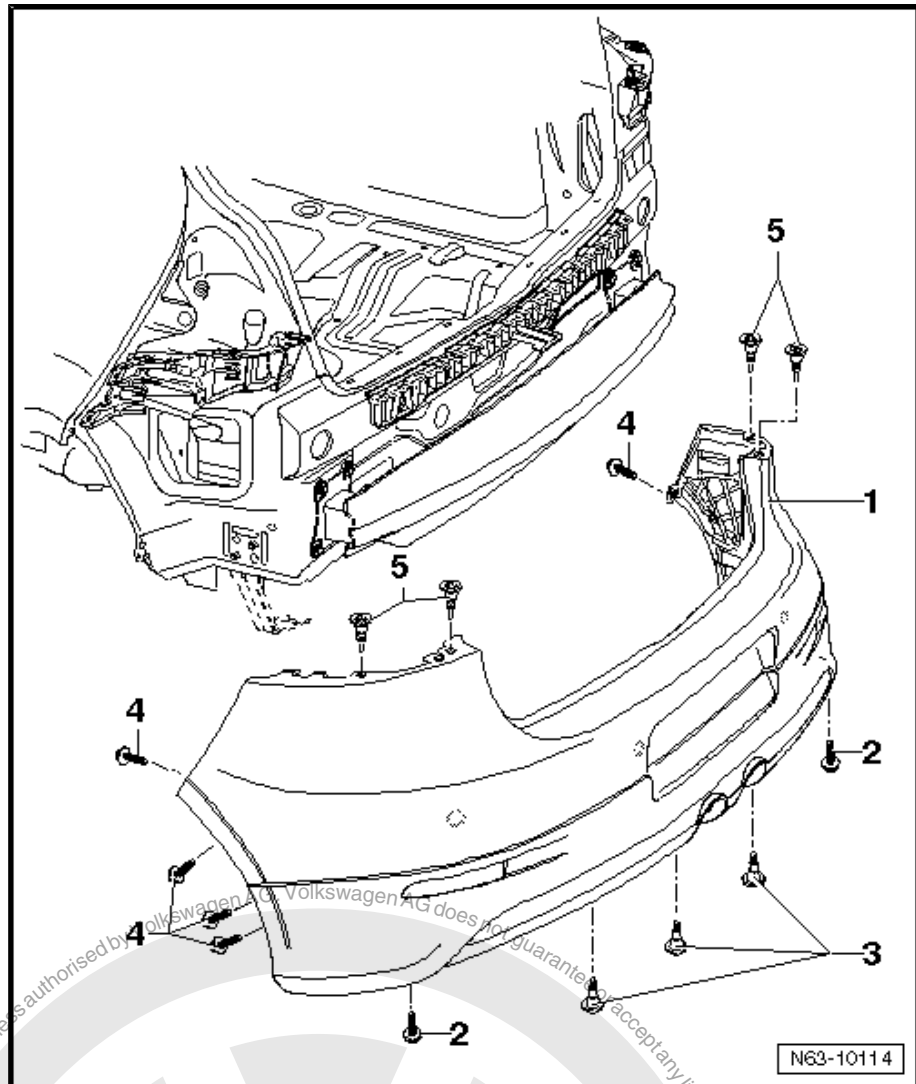

- Remove tail lights ⇒ Electrical system; Rep. Gr. 94 ; Lights, bulbs, switches - exterior; Removing and installing tail lights .
- Remove bolts -4- on left and right in area of wheel housing liner.
- From below, remove bolts -2- and -3-.
- Remove bolts -5- from above.

Further dismantling is possible only with the help of a second mechanic.

- With help of a second mechanic pull cover -1- parallel out of guides.
- Disconnect connectors for existing electrical components, number plate light ⇒ Electrical system; Rep. Gr. 94 ; Lights, bulbs, exterior switches; number plate light and, if fitted, ⇒ Electrical system; Rep. Gr. 94 ; Lights, bulbs, exterior switches; Parking aid .

4.4.2 Installing

Installation is carried out in reverse order of removal.



- Ensure that gaps are parallel and specified dimensions are maintained ⇒ Body Repairs; Rep. Gr. 00 ; Technical data; Body gap dimensions .

4.5 Rear bumper attachments for R32



Note

Minor differences will be encountered on removal and installing, depending on version.

1 - Cover

- With various forms for number plate
- Material PP/EPDM
- Removing and installing ⇒ [page 167](#)

2 - Number plate lights

- Qty. 2
- Removing ⇒ Electrical system; Rep. Gr. 94 ; Lights, bulbs, switches - exterior; Number plate illumination

3 - Right fitting bracket

4 - Spoiler

- With various forms for number plate
- Material PC/ABS
- Engaged in cover
- Can be removed only when bumper has been removed

5 - Rear right reflector

- Engaged in spoiler
- Can be removed only when bumper has been removed

6 - Trim

- Material PC/ABS
- Engaged in cover
- Can be removed only when bumper has been removed

7 - Towing eye cap

- Engaged in cover

8 - Rear left reflector

- Engaged in spoiler
- Can be removed only when bumper has been removed

9 - Left fitting bracket

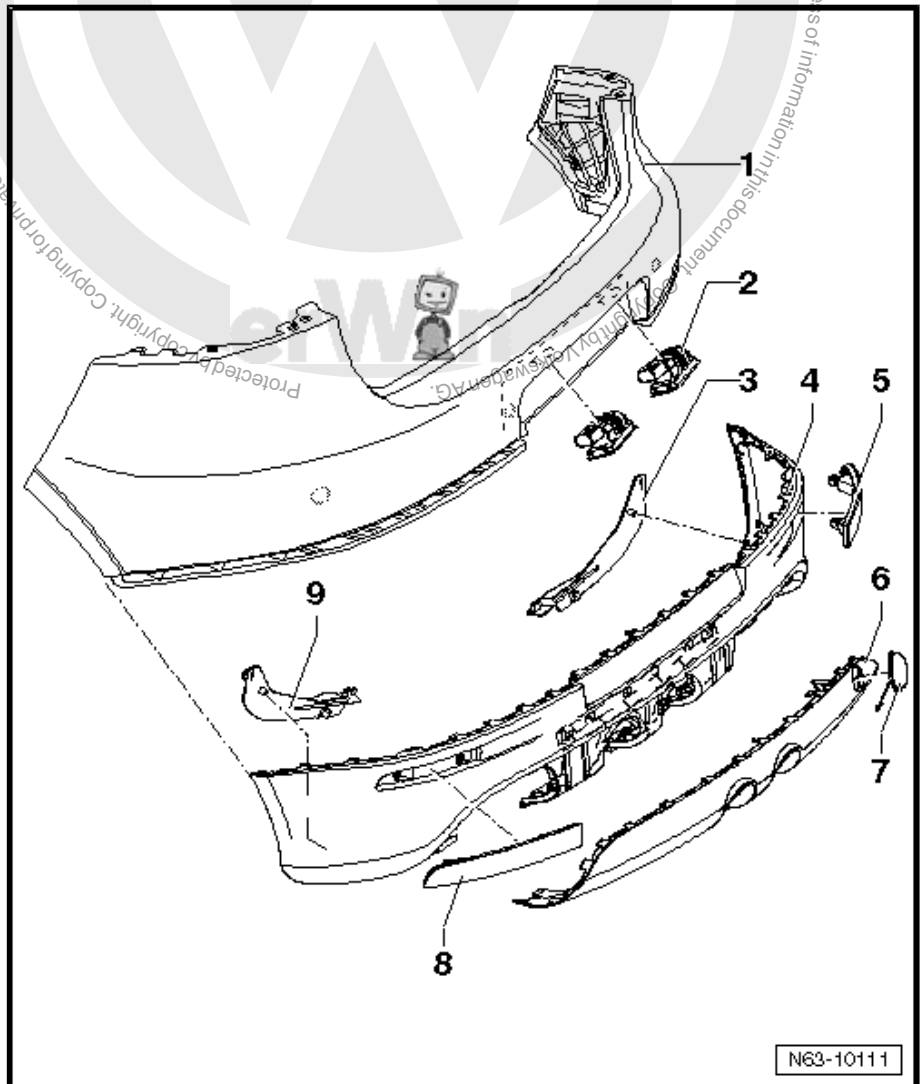



4.6 Assembly overview - rear bumper cover for GTI special models



Note

Minor differences may be encountered in the assembly overview depending on version.

1 - Cover

- Material: PP/EPDM PU-RIM
- Removing and installing
⇒ [page 170](#)

2 - Bolt

- Qty. 2
- 2 Nm

3 - Bolt

- Qty. 2
- 5 Nm

4 - Bolt

- Qty. 4 per side.
- 2 Nm

5 - Bolt

- Qty. 2 per side.
- 5 Nm

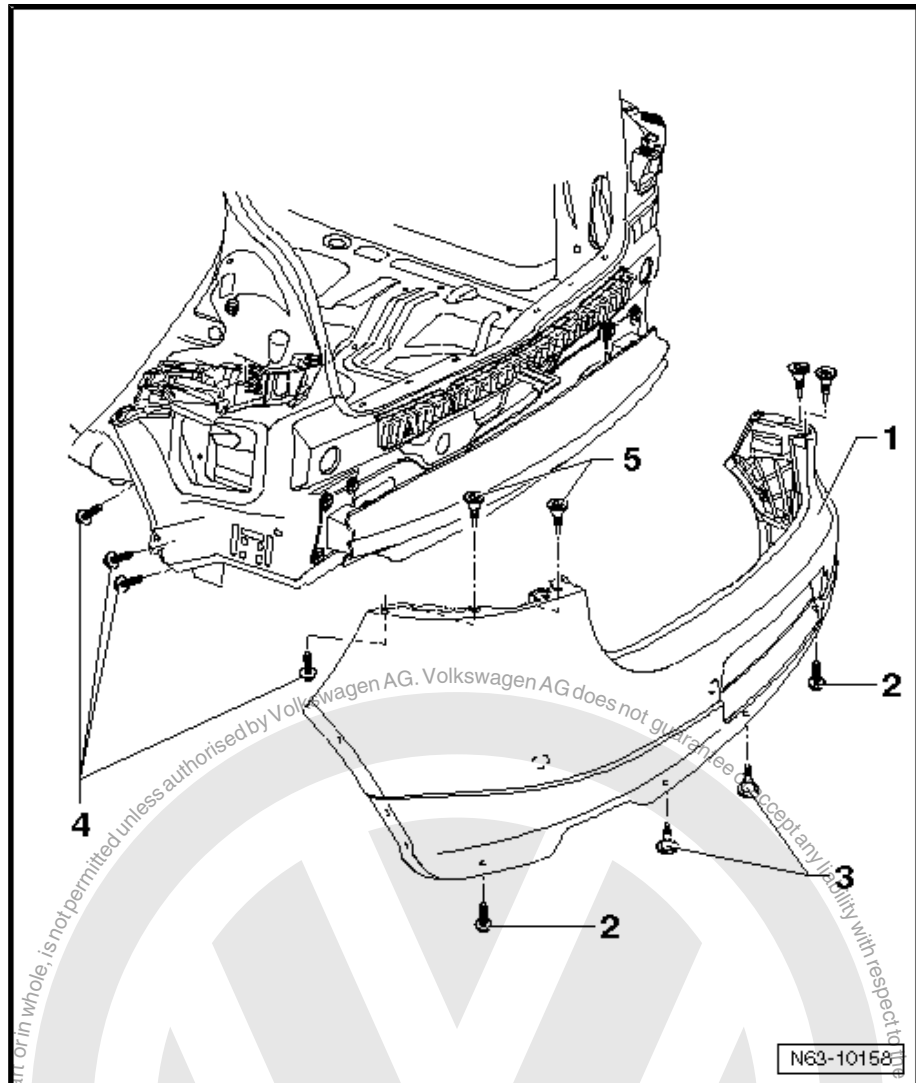

4.7 Removing and installing rear bumper cover for GTI special models



Note

The removal and installation procedures may have to be modified slightly depending on version.



4.7.1 Removing

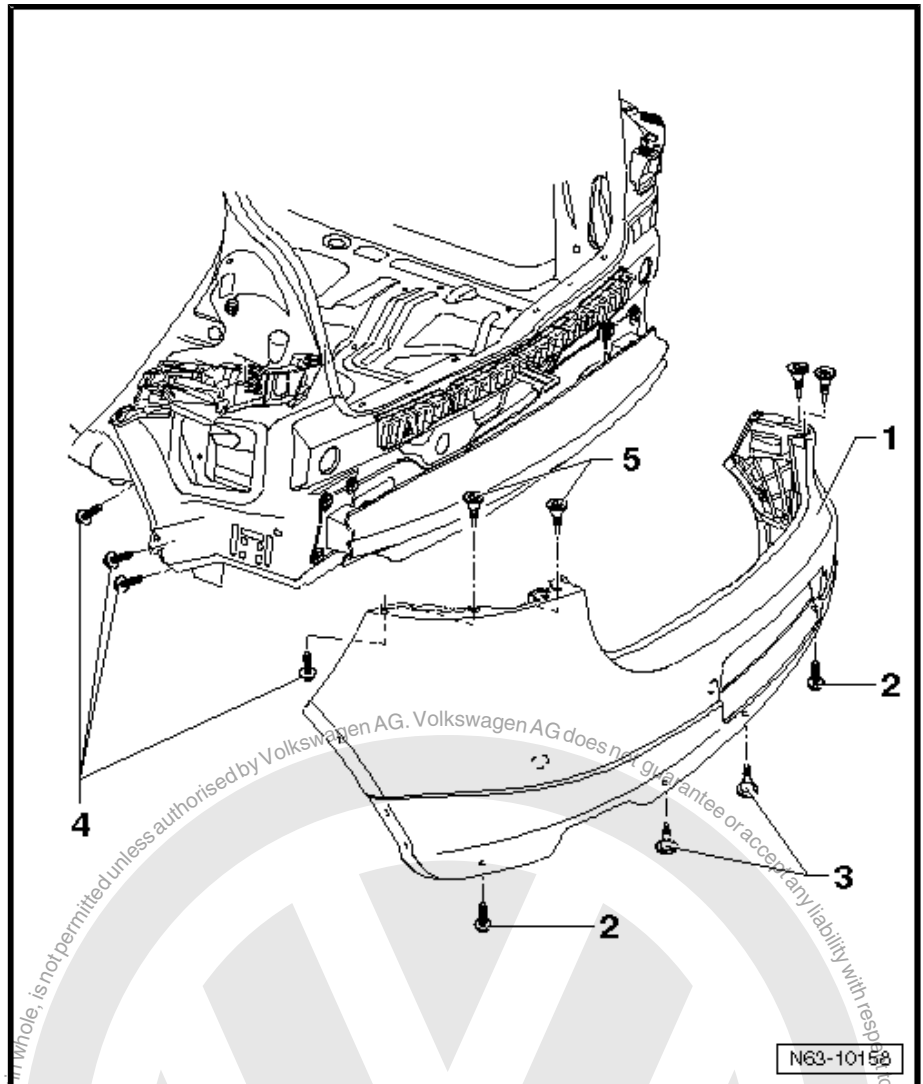

- Remove tail lights ⇒ Electrical system; Rep. Gr. 94 ; Lights, bulbs, switches - exterior; Removing and installing tail lights .
- Remove bolts -4- on left and right in area of wheel housing liner.
- From below, remove bolts -2- and -3-.
- Unscrew bolts -5- from above on left and right beneath tail lights.

Further dismantling requires the help of a second mechanic.

- With help of a second mechanic pull cover -1- parallel out of guides.
- Separate connectors for existing electrical components of number plate light ⇒ Electrical system; Rep. Gr. 94 ; Lights, bulbs, switches - exterior; Number plate lights and, if fitted, ⇒ Electrical system; Rep. Gr. 94 ; Lights, bulbs, switches - exterior; Parking aid .

4.7.2 Installing

Installation is carried out in reverse order of removal.



- Ensure that gaps are parallel and specified dimensions are maintained => Body Repairs; Rep. Gr. 00 ; Technical data; Body panel gaps/shut lines .

4.8 Rear bumper attachments for GTI special models



Note

Minor differences will be encountered on removal and installing, depending on version.

1 - Cover

- Material: PP/EPDM PU-RIM
- Removing and installing:

2 - Number plate lights

- Qty. 2
- Removing:
 - => Electrical system; Rep. Gr. 94 ; Lights, bulbs, switches - exterior; Number plate lights .

3 - Towing eye cap

- Engaged in cover.

4 - Spoiler

- Material: PU-RIM
- Engaged in cover
- Can be removed only when bumper has been removed

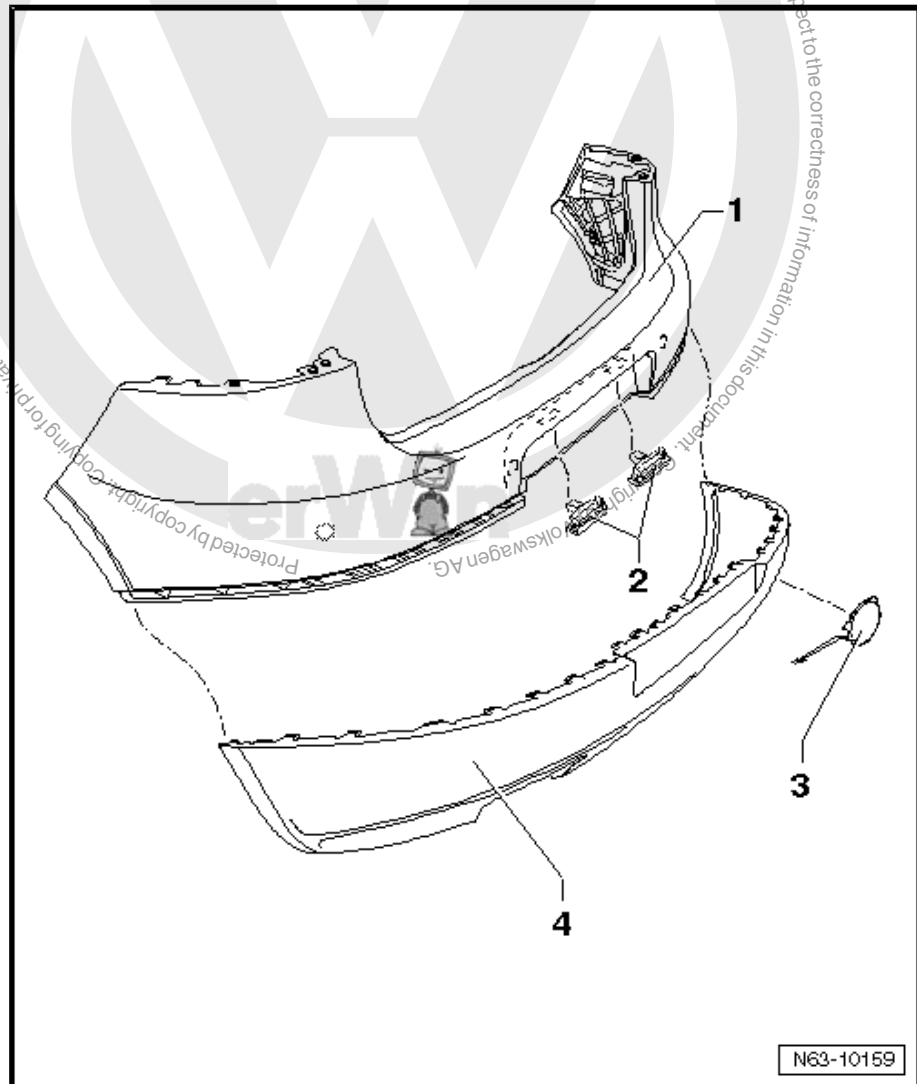



4.9 Rear bumper substructure

1 - Securing strip

2 - Hexagon nut

- Qty. 4
- 2 Nm

3 - Guide

- Left and right

4 - Hexagon nut

- Qty. 3 per side
- 2 Nm

5 - Retaining bracket

- Not installed on all models

6 - Bolt

- Qty. 2
- 5 Nm

7 - Foil

- Left and right
- Self-adhesive

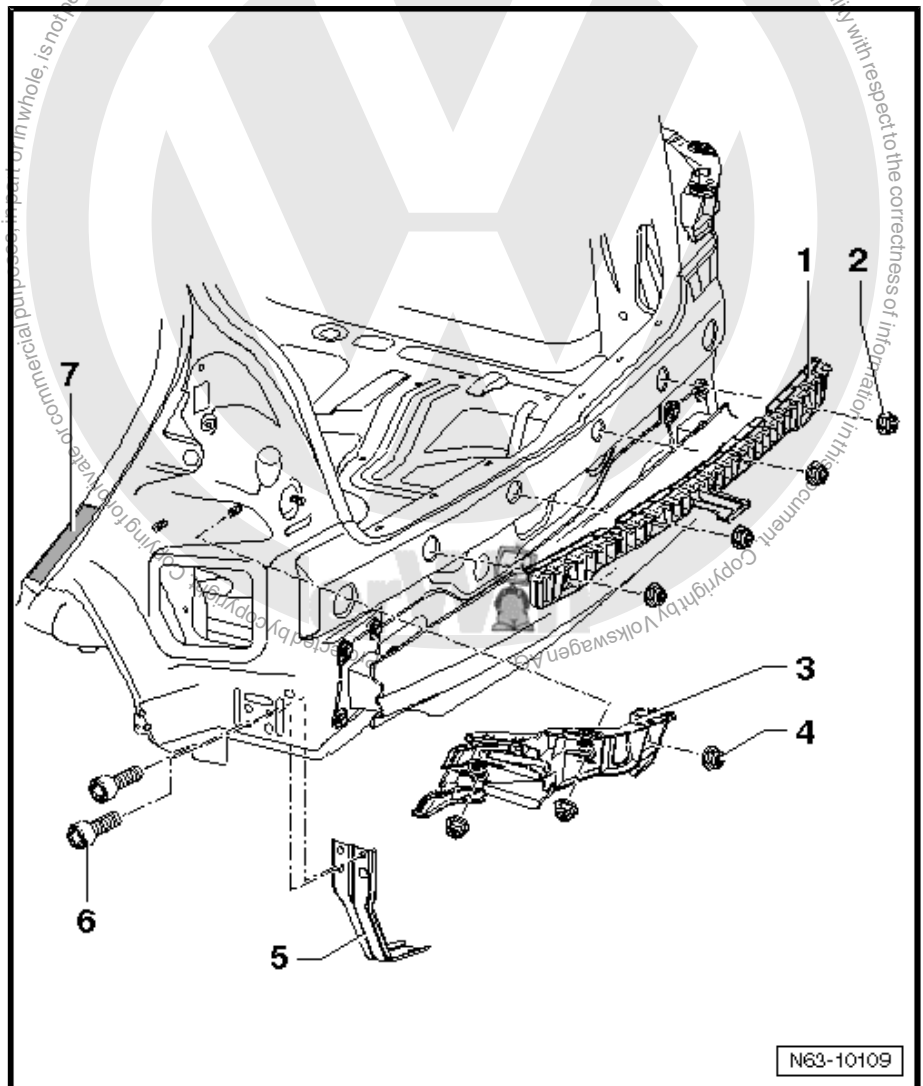



4.10 Assembly overview - bumper carrier



Note

Minor differences will be encountered on removal and installing, depending on version.

1 - Cross member

2 - Bolt

- Qty. 6
- 20 Nm

3 - Foam piece

- Only installed in some countries
- Self-adhesive
- Available in various shapes

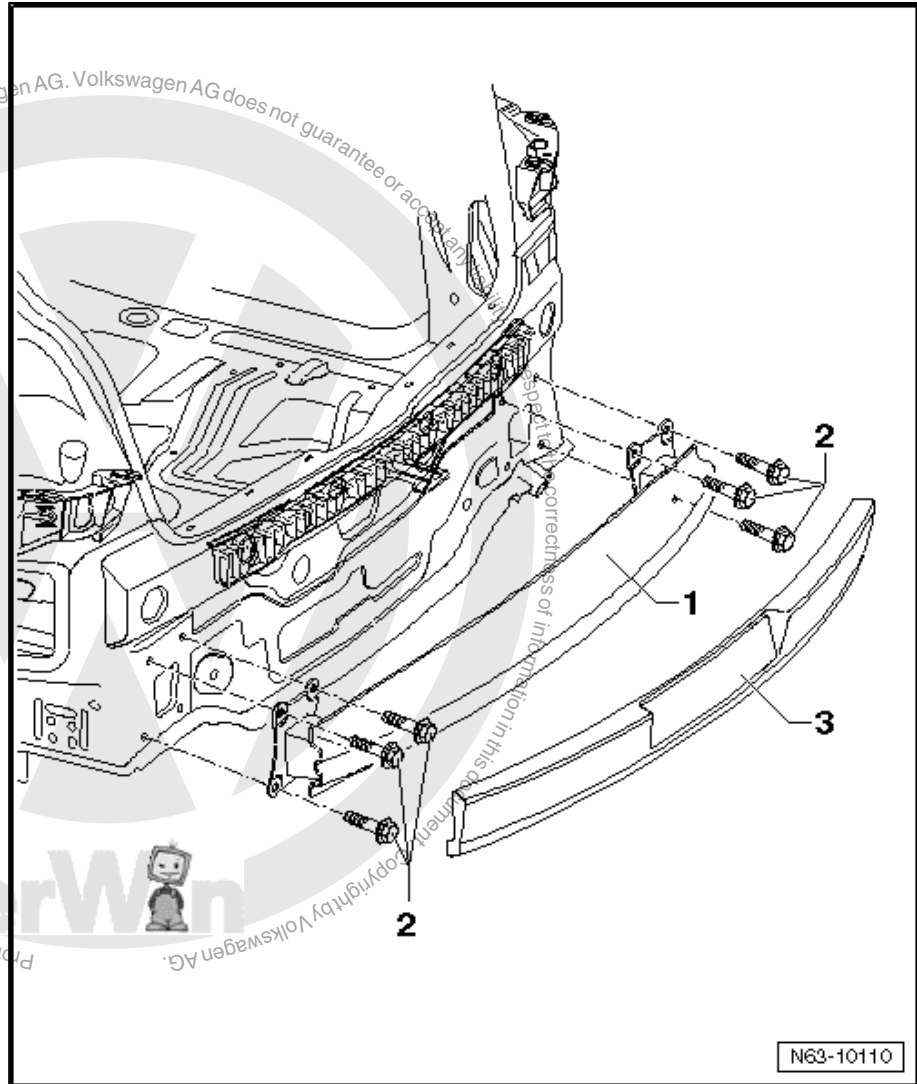



64 – Glazing

1 Flush bonded windows

1.1 Tools

Special tools and workshop equipment required

- ◆ Removal kit for flush bonded windows -V.A.G 1474 A-
- ◆ Suction lifter -V.A.G 1344-
- ◆ Cutting tool -V.A.G 1351-
- ◆ Windscreen removal kit -V.A.G 1755-
- ◆ Hand-cartridge gun -V.A.G 1628-
- ◆ Cartridge heater -V.A.G 1939-

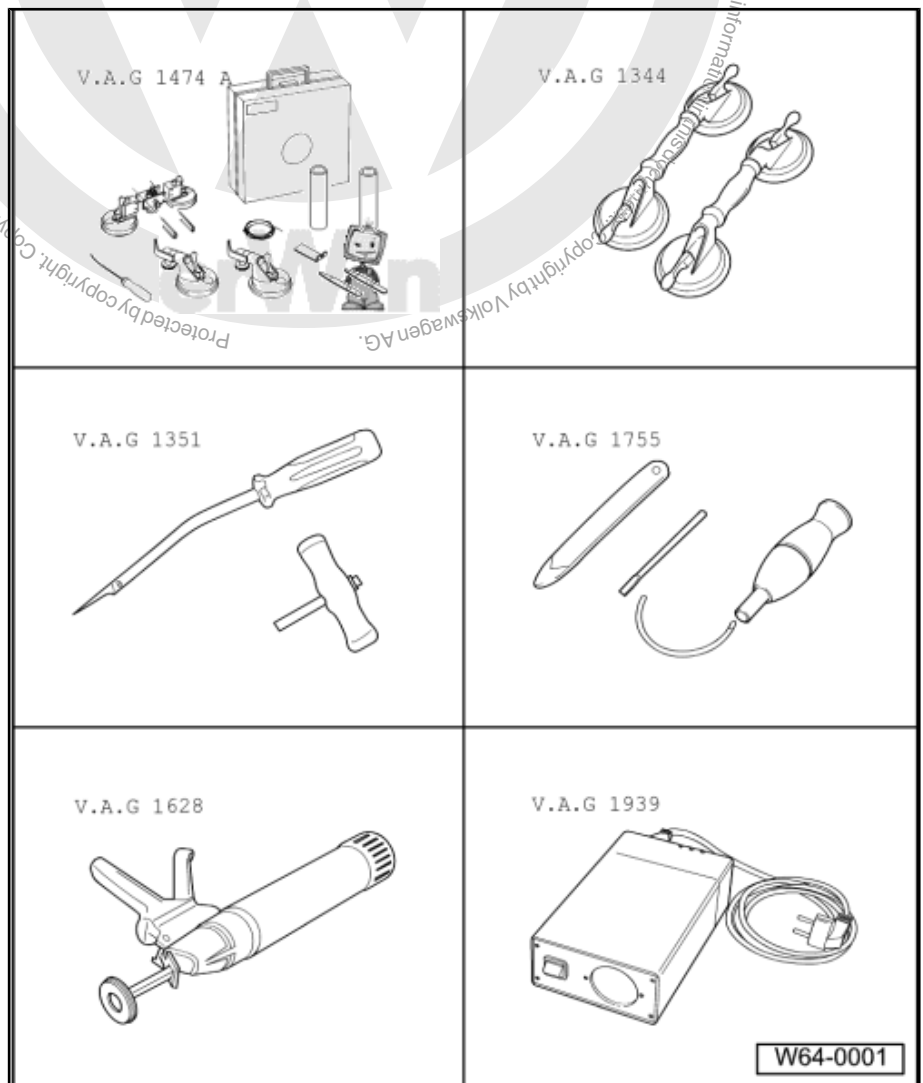

- ◆ Electric cutter -V.A.G 1561 A-
- ◆ Cutting blade -V.A.G 1561/2-



- ◆ Scraping blade -V.A.G 1561/8-
- ◆ Cutting blade -V.A.G 1561/10-
- ◆ Cutting blade -V.A.G 1561/19-
- ◆ Double cartridge gun -VAS 5237-

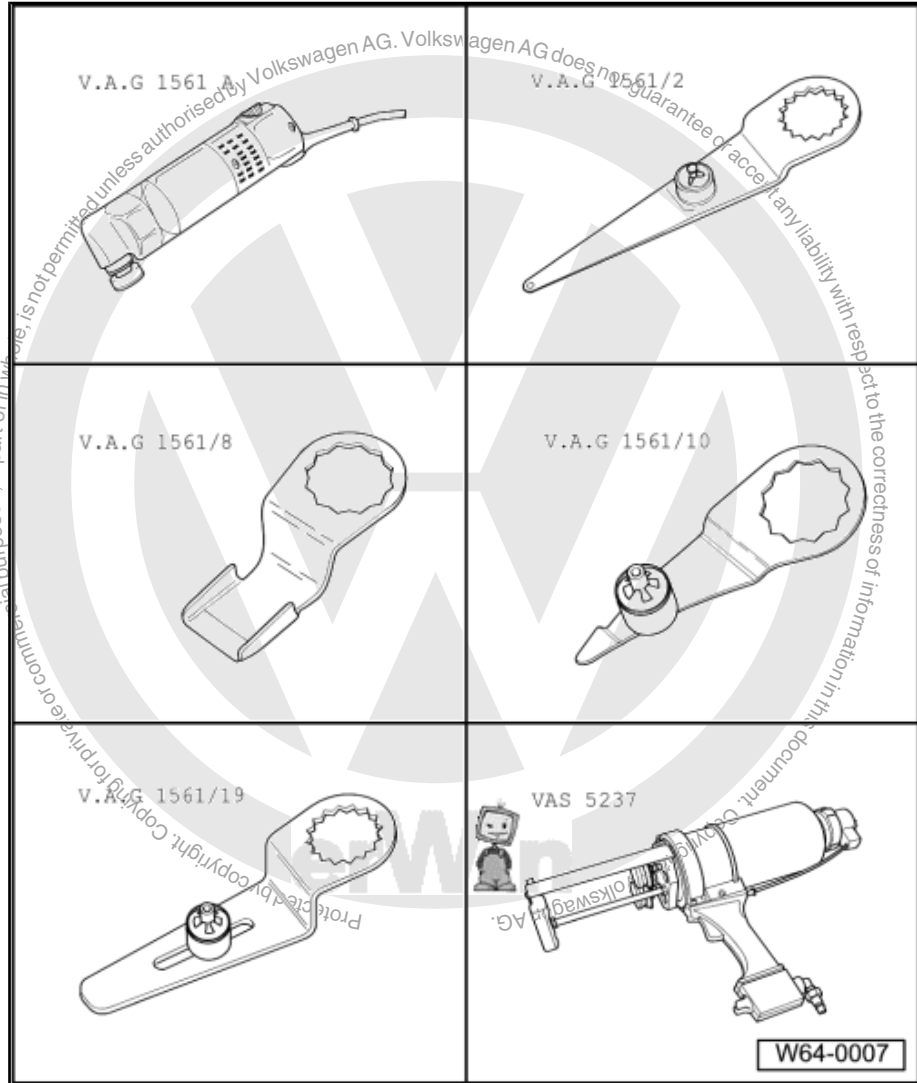



1.2 Materials

◆ 2K window adhesive	DA 004 600 A2 ¹⁰⁾ ¹²⁾
◆ 1K window adhesive	DH 009 100 03 ¹³⁾ ¹¹⁾
◆ Activator	D 181 801 A1 ⁹⁾
◆ Glass primer/paint primer	D 009 200 02 ⁹⁾
◆ Cleaning solution	D 009 401 04 ⁹⁾
◆ Primer applicator	D 009 500 25 ⁹⁾
◆ Adhesive remover	D 002 000 10 ⁹⁾
◆ Cutting cord	357 853 999

9) Observe instructions for use on the information sheet provided by the manufacturer.

10) Observe minimum curing period: ⇒ [page 191](#)

11) Heat, according to manufacturers' instructions, using cartridge heater -V.A.G 1939- .

12) Double cartridge gun -VAS 5237- must be used to apply these materials.

13) Small cartridge 110 ml for sealing and/or when a 400 ml cartridge alone is not sufficient.

1.3 Repairing windscreen



Note

Before renewing windscreen, explore possibilities of repairing damage to glass.

Description can be found under ⇒ General Information; Body Repairs, General Body Repairs; Work procedures; Glass repair .





1.4 Assembly overview - windscreen

1 - Windscreen

- Removing ⇒ [page 182](#)
- Installing ⇒ [page 182](#)

2 - Windscreen adjuster

- 443 845 631 A

3 - Plenum chamber cover

- Must be removed from windscreen seal by hand only
- Removing ⇒ [page 180](#)
- Installing ⇒ [page 181](#)

4 - Windscreen seal

- Integral part of windscreen

5 - Spacing lip

- Integral part of windscreen

6 - PUR adhesive sealant

- Cross section of bead: width = 6.5 mm, height = 10 mm (including residual material on window glass and window flange)
- Minimum curing period ⇒ [page 191](#)

7 - Water deflector

- Removing ⇒ [page 242](#)
- Installing ⇒ [page 243](#)

8 - Sealing lip

- If sealing lip is damaged when it is cut out, a new windscreen must be installed

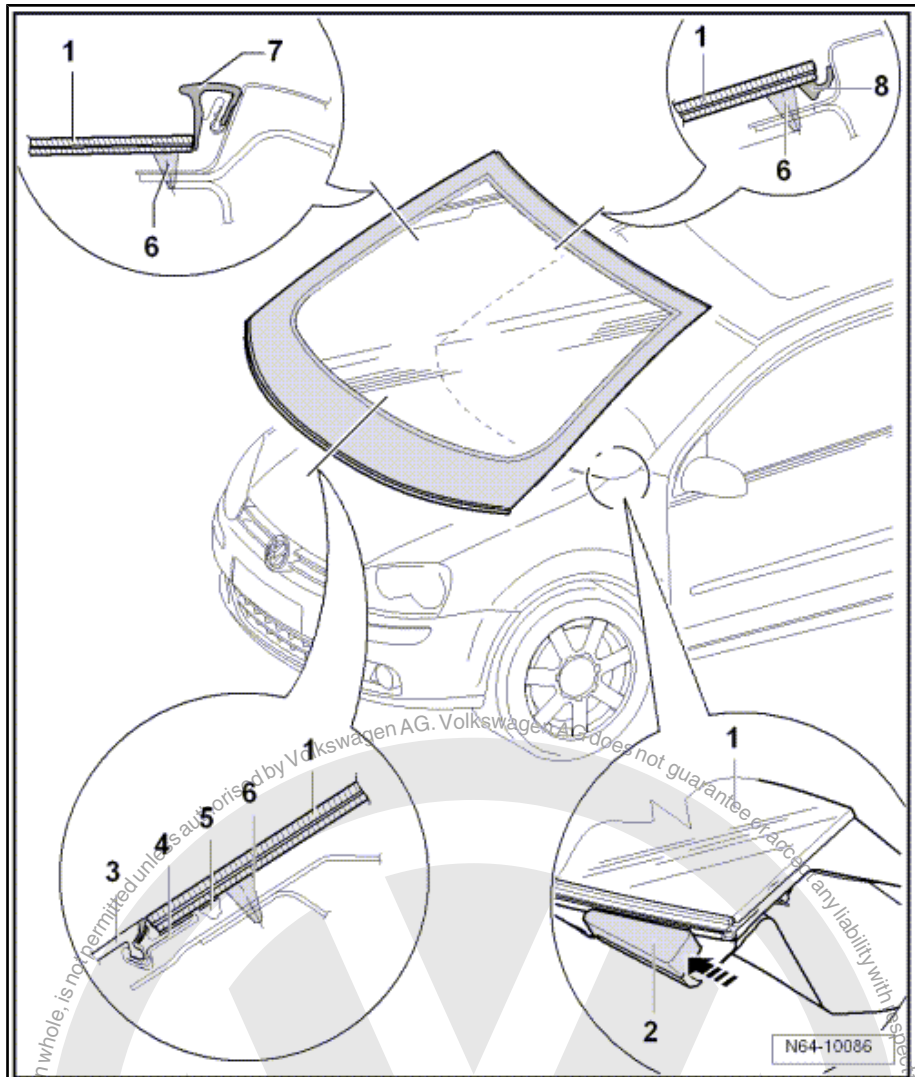



1.5 Assembly overview - plenum chamber cover

1 - Plenum chamber cover

- Must be removed from windscreen seal by hand only
- Removing ⇒ [page 180](#)
- Installing ⇒ [page 181](#)

2 - Plenum chamber bulkhead

3 - Windscreen

4 - Plenum chamber seal

5 - Windscreen seal

- Integral part of windscreen

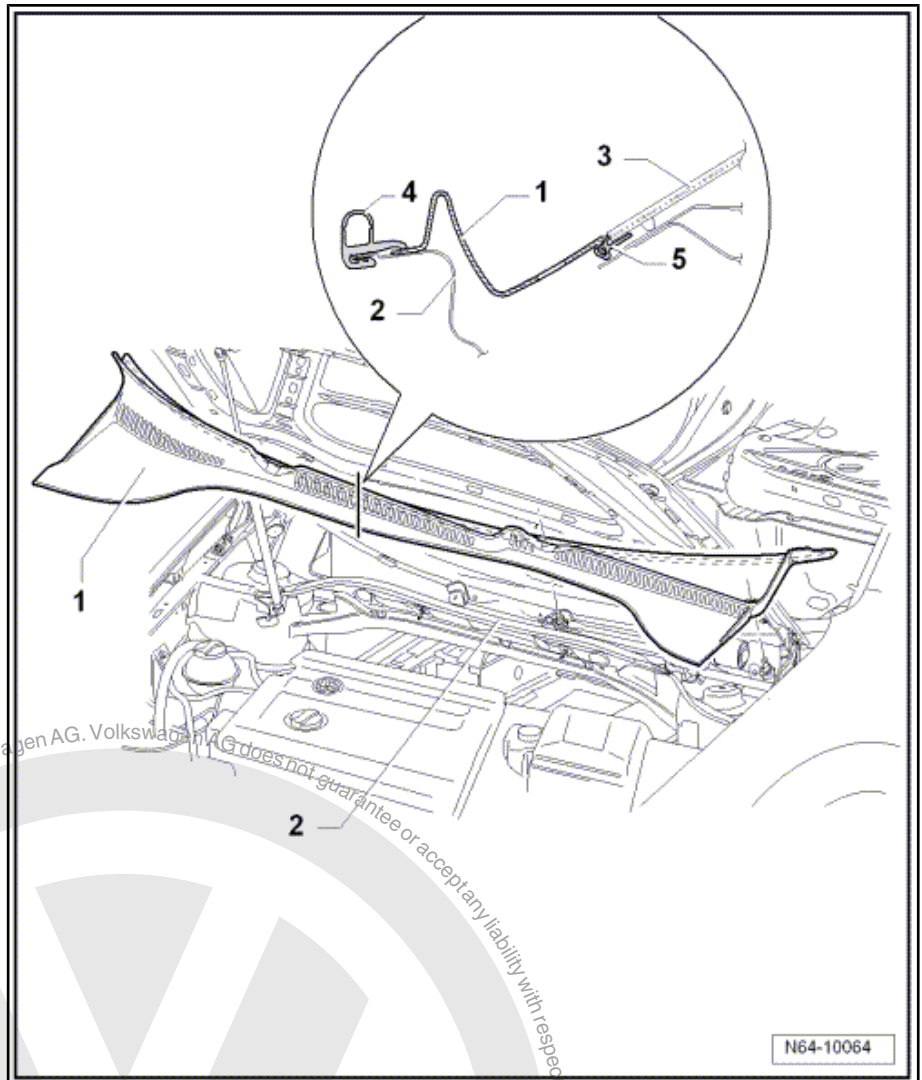

Protected by copyright. Copying for private or commercial purposes, in part or in whole, is not permitted unless authorised by Volkswagen AG. Volkswagen AG does not guarantee or accept any liability with respect to the correctness of information in this document.

erWin



1.5.1 Removing plenum chamber cover

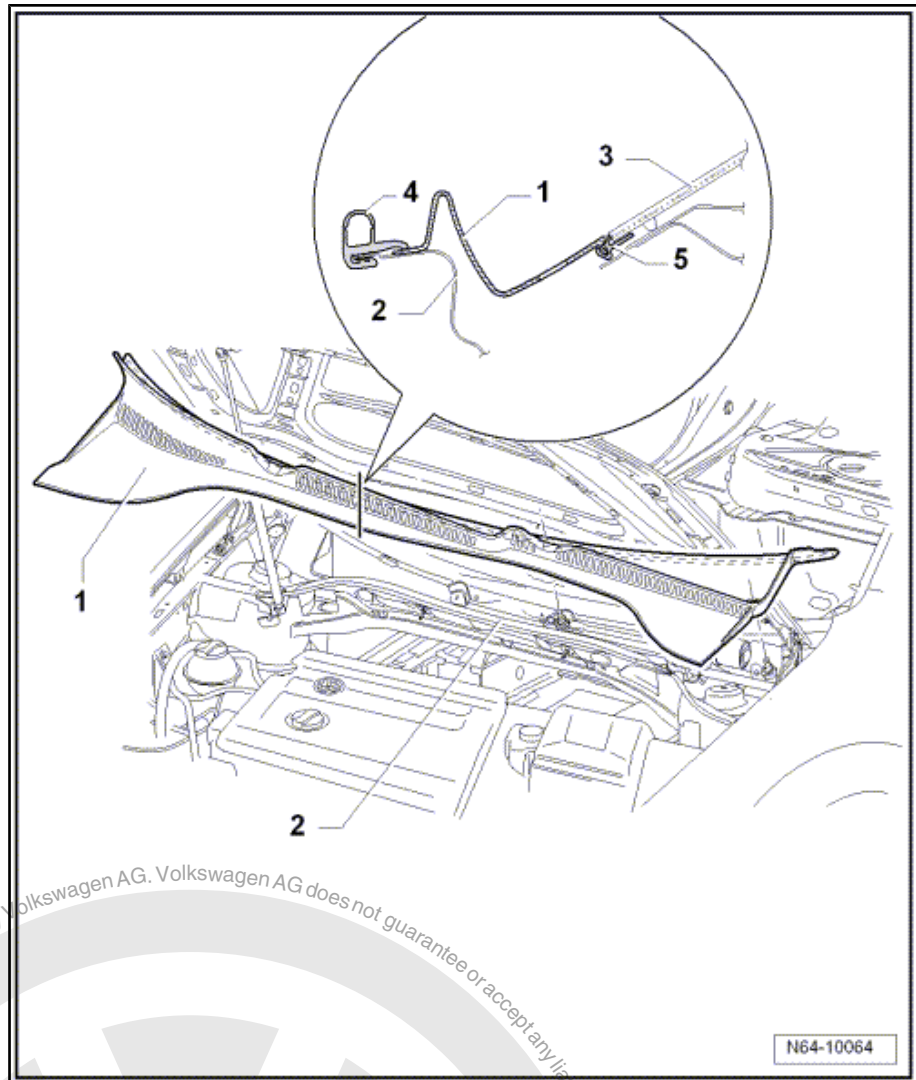

- Unbolt wiper arms ⇒ Electrical system; Rep. Gr. 92 ; Windscreen wiper system; Removing and installing windscreen wiper system; Removing and installing wiper arms .



WARNING

The plenum chamber cover must not be levered off with a tool (wedge). The windscreen will be damaged and can later crack.

- Pull plenum chamber seal -4- off over entire length of plenum chamber bulkhead -2-.
- Beginning on right, carefully pull plenum chamber cover -1- upwards out of windscreen seal -5-.



1.5.2 Installing plenum chamber cover

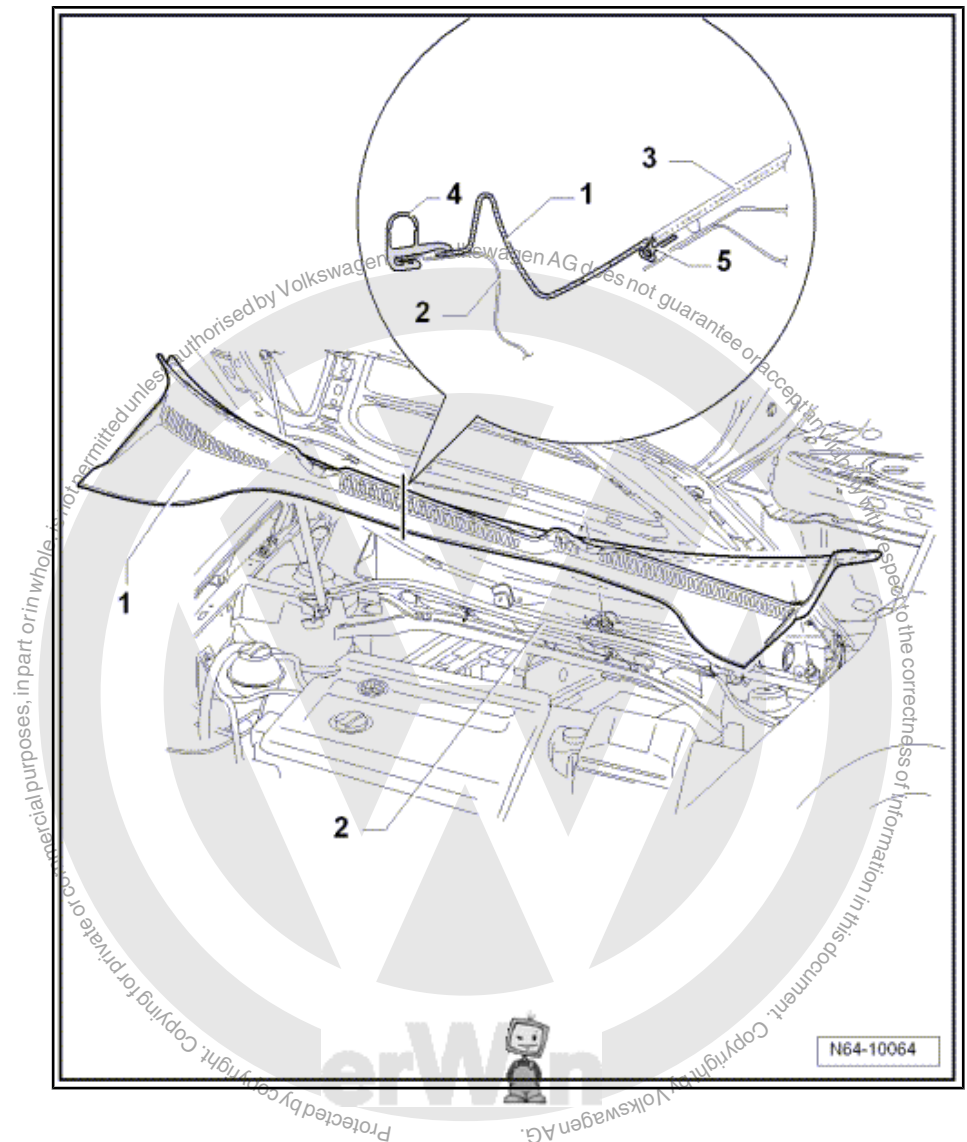

WARNING

Striking the plenum chamber cover can cause cracks in the windscreen.

- Spray windscreen seal -5- with a soapy solution so that plenum chamber cover -1- is easier to press on.
- Place the plenum chamber cover -1- on the windscreen seal -5- and engage with the windscreen seal -5- starting in the middle and applying light pressure.
- Install plenum chamber seal -4- and windscreen wiper.



Note

An insert is installed in windscreen seal of new windscreens. Remove this insert before installing plenum chamber cover.



1.6 Removing windscreen

- Remove A-pillar trims => General body repairs, interior; Rep. Gr. 70 ; Trims, insulation; Pillars and side trims .
- Remove left and right sun visors => General body repairs, interior; Rep. Gr. 68 ; Interior equipment; Compartments, covers and trims .
- Remove interior mirror => General body repairs, interior; Rep. Gr. 68 ; Interior equipment; Interior mirror .
- Remove water deflector strips on left and right => [page 242](#)
- Slide cover -V.A.G 1474/8- between windscreen -1- and dash panel.
- Thrust awl -V.A.G 1474/2- -2- through adhesive bead.
- Pull cutting cord -3- through adhesive sealing material into inside of vehicle using awl -V.A.G 1474/2- -2-.

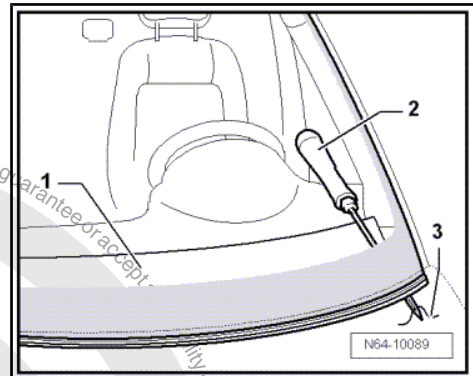

- Secure inside end of cutting cord against falling out using pull handle -V.A.G 1351/1- -3-.
- Loosen sealing lip in upper area of windscreen with a plastic wedge and spray in cleaning solution D 009 401 04 (as substitute for lubricant).
- Place cutting cord -2- using small tube -1- in upper area of window.
- If gap is too small, guide cutting cord on outside and push under lip with a plastic wedge.
- Lay cutting cord -2- around window and guide second end of cord inwards into interior.
- Ensure that cutting cord -2- lies under window in corners.

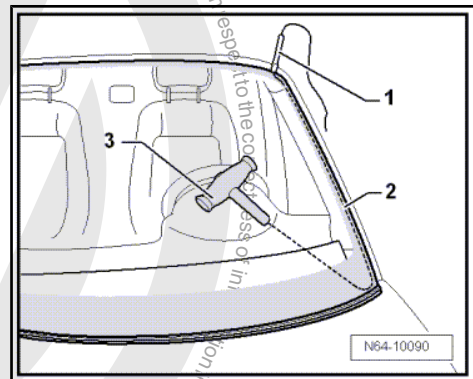

- Secure other end of cord to reel device -V.A.G 1654 A- .
- Position reel device -V.A.G 1654 A- in "position I".
- Reposition reel device -V.A.G 1654 A- as necessary and cut window free.
- Use wedge -V.A.G 1474/5- to press cutting cord against window glass while cutting in order to avoid damaging dash panel and to create clearance at window flange.

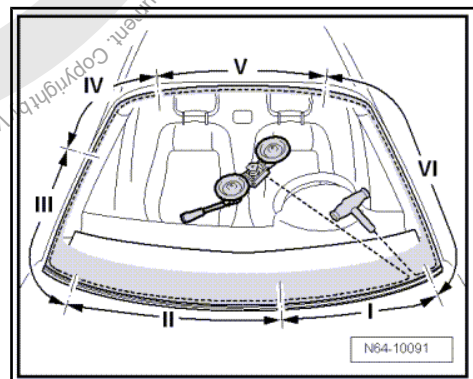

1.7 Installing windscreen

Preparing old undamaged window for glazing => [page 188](#)

Preparing new window for glazing => [page 188](#)

Preparing body flange for glazing => [page 190](#)

Installation instructions => [page 191](#)



Minimum curing period ⇒ [page 191](#)

1.8 Assembly overview - rear window

1 - Rear window

- Removing ⇒ [page 183](#)
- Installing ⇒ [page 185](#)

2 - Seal

- For rear window wiper

3 - Rear lid

4 - PUR adhesive sealant

- Cross section of bead: width = 6.5 mm, height = 10 mm (including residual material on window glass and window flange)
- Minimum curing period ⇒ [page 191](#)

5 - Trim

- Remove trim ⇒ General body repairs, interior; Rep. Gr. 70 ; Trim, insulation; Rear lid trim/insulation

6 - Window aerial contact

- Right and left

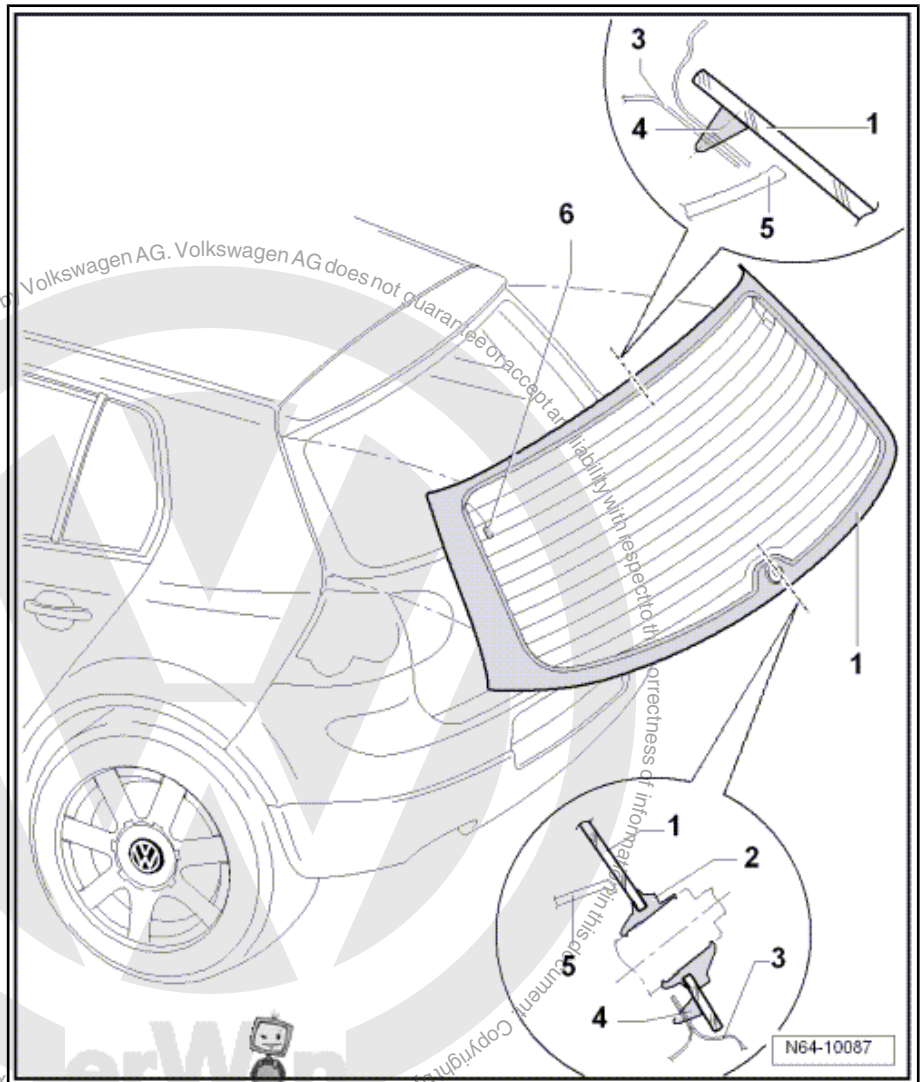

1.9 Removing undamaged rear window

- Remove rear lid trim ⇒ General body repairs, interior; Rep. Gr. 70 ; Trims, insulation; Luggage/load compartment trims .
- Remove rear window wiper motor ⇒ Electrical system; Rep. Gr. 92 ; Repairing rear window wipe and wash system .



- Pull off connections -1- on left and right for heated rear window and window aerial.

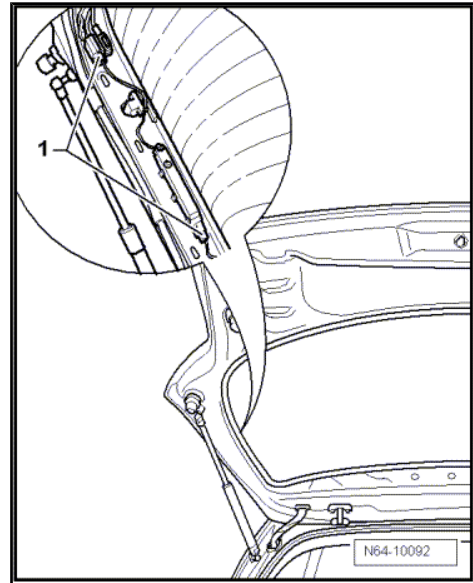

- Thrust awl -V.A.G 1474/2- -1- through adhesive bead.
- Pull cutting cord -2- through adhesive sealing material to inside using awl -V.A.G 1474/2- -1-.

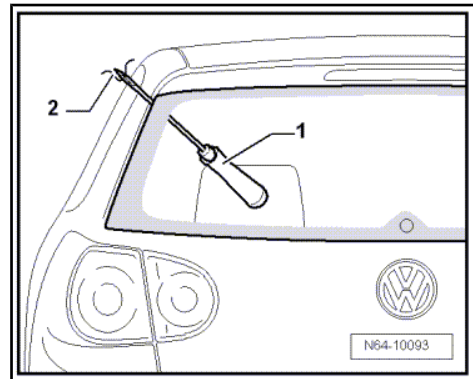

- Secure end of cutting cord -3- against falling out using pull handle -1-.
- Lay cutting cord -3- around window and guide second end of cord inwards into interior.
- Secure end of cord to reel device -V.A.G 1654- -2-.
- Position reel device -V.A.G 1654- -2- in "position I".
- Reposition reel device -V.A.G 1654- -2- as necessary and cut window free.
- Use wedge -V.A.G 1474/5- to press cutting cord -3- against window glass while cutting in order to have clearance at window flange.

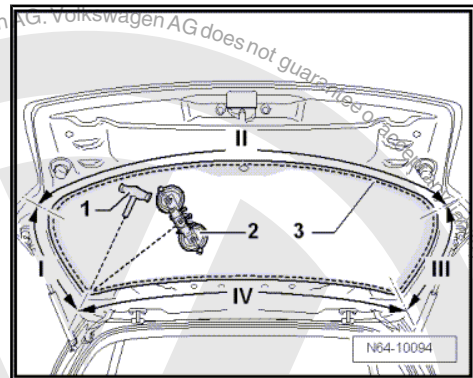

1.10 Removing broken rear window

- Protect body and interior against damage from glass splinters.
- Remove pieces of glass up to adhesive sealing material.
- Pull off connectors for rear window heating and aerial.



- Apply textile reinforced adhesive tape all around flange -1-.
- Cut through adhesive sealing material (with pieces of glass) in window aperture using electric cutter -V.A.G 1561 A- -3- and cutting blade -V.A.G 1561/10 - -2-

**WARNING**

Always wear protective goggles and leather gloves.

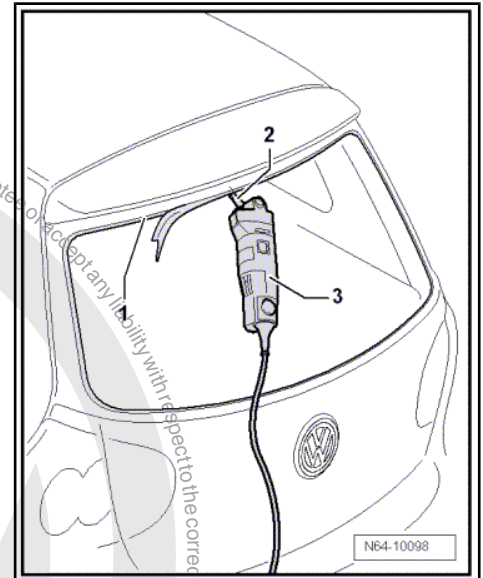

1.11 Installing rear window

Preparing old undamaged window for glazing ⇒ [page 188](#)

Preparing new window for glazing ⇒ [page 189](#)

Preparing body flange for glazing ⇒ [page 190](#)

Installation instructions ⇒ [page 191](#)

Minimum curing period ⇒ [page 191](#)





1.12 Assembly overview - rear side window

1 - Side window

- Removing side window
⇒ [page 186](#)
- Installing side window
⇒ [page 187](#)

2 - PUR adhesive sealant

- Cross section of bead:
width = 6.5 mm, height =
10 mm (including resid-
ual material on window
glass and window
flange)
- Minimum curing period
⇒ [page 191](#)

3 - Window flange

4 - Seal with spacing lip

- Integral part of side win-
dow

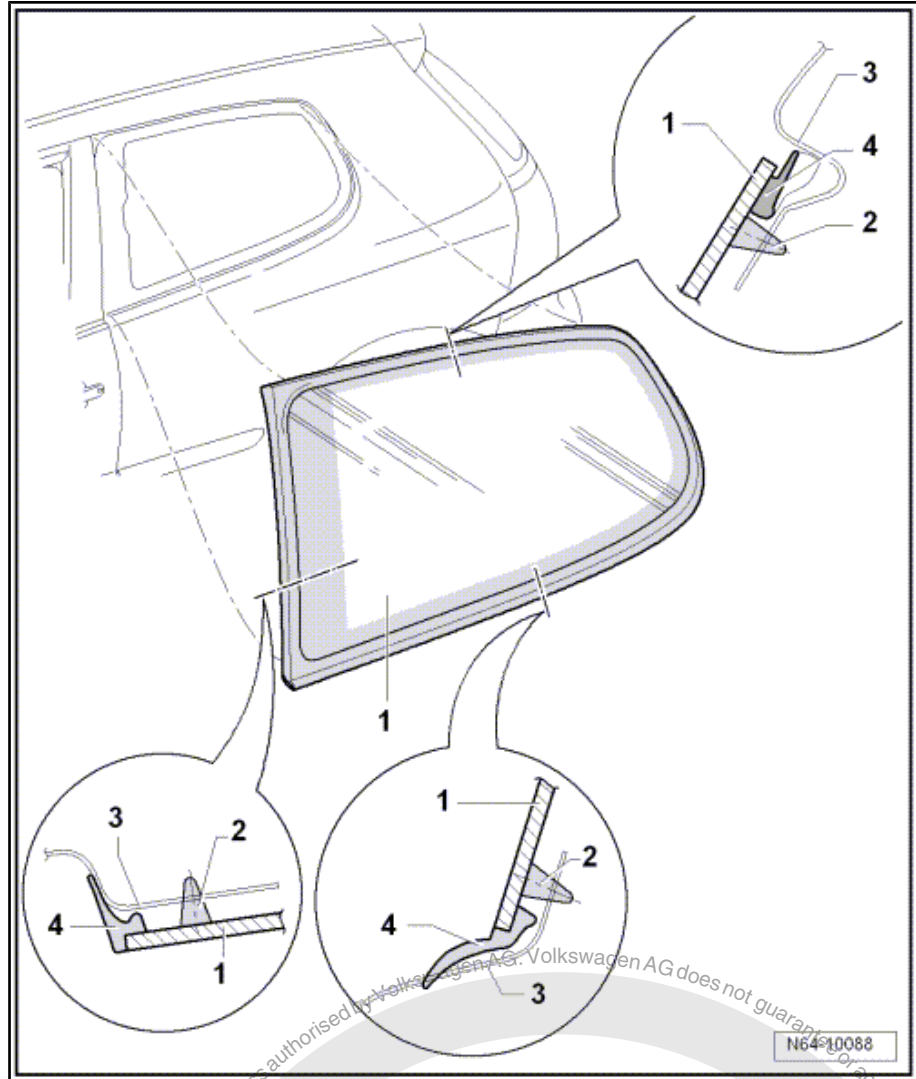

1.13 Removing undamaged rear side window

- Loosen interior trim in upper area ⇒ General body repairs, interior; Rep. Gr. 70 ; Trims, insulation; Load and luggage compartment trim .
- Remove B- and C-pillar trim ⇒ General body repairs, interior; Rep. Gr. 70 ; Trims, insulation; Pillar and side trims .
- Thrust awl -V.A.G 1474/2- -1- through adhesive bead.
- Pull cutting cord -2- through adhesive sealing material into inside of vehicle using awl -V.A.G 1474/2- -1-.

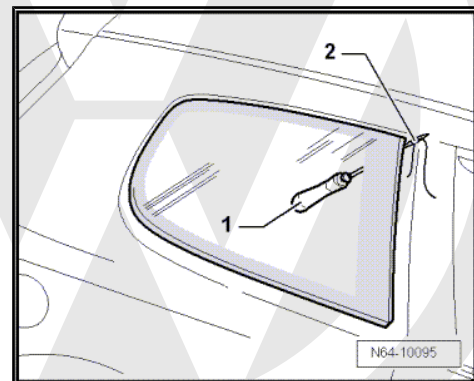



- Secure inside end of cutting cord against falling out using pull handle -V.A.G 1351/1- -1-.
- Separate sealing lip from window flange all around and spray in cleaning solution D 009 401 04 (as substitute for lubricant).
- Place cutting cord -2- around side window.
- Using small tube -3- feed cutting cord -2- between lip and window flange feed also second cord end into interior.

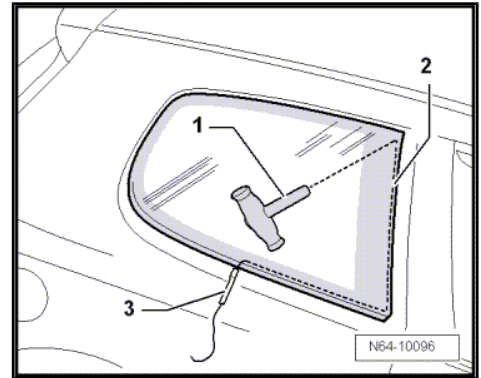

- Secure other end of cord to reel device -V.A.G 1654 A- and cut window free, repositioning reel device as necessary.
- Use wedge -V.A.G 1474/5- to press cutting cord against window glass while cutting in order to obtain clearance at window flange.

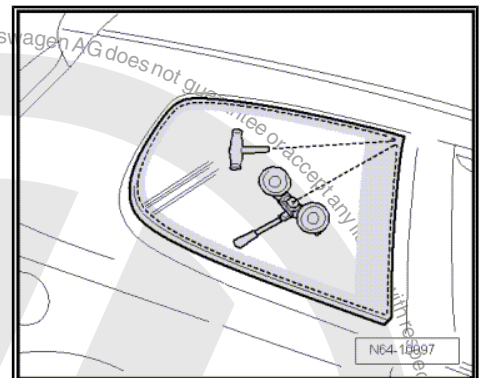

1.14 Removing damaged rear side window

A damaged side window is removed in much the same way as a damaged rear window.

1.15 Installing rear side window

Preparing old undamaged window for glazing ⇒ [page 188](#)

Preparing new window for glazing ⇒ [page 188](#)

Preparing body flange for glazing ⇒ [page 190](#)

Installation instructions ⇒ [page 191](#)

Minimum curing period ⇒ [page 191](#)



1.16 Preparing old undamaged window for glazing



Note

- ◆ If installing an undamaged window, cut back residual adhesive seal to 1...2 mm, being careful not to damage primer and ceramic coating.
- ◆ Remaining material serves as adhesion base for newly applied adhesive sealing compound.



WARNING

Do not prime adhesion surface and do not treat with a cleaning solution. Keep adhesion surface free of dirt and grease.

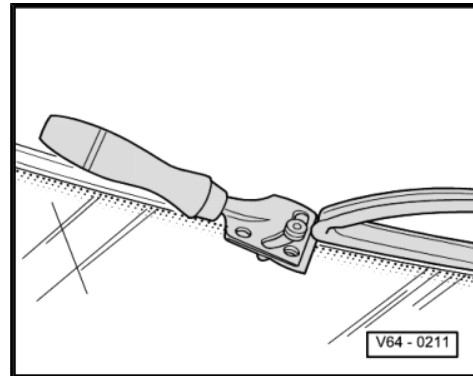

Exception: if bonding is not performed immediately after cutting back, the remaining residual material must be activated with activator D 181 801 A1.

1.17 Preparing new window without pre-coating for glazing

Only the applied ceramic layer and injection moulded sealing lip with spacer rib are found on all new windows.

Exception: rear window does not have a sealing lip or spacing lip.

- 1 - Sealing lip
- 2 - Spacing lip
- 3 - Window glass



Note

The area on which the adhesive bead is applied is not pre-coated or primed.

- Clean a 20 mm wide strip all around edge of window using cleaning solution D 009 401 04.
- Then rub edge of window dry using a lint free cloth.

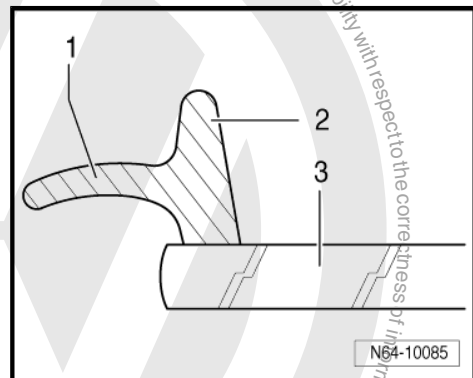

WARNING

Ceramic coating on window is not primer! It must be primed before application of adhesive sealing compound! Use only primer D 009 200 02!



- Apply primer -4- evenly in one motion using applicator D 009 500 25 -3- to the previously cleaned area -1- of window.

Ensure that glass adhesive is applied to primed area at a distance of approx. 2 mm from sealing lip -2-.

- Drying time approx. 10 minutes

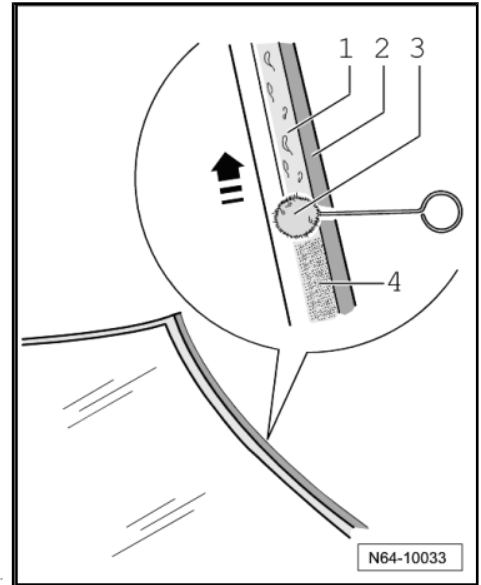

1.18 Preparing new window with precoating for glazing

A replacement part rear window is precoated. A PUR application area for the adhesive bead is sprayed onto this window.

- Rub over the precoating with a dry lint-free cloth.



WARNING

Do not prime precoating and do not treat with cleaning agent.

- Apply activator -2- evenly in one stroke using applicator D 009 500 25 -1-.
- Allow activator to flash off for at least 10 minutes.



Note

Activator must not come in contact with paint, or the paintwork will be damaged.

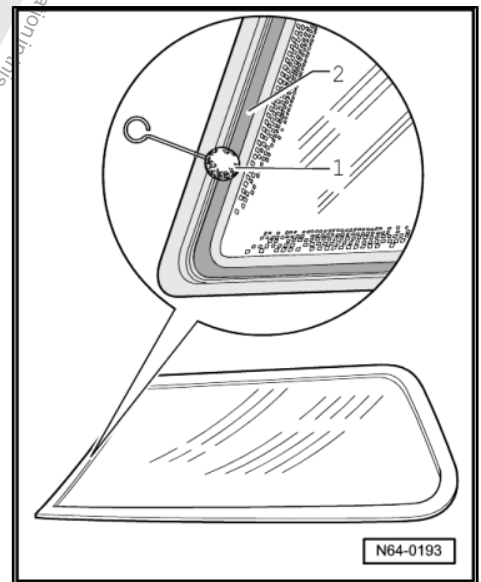



1.19 Preparing body flange for glazing

- Cut back remaining material on body flange with electric cutter -V.A.G 1561 A- and scraping blade -V.A.G 1561/8- , but do not remove completely.



Note

Remaining material serves as adhesion base for newly applied adhesive sealing compound. Keep dirt and grease off of bonding surfaces.



WARNING

Activator must not have contact with paint or the paintwork will be damaged.

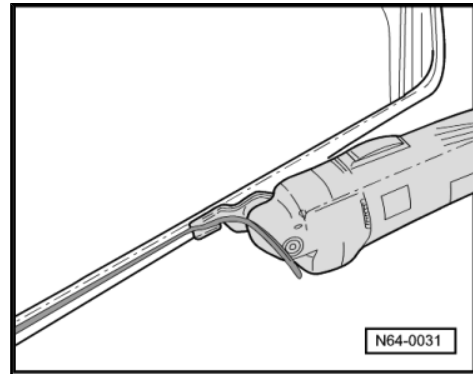

Exception: if bonding is not performed immediately after cutting back, the remaining residual material must be activated with activator D 181 801 A1.

- If the window flange has been repaired or partially renewed, after painting, the area concerned must be cleaned and primed again.



Note

It is possible that there is no laser weld seam in the area of the adhesive bead. In this case the open weld seam must be sealed with window adhesive before bonding the window.

- If the laser weld seam -3- on the panel flange -4- is not covered by the adhesive bead -1-, coat the laser weld seam -3- with glass/paint primer D 009 200 02 -3- and fill the laser weld seam with window adhesive DH 009 100 03 -1-.

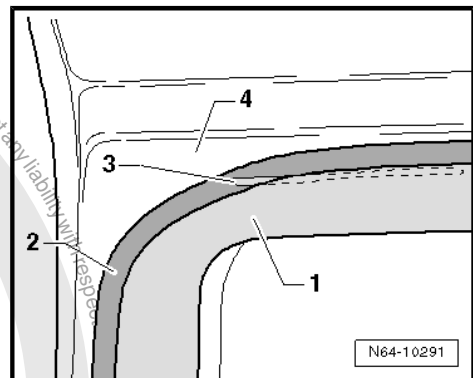



1.20 Installation instructions

- Apply adhesive material to primed area -1- or to trimmed sealant bead, holding double cartridge gun -VAS 5237- at right angle to window.



WARNING

Window must be installed within 10 minutes, or adhesive properties of window adhesive will be impaired.

- ◆ With help of two double suction cups (V.A.G 1344) install glass pane in window aperture, centre and press in to spacing lip.
- ◆ Secure windscreen during curing time with window adjusters (443 845 631 A).
- ◆ It is absolutely necessary to install the plenum chamber cover as described on page ⇒ [page 181](#) .
- ◆ Replace stickers (e.g. for airbag) which may be installed.
- ◆ Insert seal for rear window wiper motor drive shaft into rear window.
- ◆ The activator must not come into contact with the window heater bus bar.
- ◆ Marks have been made to the left and right on the rear window to aid in applying adhesive material.
- ◆ The sides of the rear window must not project above the contour of the rear lid under any circumstances!
- ◆ Use adhesive tape to secure rear window in position while curing.
- ◆ If the adhesive bead is too thick and the adhesive expands onto the area of the window heating, excess adhesive must be removed.

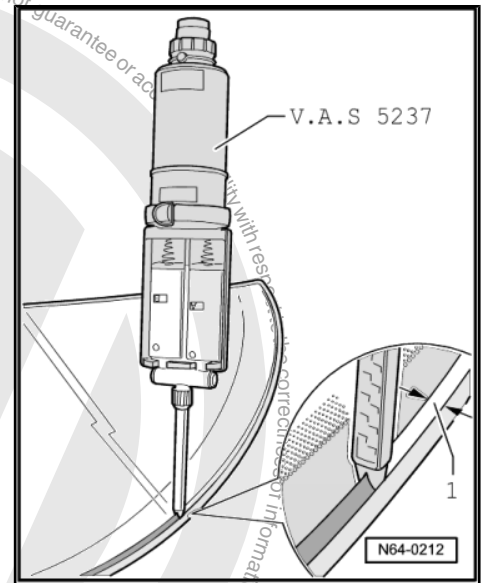

1.21 Minimum curing period



WARNING

Special standards must be adhered to when replacing bonded windows. One of these standards is, for example, that a freshly bonded windscreen must comply with the safety requirements, even in an accident, following the minimum prescribed curing period.

The minimum curing time for the 2-component adhesive DA 004 600 A2 is three hours for all windows.

Minimum curing period is the time from bonding the window until the vehicle may be used. During this time, the vehicle must stand on a level surface at room temperature (at least 15 °C).



WARNING

Vehicle is safe to use only after the minimum curing period is completed.



1.22 Touching up paint damage

If paintwork is damaged, paint structure must be restored according to specifications in the "Paint" workshop manual.

1.23 Cleaning off excess adhesive sealing material

- It is recommended to use cleaning solution D 002 000 10 as a cleaner. Observe the appropriate safety precautions when performing this work.



WARNING

Glass which has just been installed should not be pressed outwards whilst cleaning from inside of vehicle.

- First clean painted surface as much as possible using a dry cloth. Remove remaining adhesive with adhesive remover D 002 000 10.
- Cleaning plastic trim: allow adhesive sealant to cure (approx. one hour) and then peel off.

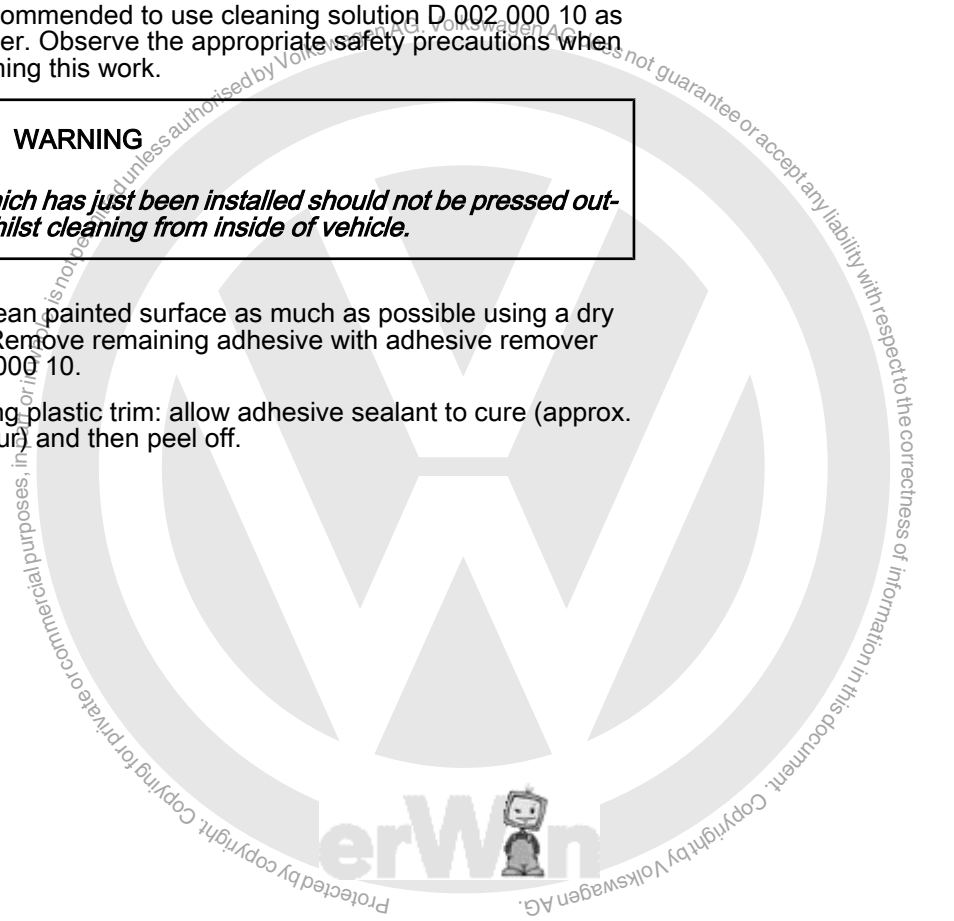



2 Front door windows

2.1 Tools

Special tools and workshop equipment required

- ◆ Torque wrench 2...10 Nm -V.A.G 1783-

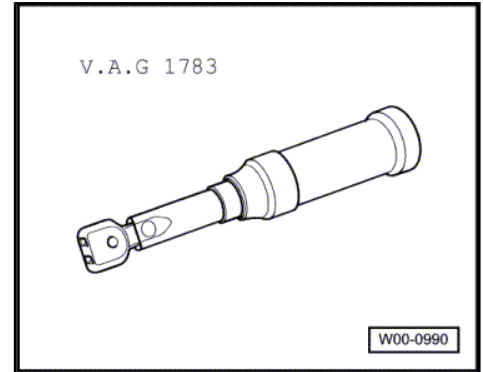



2.2 Assembly overview - front door window



Note

- ◆ The right side is shown. The left side is similar.
- ◆ The bolt -4- is accessible from interior and exterior. From exterior the bolt has a right-hand thread. This means: from exterior the bolt is removed by turning it to left, from interior the bolt is removed by turning it to right.

1 - Door window

- Removing and installing
⇒ [page 195](#)

2 - Window guide

- Removing and installing
⇒ [page 201](#)

3 - Mounting

4 - Bolt

- Accessible from exterior (right-hand thread), remove by turning anti-clockwise, remove door outer panel ⇒ [page 94](#)
- Accessible from interior, remove by turning it to right, removing front door trim ⇒ General body repairs, interior; Rep. Gr. 70 ; Trims, insulation; Door trims

- Qty. 2

- 8 Nm

5 - Window regulator

- Removing and installing
⇒ [page 203](#)

6 - Cover

- Qty. 2

7 - Window regulator motor

- Removing and installing
⇒ [page 199](#)

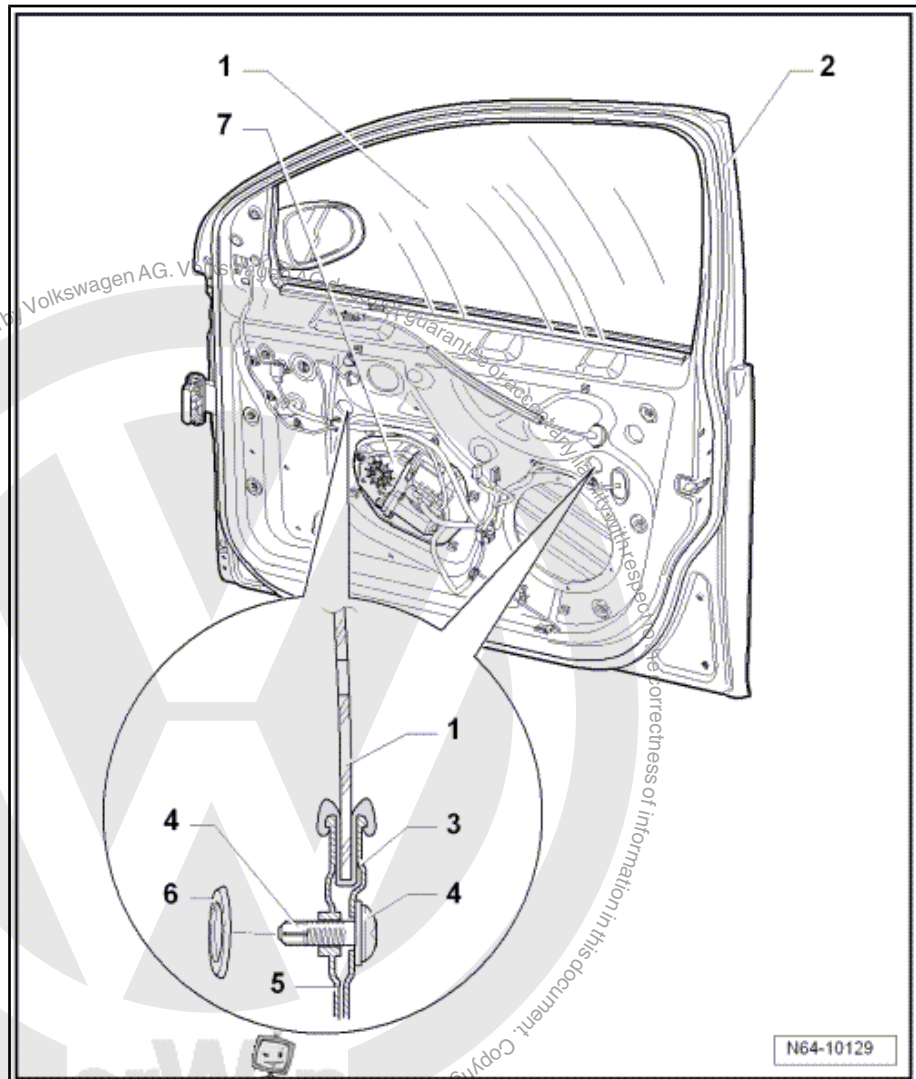

N64-10129



2.3 Removing and installing door window

Note

- ◆ *The removal and installation sequence is only for the right door window. The removal and installation of the left door window is similar.*
- ◆ *The bolt -4- is accessible from interior and exterior. From exterior the bolt has a right-hand thread. This means: from exterior the bolt is removed by turning it to left, from interior the bolt is removed by turning it to right.*

2.3.1 Removing

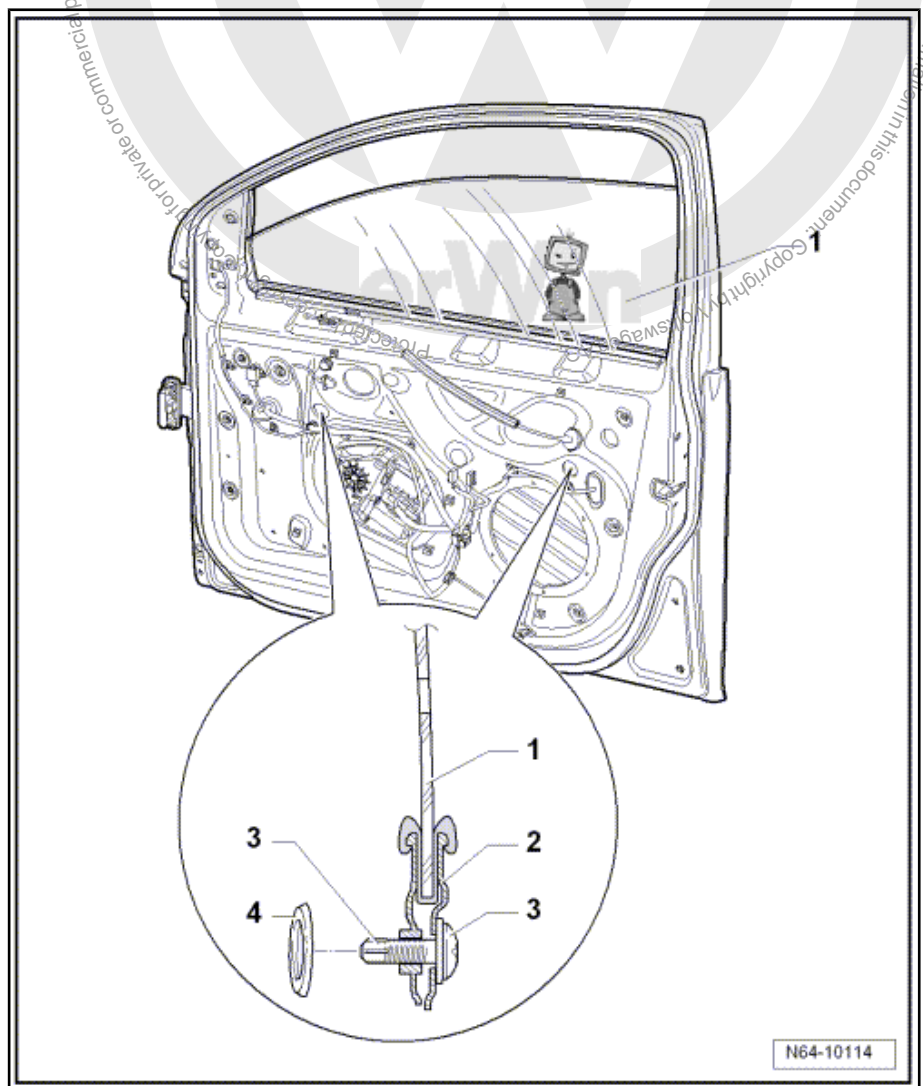

- Remove front door trim ⇒ General body repairs, interior; Rep. Gr. 70 ; Trim, insulation; Door trims .
- Lever out caps -4-.
- Lower door window -1- until clamping bolts -3- for mounting -2- are accessible.



WARNING

Remove bolt -3- from interior by turning to right.

- Loosen bolts -3- (do not remove) from inside by turning to right and press clamping jaws apart.



Note

If the work step cannot be carried out because there is a fault with the electric window motor, remove motor to slide window down.

- Lift rear of door window -1- and swivel out of door forwards, in -direction of arrow-.

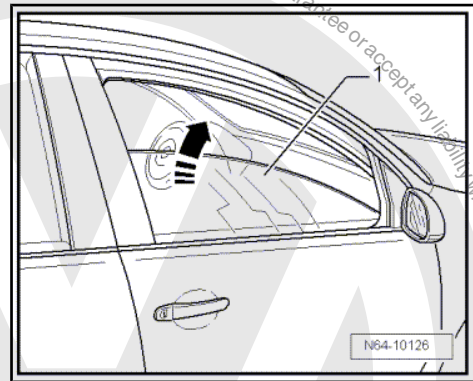

2.3.2 Installing

- Insert door window -1- in door in -direction of arrow-.
- Ensure that door window -1- is properly located in window guides.
- The bolt can now be tightened by turning to left.

Further installation is performed in the reverse order of removal.

- Then check for correct operation.

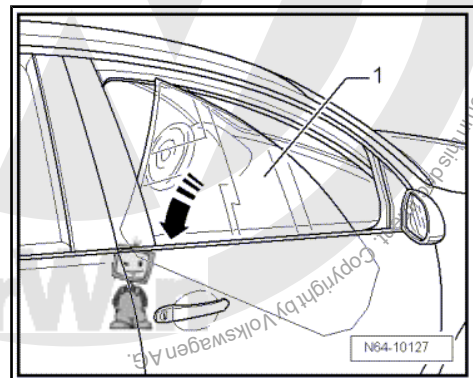



2.4 Adjusting door window

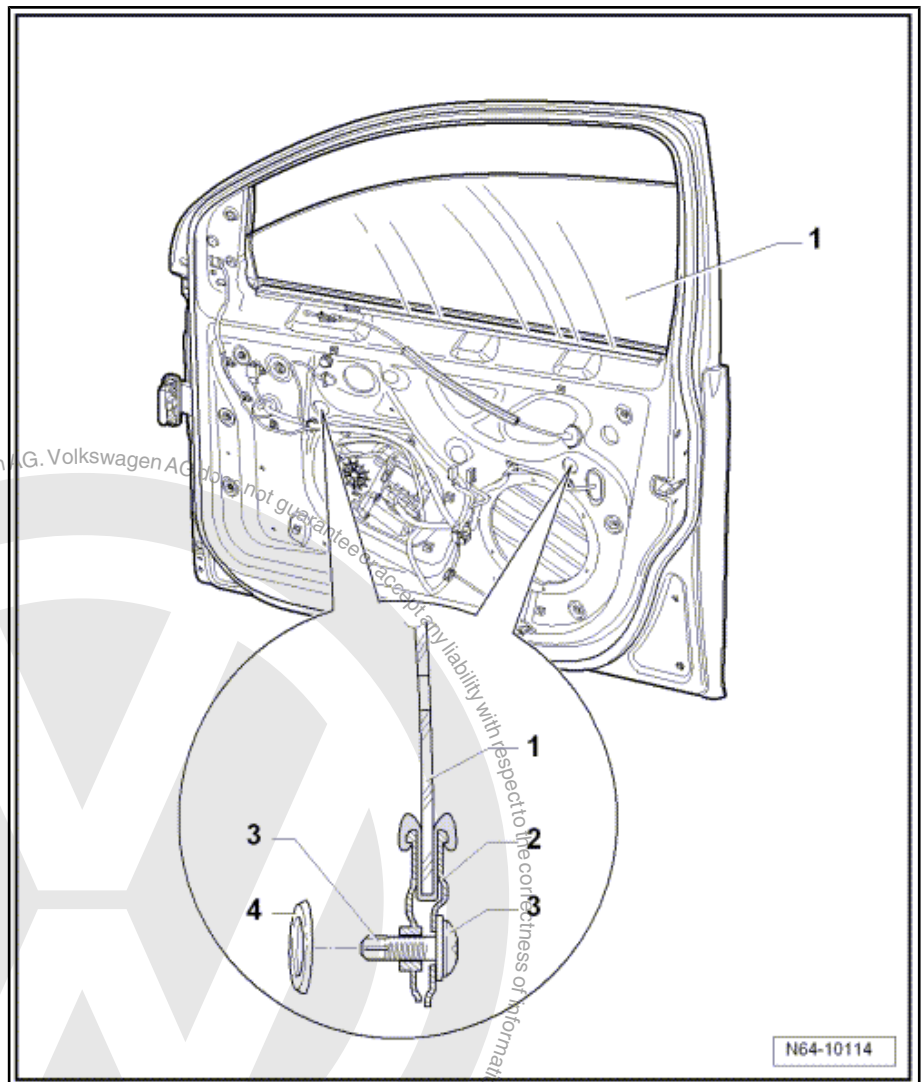

- Remove front door trim ⇒ General body repairs, interior; Rep. Gr. 70 : Trim, insulation; Door trims .
- Lever out caps -4-.
- Lower door window -1- until clamping bolts -3- for mounting -2- are accessible.



WARNING

Remove bolt -3- from interior by turning to right.

- Loosen bolts -3- (do not remove) from inside by turning to right and press clamping jaws apart.



- Applying light pressure press door window -1- in clamping jaws in -direction of arrow- and align door window tension free at rear window guide.
 - When doing so, ensure that door window -1- is positioned parallel to window guide.
 - Tighten clamping jaws by turning bolts -3- to left from interior.
- Specified torque for bolt: 8 Nm.
- Then check for correct operation.
- Further installation is performed in the reverse order of removal.

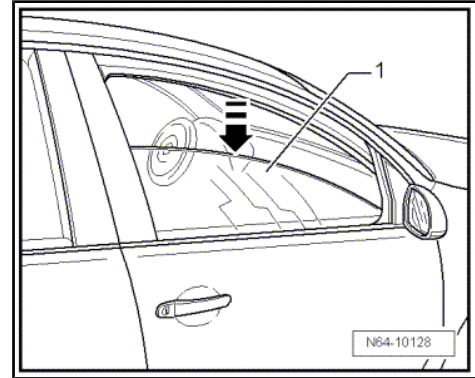

2.5 Assembly overview - window regulator motor



Note

The right side is shown. The left side is similar.

1 - Window regulator motor

- Removing and installing
⇒ [page 199](#)

2 - Bolt

- Qty. 3
- 3.5 Nm

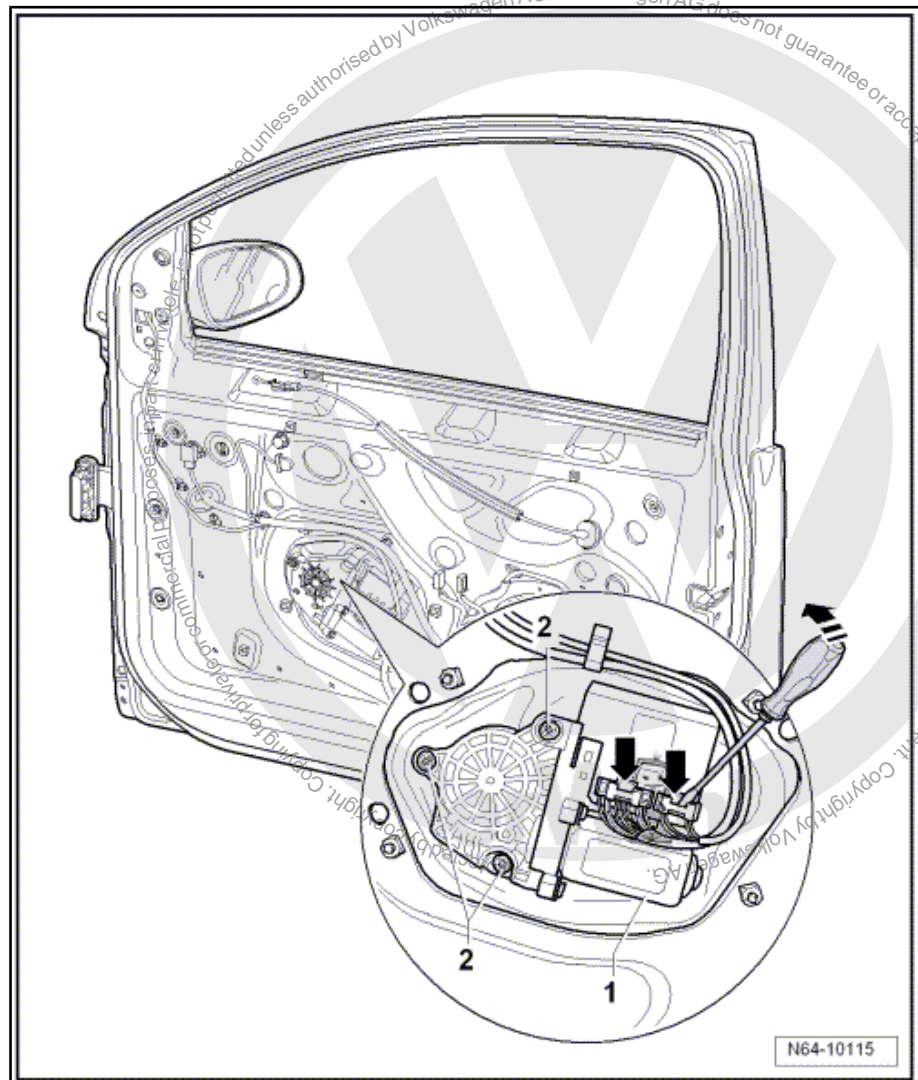



2.6 Removing and installing window regulator motor

Note

- ◆ *The removal and installation sequence is only for the right door window regulator. The removal and installation of the left door window regulator is similar.*
- ◆ *The window regulator motor can also be removed with mounting plate when door outer panel is removed.*

2.6.1 Removing

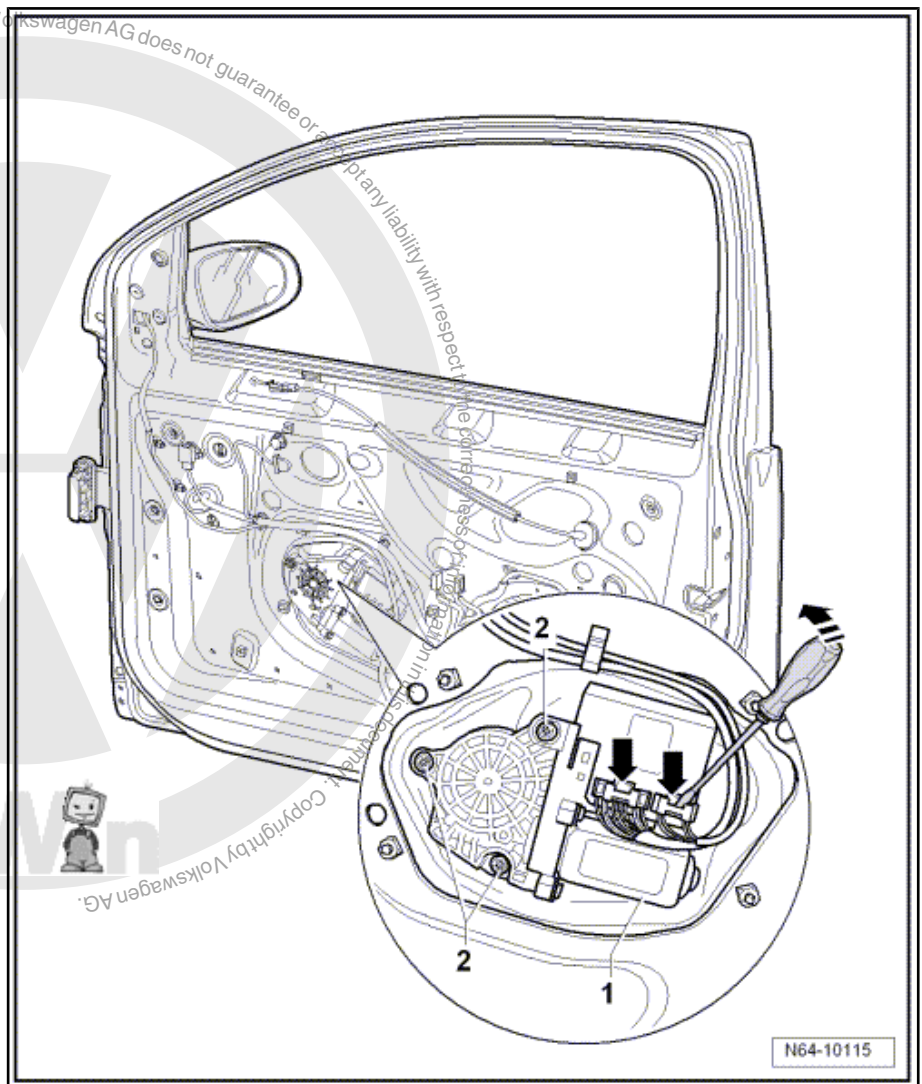

- Remove front door trim ⇒ General body repairs, interior; Rep. Gr. 70 ; Trim, insulation; Door trims .
- Secure door window against sliding down with adhesive tape.
- Release connectors -arrows- using a screwdriver in -direction of arrow-.
- Remove the three bolts -2-.



- Remove window regulator motor and control unit -1- from mounting plate.

2.6.2 Installing

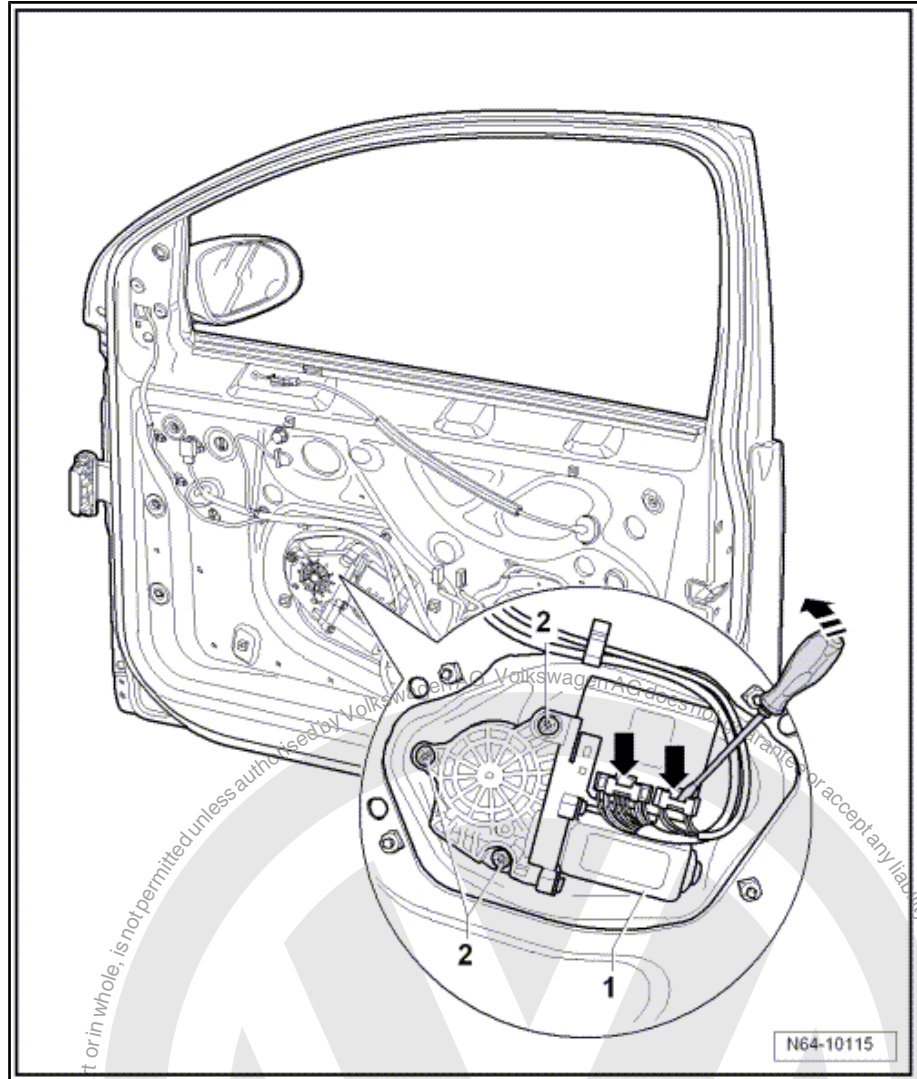

- Place window regulator motor -1- on and attach connectors -arrows-.
- Move door window lightly up and down so that the splines between motor and cable drum engage easier.
- Tighten window regulator motor bolts -2- specified torque (3.5 Nm).
- Run window twice to upper stop and then down to lower stop. This normalises and readies the window, it also activates the pinch/roll-back function.

Then perform remaining installation in reverse order of removal.



2.7 Assembly overview - window guide

Note

- ◆ *The right side is shown. The left side is similar.*
- ◆ *For a better representation the illustration is drawn without door outer panel.*

1 - Window guide

2 - Trim

3 - Bolt

- Qty. 2
- 2 Nm

4 - Window frame on door inner part

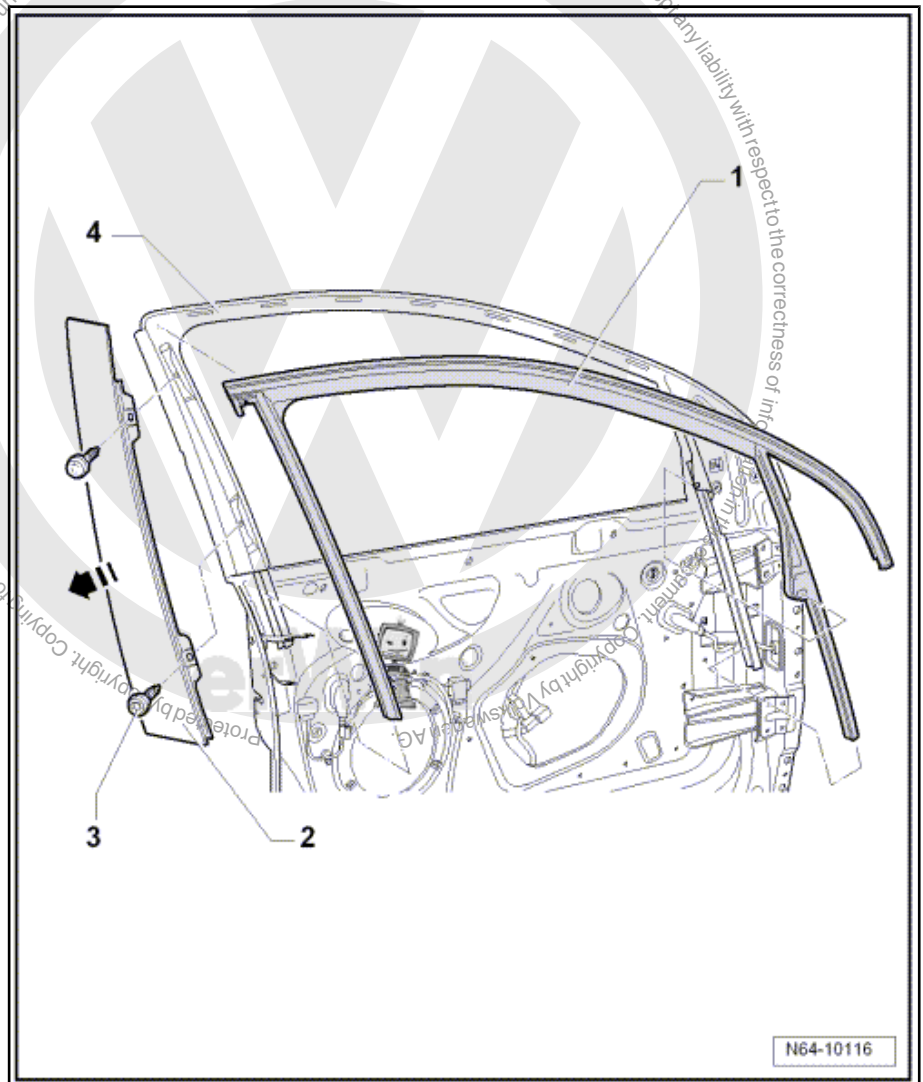

2.8 Removing and installing window guide

Note

- ◆ *The removal and installation sequence is only for the right window guide. The removal and installation of the left window guide is similar.*
- ◆ *For a better representation the removal and installation is drawn without door outer panel.*



2.8.1 Removing

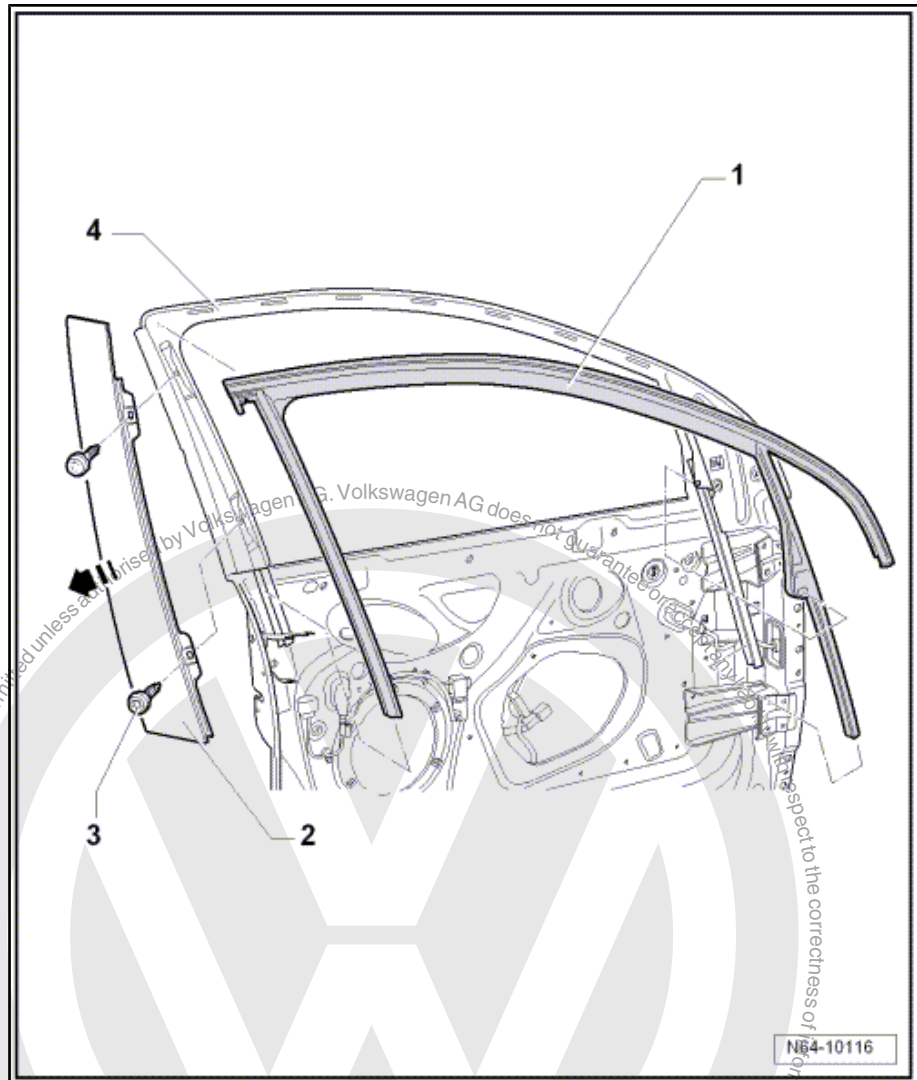

- Remove exterior mirror ⇒ [page 227](#) .
- Pull window guide -1- out of mounting.
- Remove bolts -3- (Qty. 2) and pull trim plate -2- off in direction of B-pillar -direction of arrow-.
- Pull window guide -1- off all around window frame -4- and remove upwards out of window slot.

2.8.2 Installing

Installation is carried out in reverse order of removal.



Note

Ensure window guide seats evenly when installing (wind noises).



2.9 Assembly overview - window regulator

i Note

The right side is shown. The left side is similar.

1 - Window regulator

- Removing and installing
 => [page 203](#)

2 - Bolt

- Qty. 4
- 8 Nm

3 - Bolt

- Qty. 5 on 4-door models
- Qty. 4 on 2-door models
- 8 Nm

4 - Drive

5 - Mounting plate

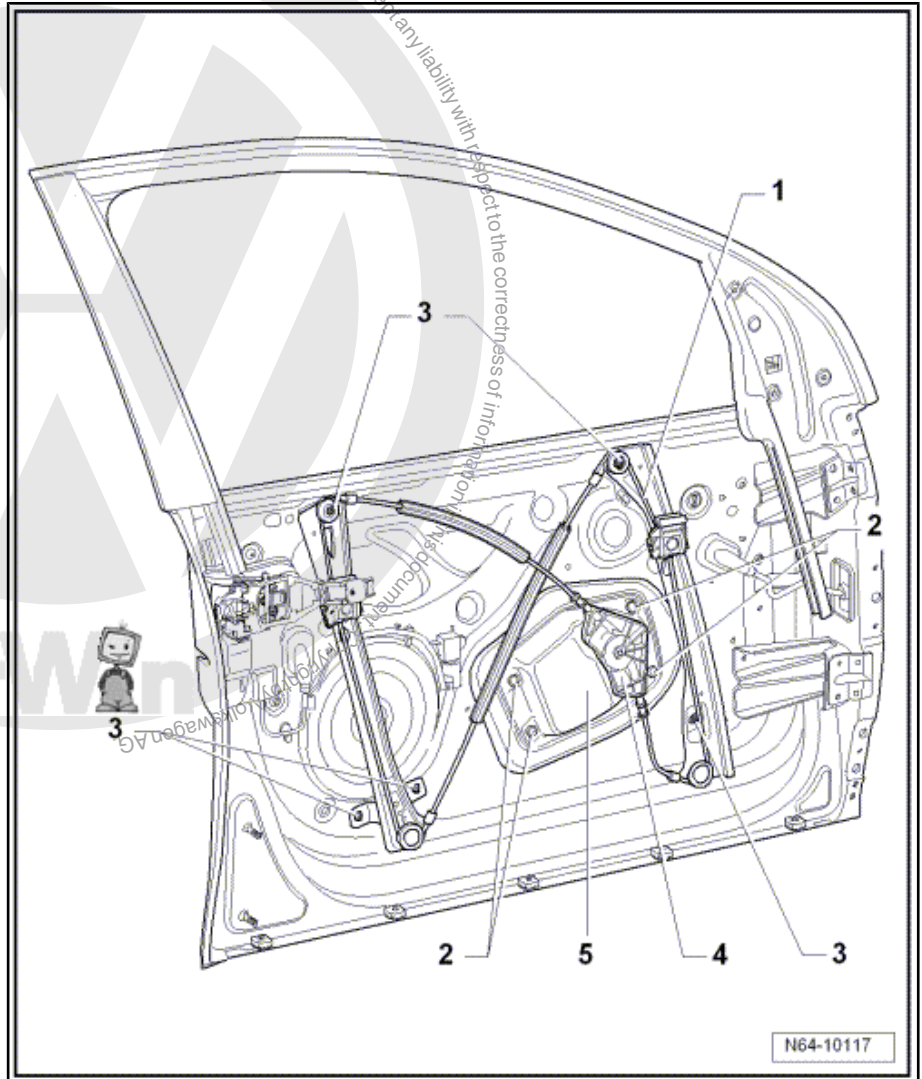

2.10 Removing and installing window regulator

i Note

- ◆ The removal and installation sequence is only for the right window regulator. Removal and installation of the left window regulator is similar.
- ◆ The removal and installation procedures may have to be modified slightly depending on 2 or 4-door models



2.10.1 Removing

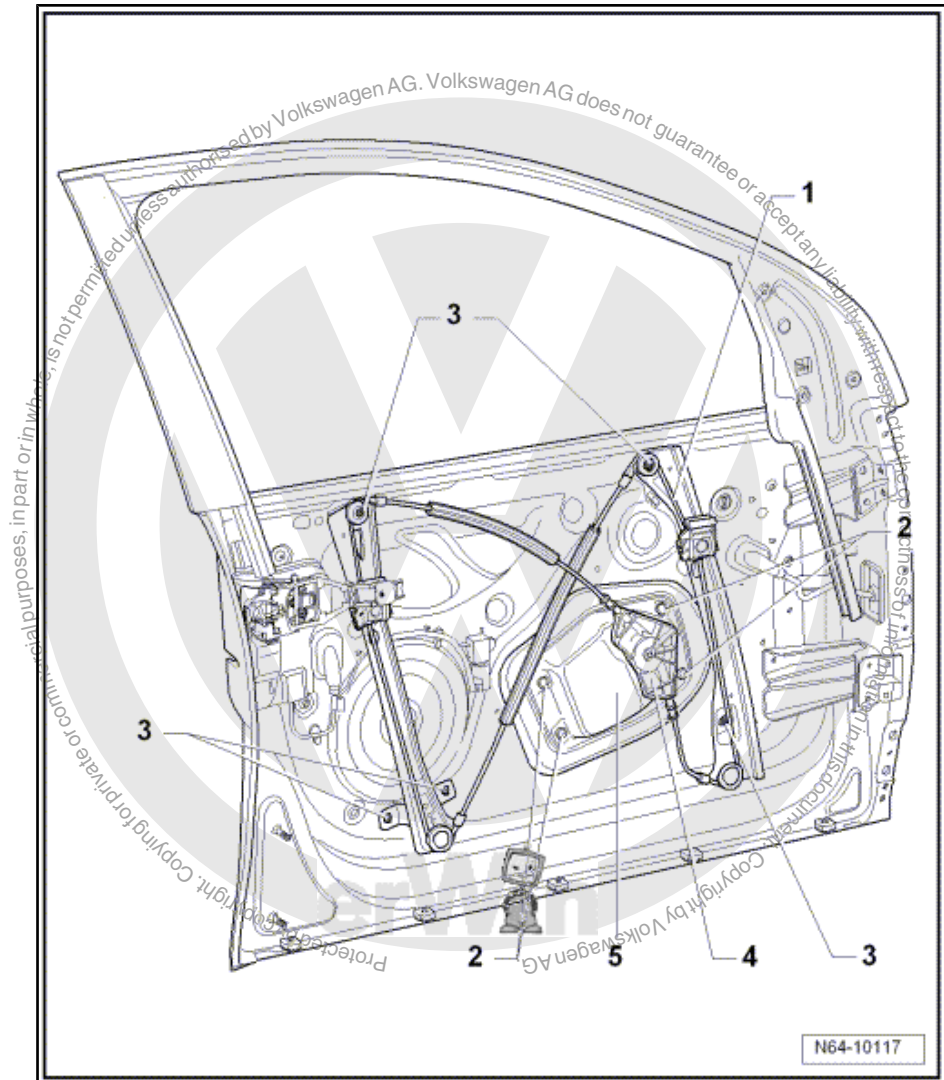

- Remove door outer panel ⇒ [page 94](#) .
- Remove side impact protection ⇒ [page 74](#)
- Remove door window ⇒ [page 195](#) .
- Remove bolts -2- from mounting plate -5-.
- Remove window regulator bolts -3-.
- Remove window regulator -1- with drive -4- and window regulator motor mounting plate -5- off door inner part.
- Disconnect window regulator motor connector ⇒ [page 199](#)

2.10.2 Installing

Installation is carried out in reverse order of removal.

- Carry out functional check before installing door outer panel.



3 Rear door windows

3.1 Tools

Special tools and workshop equipment required

- ◆ Release tool -T10236-

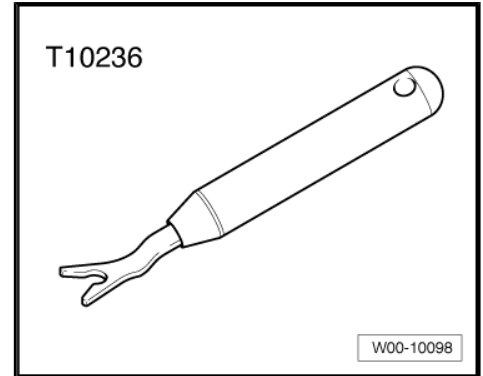

- ◆ Torque wrench 2...10 Nm -V.A.G 1783-

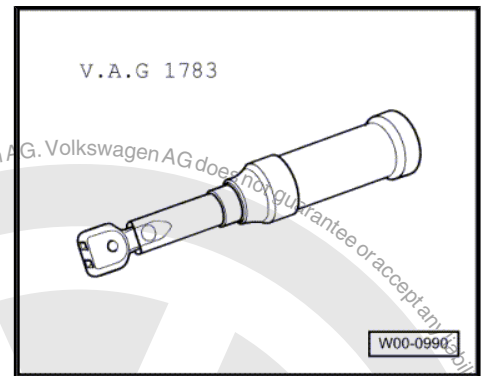

Protected by copyright. Copying for private or commercial purposes, in part or in whole, is not permitted unless authorised by Volkswagen AG. Volkswagen AG does not guarantee or accept any liability with respect to the correctness of information in this document. Copyright by Volkswagen AG.

erWin



3.2 Assembly overview - rear door window



Note

The right side is shown. The left side is similar.

1 - Door window

- Removing and installing
⇒ [page 206](#)

2 - Window guide

- Integral part of fixed door window
- Removing and installing
⇒ [page 209](#)

3 - Fixed door window

- Integral part of window guide
- Removing and installing
⇒ [page 209](#)

4 - Window regulator guide

5 - Spreader pin

- Always renew when working on door window

6 - Spreader plug

- Always renew when working on door window

7 - Cover

8 - Window regulator

- Removing and installing
⇒ [page 215](#)

9 - Window regulator motor

- Removing and installing
⇒ [page 212](#)

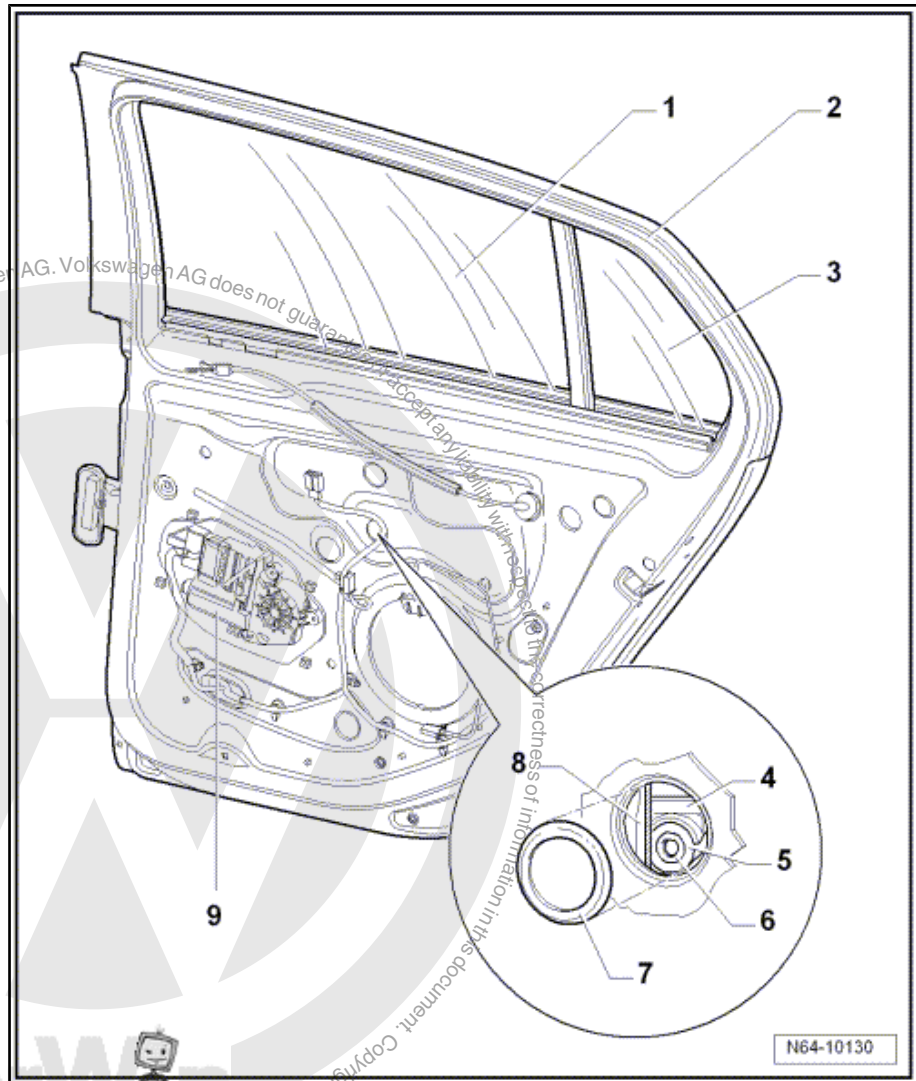

3.3 Removing and installing door window



Note

- ◆ *The removal and installation sequence is only for the rear right door window. The removal and installation of the rear left door window is similar.*
- ◆ *When door outer panel has been removed the spreader pin and spreader plug to remove door window are accessible from exterior.*



3.3.1 Removing

- Remove rear door trim => General body repairs, interior; Rep. Gr. 70 ; Trims, insulation; Door trims .
- Lever out caps -5-.
- Lower door window until spreader pin -3- and spreader plug -4- are accessible in aperture of window regulator.

i Note

If the work step cannot be carried out because there is a fault with the electric window motor, remove motor to slide window down.

- Screw a 5 mm bolt (approx. 70 mm long) into the spreader pin -3- and pull out from spreader plug -4-.
- Screw an 8 mm bolt (approx. 80 mm long) into spreader plug -4-.

i Note

Do not exert too great a pressure on the plug because otherwise the plug will fall into the door.

- Pull spreader plug -4- out of clamping jaws -1- and therefore out of door window.

Pull window guide -3- out of mounting.

Remove screws -2- and pull trim -1- towards B-pillar -direction of arrow-.

- Pull door window upwards -arrow- out of window slot.

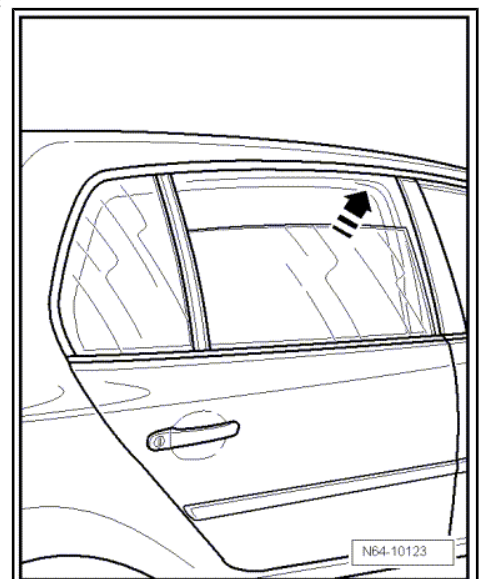
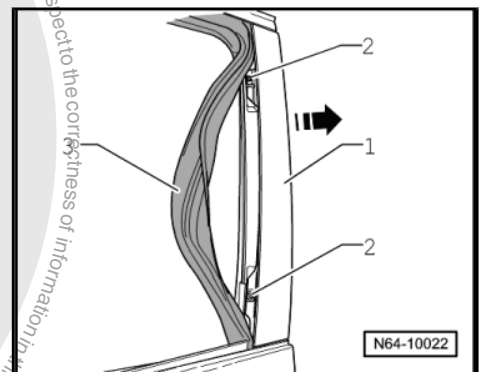
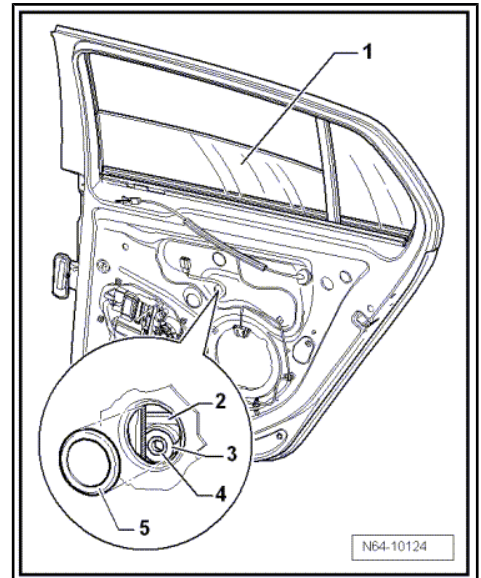



3.3.2 Installing



Note

- ◆ *When installing door window, always renew spreader plug and spreader pin.*
- ◆ *Before inserting spreader plug and spreader pin check washer for damage.*
- With door window -1- removed insert spreader plug -3- in middle - centralised.
- Press spreader pin -2- flush into spreader plug -3-.
- Guide door window -1- into door and place door window on window regulator guide mounting -4-.
- With light pressure from above -arrow-, engage window -1- in window regulator guide -4-.
- Then perform remaining installation in reverse order of removal.
- Carry out functional test function before installing door trim.

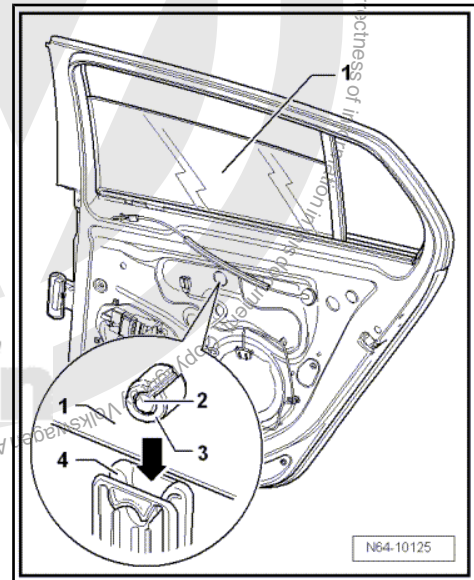



3.4 Assembly overview - fixed door window with window guide

1 - Window guide

- ❑ Component part of fixed door window
- ❑ Removing and installing
⇒ [page 209](#)

2 - Fixed door window

- ❑ Part of window guide
- ❑ Removing and installing
⇒ [page 209](#)

3 - Window frame on door inner part

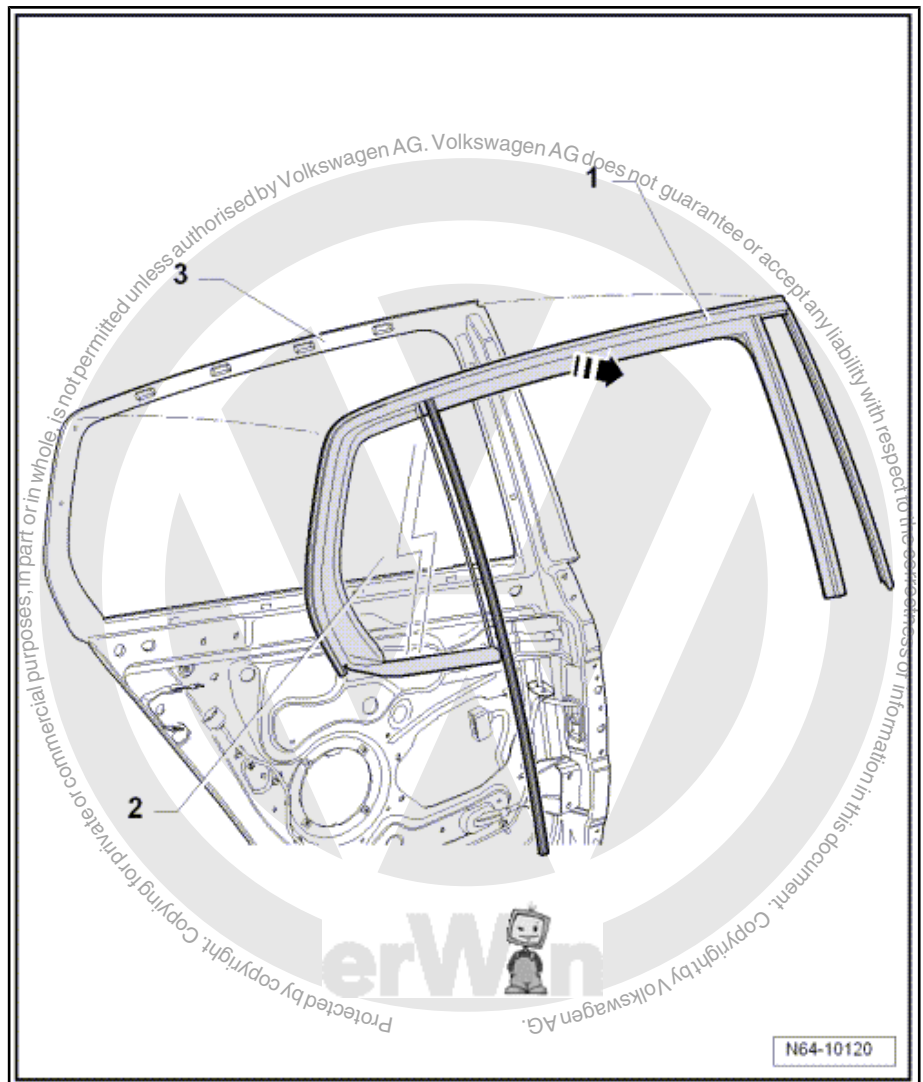

3.5 Removing and installing fixed door window with window guide



Note

- ◆ *The removal and installation sequence is only for the right fixed door window with window guide. The removal and installation of the left fixed door window with window guide is similar.*
- ◆ *When door outer panel has been removed the spreader pin and spreader plug to remove door window are accessible from exterior.*

3.5.1 Removing

- Remove door outer panel ⇒ [page 94](#) .
- Remove door window ⇒ [page 206](#) .



- Pull window guide -1- out of centre rib -3- and guide window guide inwards.
- Remove bolts -2- and slide centre rib -3- downwards -arrow a-.
- Pull centre rib -3- off fixed door window seal -arrow b-.

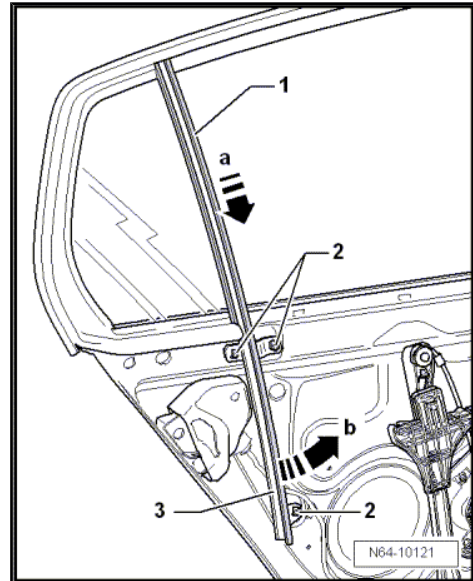

- Release window guide -1- with fixed door window -2- inside and outside of window frame -4-.
- Using release tool -T 10236- release locking lugs on guide pin -3- in window frame -4-.

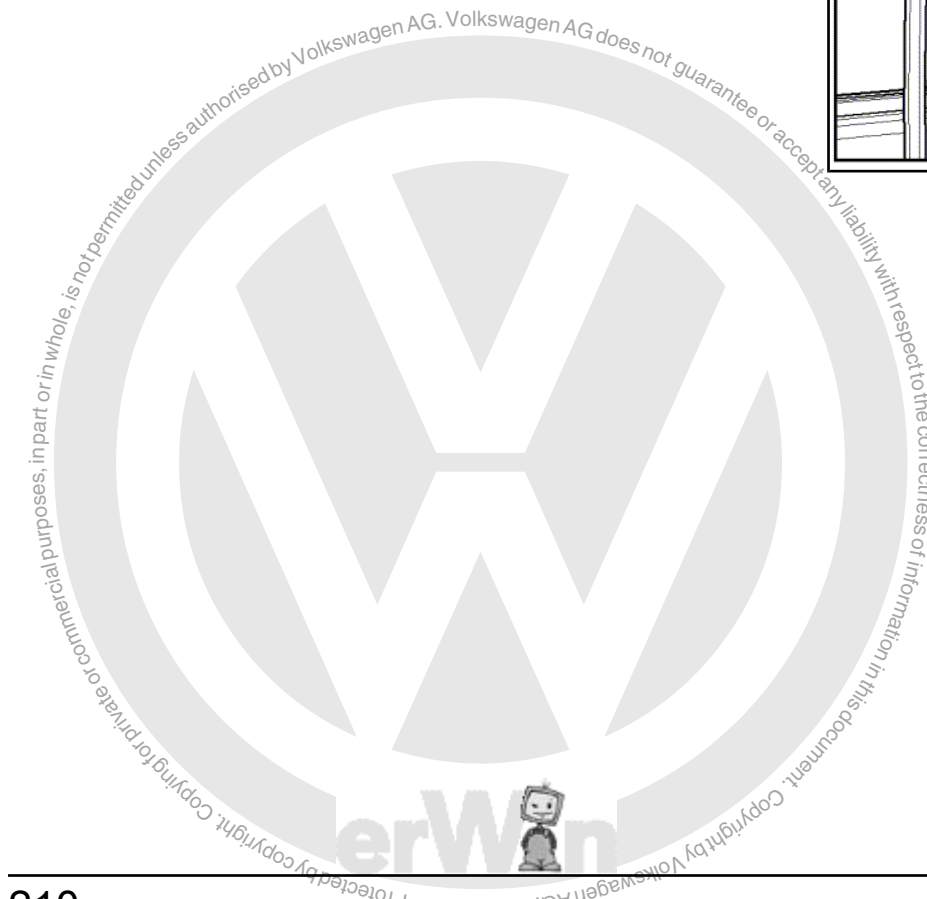
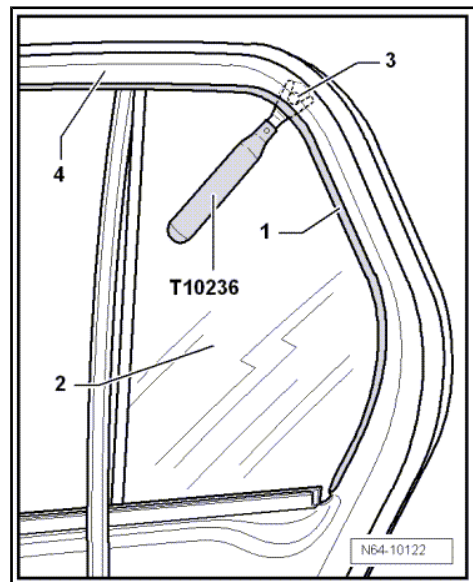

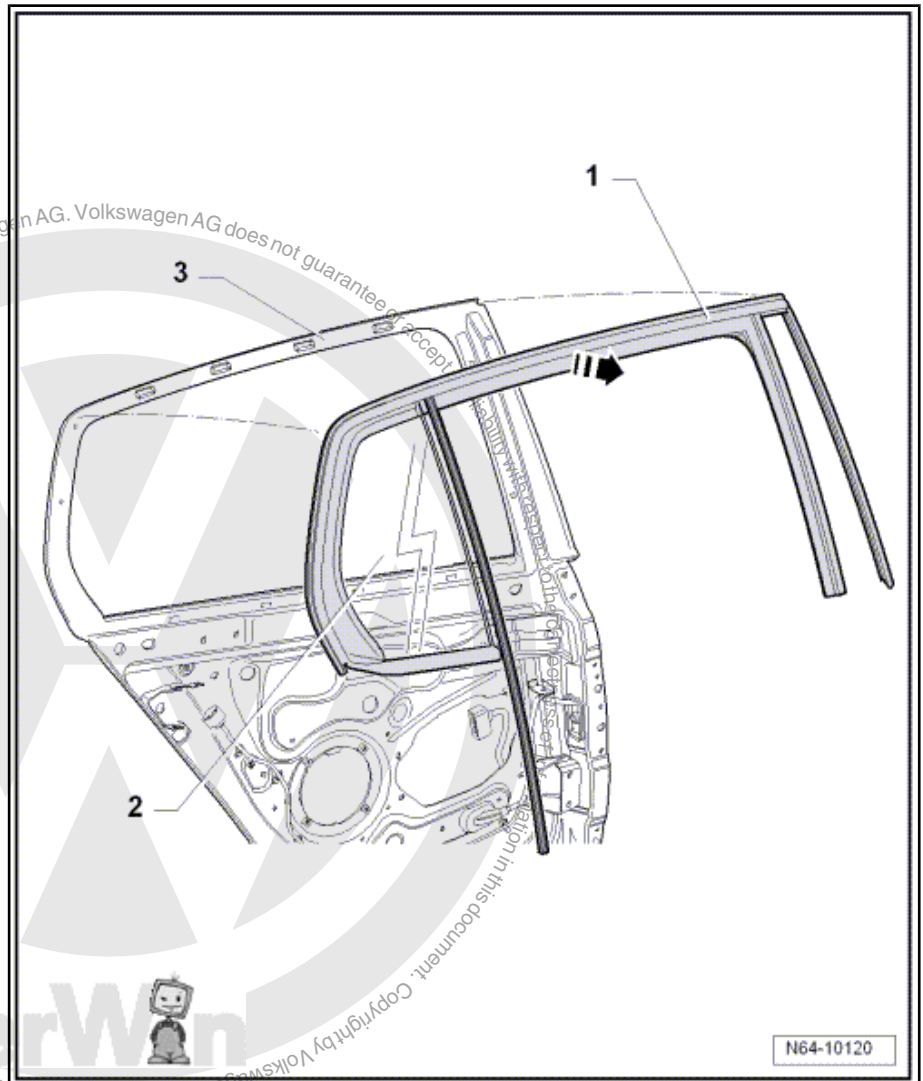

- Pull complete window guide -1- with fixed door window -2- off window frame -3- in -direction of arrow-.

3.5.2 Installing

Installation is carried out in reverse order of removal.

Specified torque for bolts on middle frame: 5.5 Nm

 **Note**

When installing fixed door window with window guide ensure it is seated uniformly (wind noise).



3.6 Assembly overview - window regulator motor



Note

The right side is shown. The left side is similar.

1 - Connector

2 - Bolt

- Qty. 3
- 3.5 Nm

3 - Window regulator motor

- Removing and installing
[⇒ page 212](#)

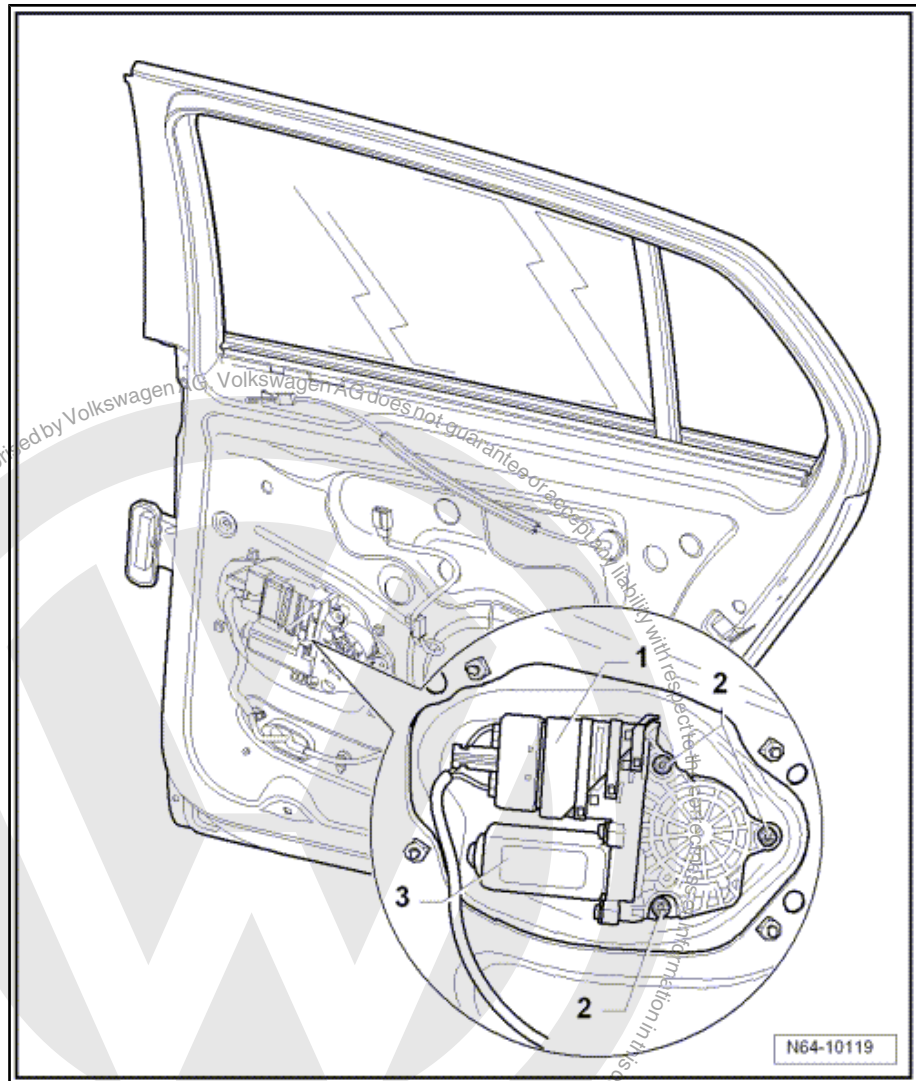

3.7 Removing and installing window regulator motor



Note

- ◆ The removal and installation sequence is only for the right door window regulator. The removal and installation of the left door window regulator is similar.
- ◆ The window regulator motor can also be removed with mounting plate when door outer panel is removed.



3.7.1 Removing

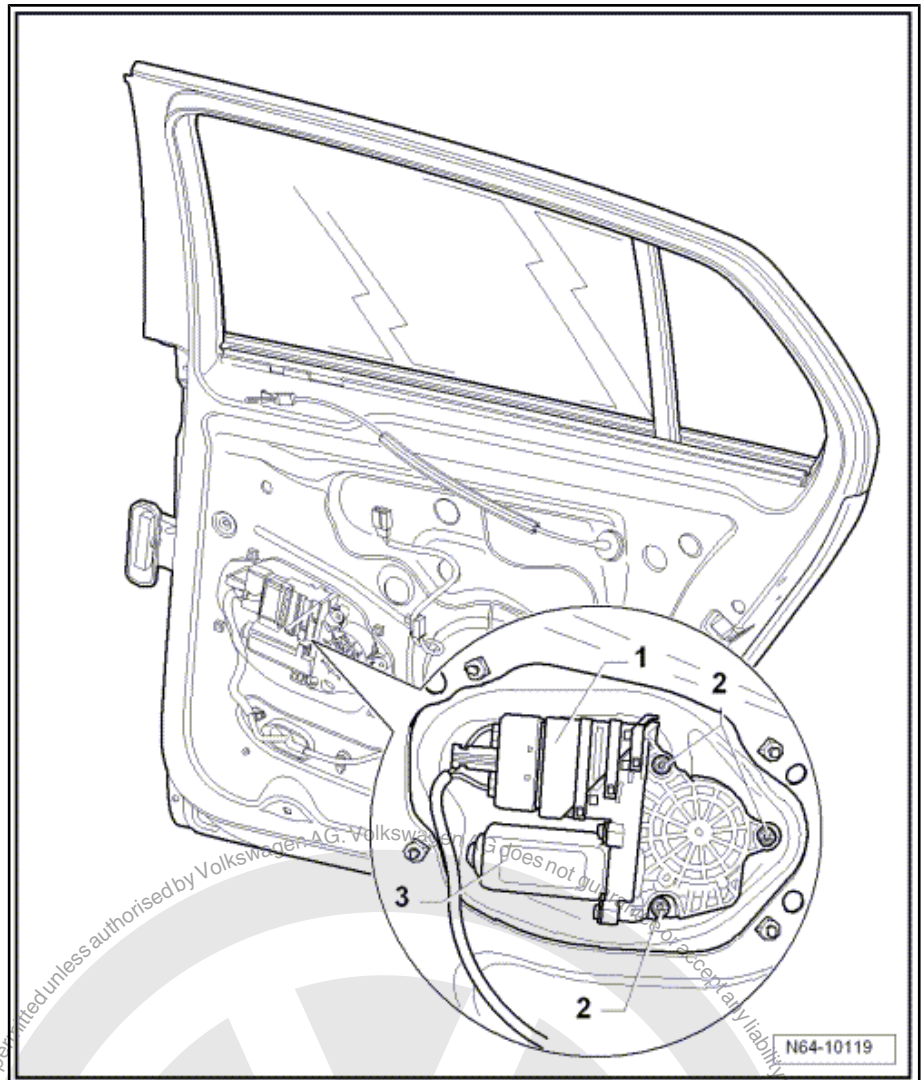

- Removing door trim ⇒ General body repairs, interior; Rep. Gr. 70 ; Trims, insulation; Door trims .
- Secure door window against sliding down with adhesive tape.
- Remove the three bolts -2-.
- Disconnect connector -1-.
- Remove window regulator motor and control unit -3- from mounting plate.



3.7.2 Installing

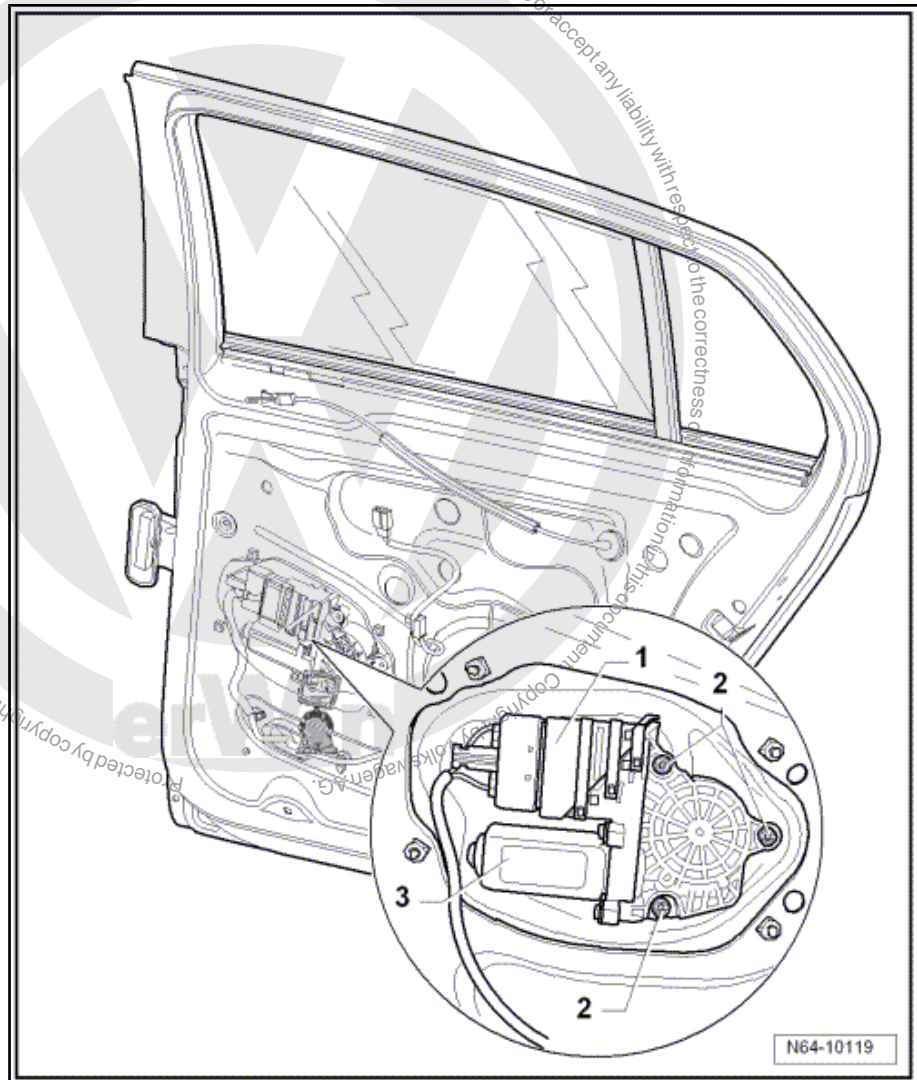

- Place window regulator motor -3- on and attach connector -1-.
- Move door window lightly up and down so that the splines between motor and cable drum engage easier.
- Tighten window regulator motor bolts -2-.
- Specified torque for bolts -2- 3.5 Nm
- Run window twice to upper stop and then down to lower stop. This normalises and readies the window, it also activates the pinch/roll-back function.

Then perform remaining installation in reverse order of removal.



3.8 Assembly overview - window regulator

 Note

The right side is shown. The left side is similar.

1 - Window regulator

- Removing and installing
⇒ [page 215](#)

2 - Bolt

- Qty. 4
- 8 Nm

3 - Mounting plate

4 - Drive

5 - Bolt

- Qty. 2
- 8 Nm

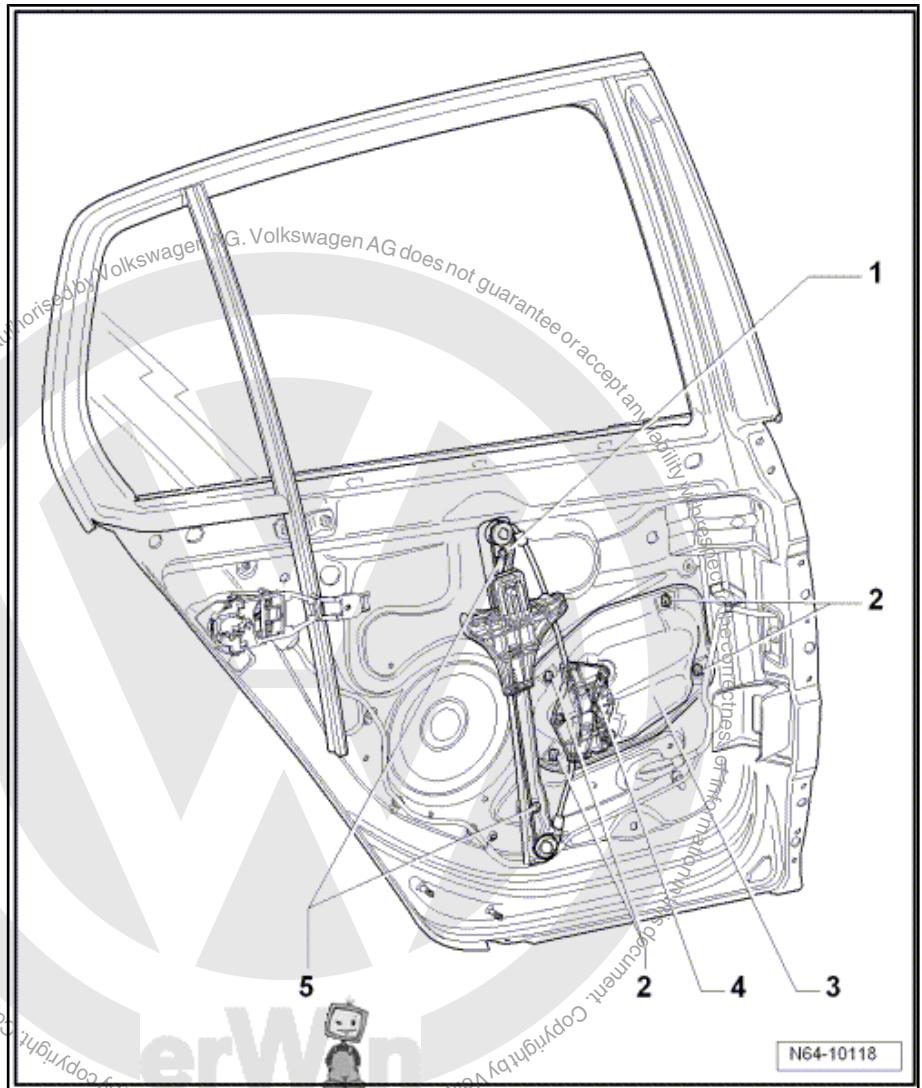

3.9 Removing and installing window regulator

 Note

The removal and installation sequence is only for the right window regulator. Removal and installation of the left window regulator is similar.



3.9.1 Removing

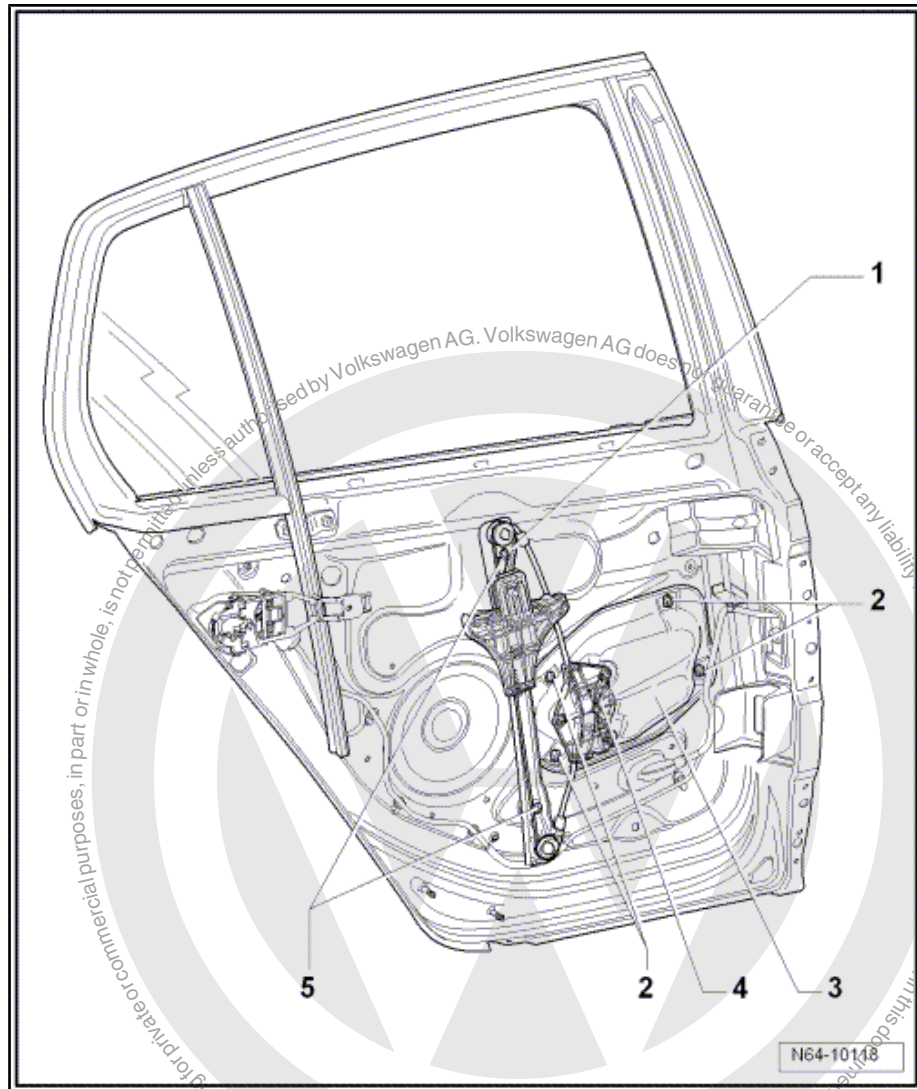

- Remove door outer panel ⇒ [page 94](#) .
- Remove impact protection ⇒ [page 111](#)
- Remove door window ⇒ [page 206](#) .
- Remove bolts -2- from mounting plate -3-.
- Remove window regulator bolts -5-.
- Remove window regulator -1- with drive -4- and window regulator motor mounting plate -3- off door inner part.
- Disconnect window regulator motor connector ⇒ [page 213](#)

3.9.2 Installing

Installation is carried out in reverse order of removal.

- Carry out functional check before installing door outer panel.



66 – Exterior equipment

1 Wheel housing liner

1.1 Tools

Special tools and workshop equipment required

- ◆ Torque wrench -V.A.G 1783-

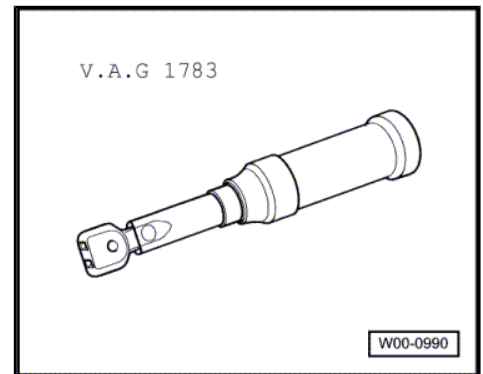



1.2 Assembly overview - front wheel housing liner



Note

- ◆ Only the left side is shown. The procedure for the right side is similar.
- ◆ The removal and installation procedures may have to be modified slightly depending on variations in equipment.
- ◆ The wheel housing liner consists of a front and a rear part.
- ◆ Vehicles with vermin repellent system ⇒ [page 276](#).

1 - Wheel housing liner rear part

- Material: PP/EPDM

2 - Bolt

- Qty. 7
- 2 Nm

3 - Wheel housing liner front part

- Material: PP/EPDM

4 - Bolt

- Qty. 11
- 2 Nm

5 - Spreader nut

- Qty. 6

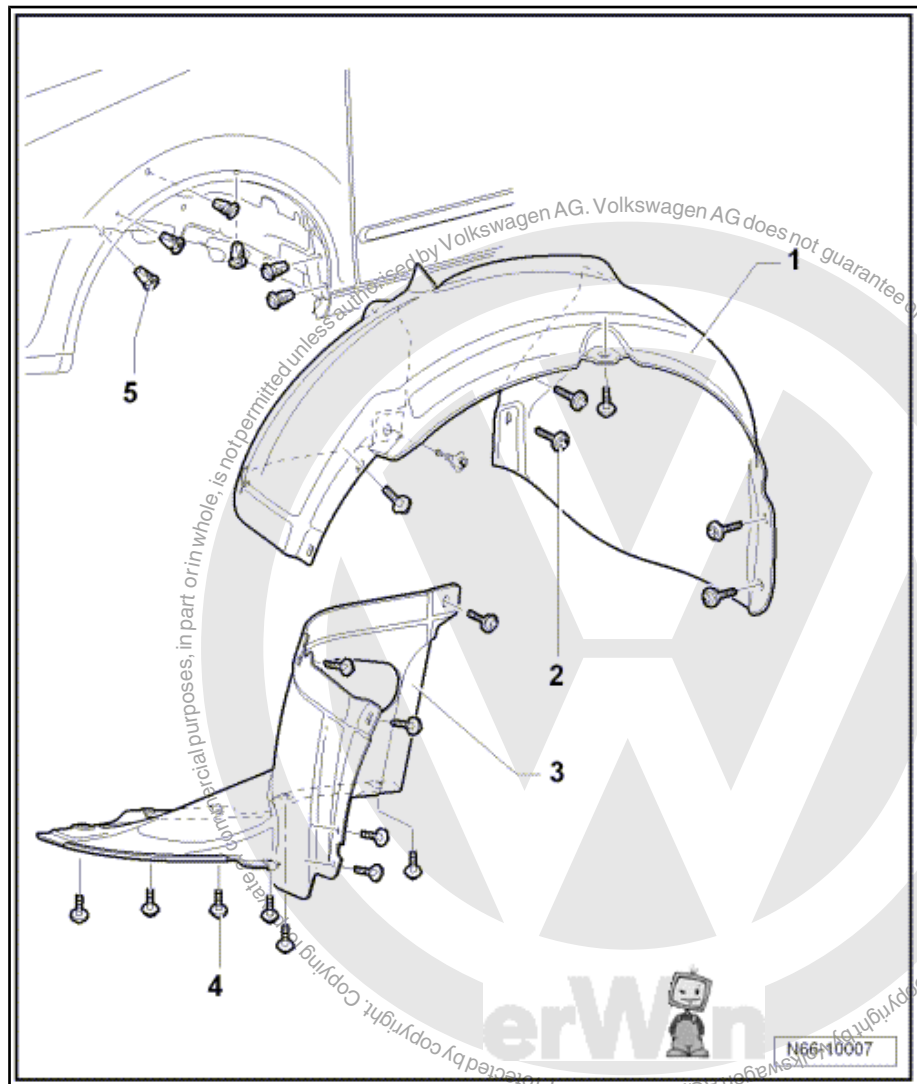

1.3 Removing and installing front wheel housing liner



Note

The removal and installation sequence is only for the left wheel housing liner. Removal and installation of the right wheel housing liner are similar.



1.3.1 Removing

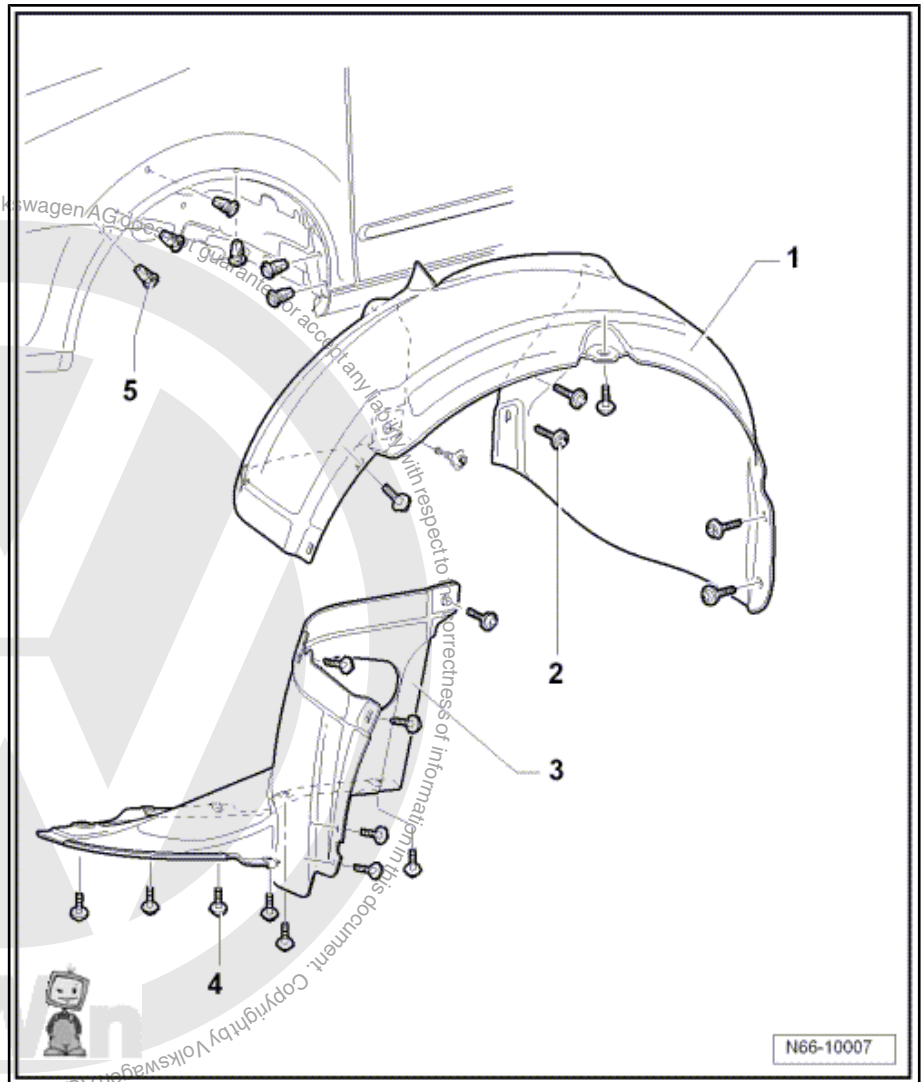

Wheel housing liner rear part

- Remove wheel ⇒ Running gear; Rep. Gr. 44 ; Specified torques for wheel bolts .
- Remove bolts -2- (Qty 7).
- Pull off rear part of wheel housing liner -1-.

Wheel housing liner front part

- Remove bolts -4- (Qty 11).
- Pull off front part of wheel housing liner -3-.

1.3.2 Installing

Installation is carried out in reverse order of removal.



1.4 Assembly overview - rear wheel housing liner



Note

Only the left side is shown. The procedure for the right side is similar.

1 - Wheel housing liner

- Material: PP/EPDM

2 - Bolt

- Qty. 9
- 2 Nm

3 - Spreader nut

- Qty. 4

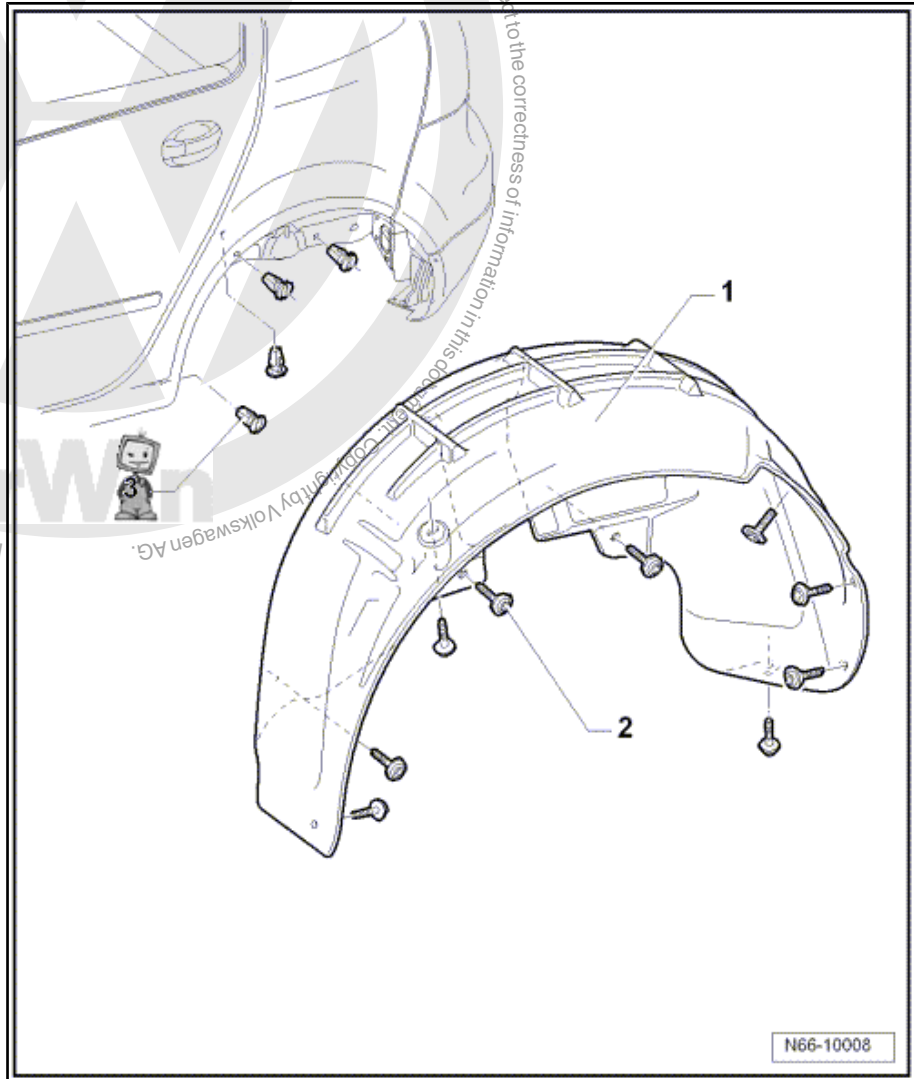

1.5 Removing and installing rear wheel housing liner



Note

The removal and installation sequence is only for the left wheel housing liner. Removal and installation of the right wheel housing liner are similar.



1.5.1 Removing

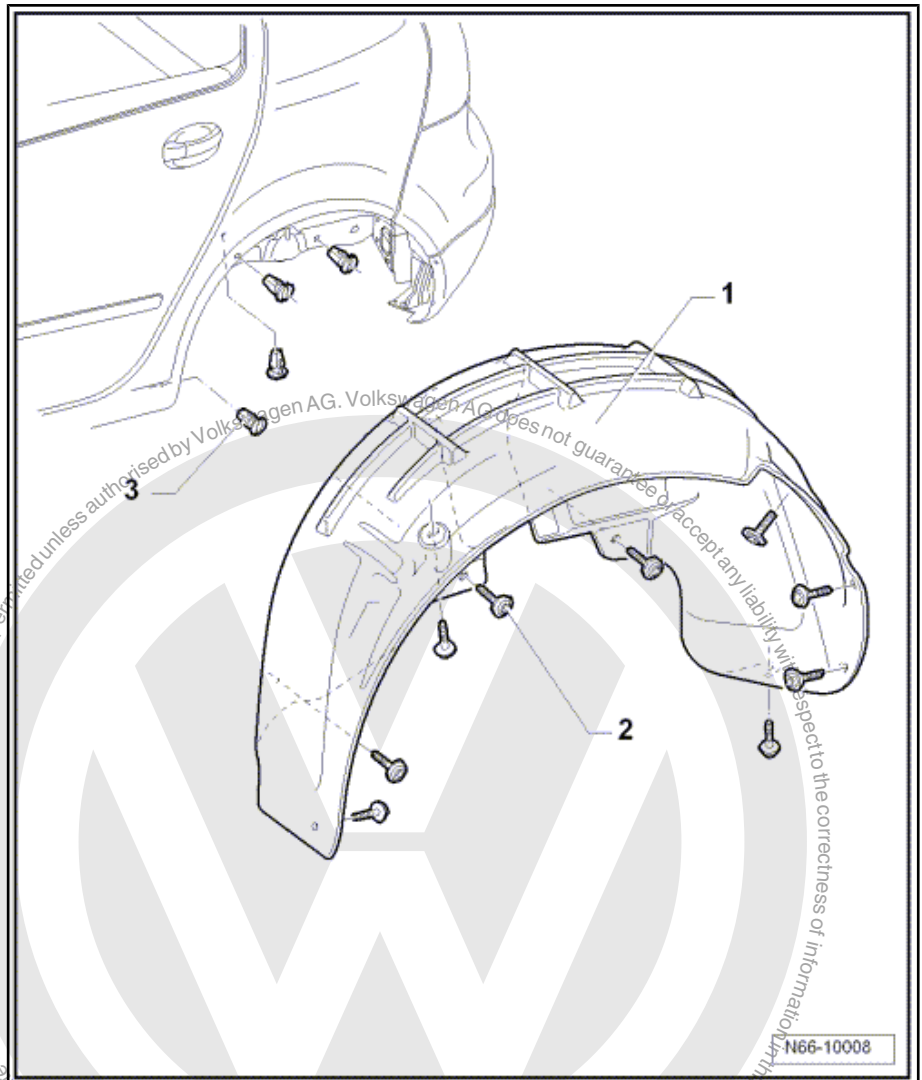

- Remove wheel ⇒ Running gear, Rep. Gr. 44 ; Specified torques for wheel bolts .
- Remove bolts -2- (Qty 9).
- Pull off wheel housing liner -1-.

1.5.2 Installing

Installation is carried out in reverse order of removal.



2 Exterior mirror

2.1 Tools

Special tools and workshop equipment required

- ◆ Removal lever -80-200-

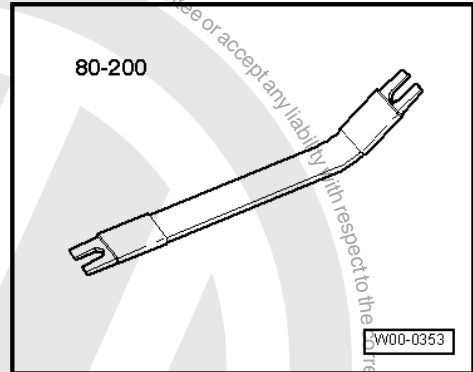

- ◆ Torque wrench -V.A.G 1783-

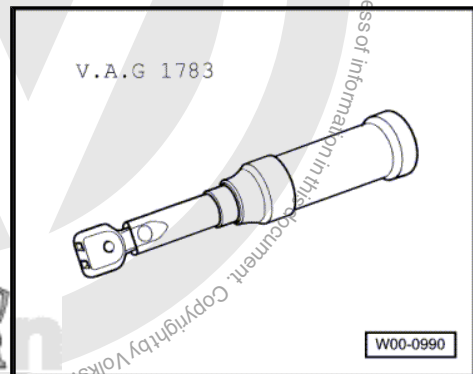



2.2 Assembly overview - exterior mirror

i Note

Only the left side is shown. The procedure for the right side is similar.

1 - Mirror mounting

- Removing and installing
 ⇒ [page 227](#)

2 - Bolt

- Qty. 3
- 8 Nm

3 - Assembly piece

- Removing and installing
 ⇒ [page 226](#)

4 - Bolt

- Qty. 2
- 1 Nm

5 - Bolt

- Qty. 2
- 1 Nm

6 - Side turn signal

- Removing and installing
 ⇒ [page 226](#)

7 - Trim

- Removing and installing
 ⇒ [page 226](#)

8 - Mirror glass

- Removing and installing
 ⇒ [page 223](#)

9 - Mirror housing

- Material: ABS
- Removing and installing
 ⇒ [page 224](#)

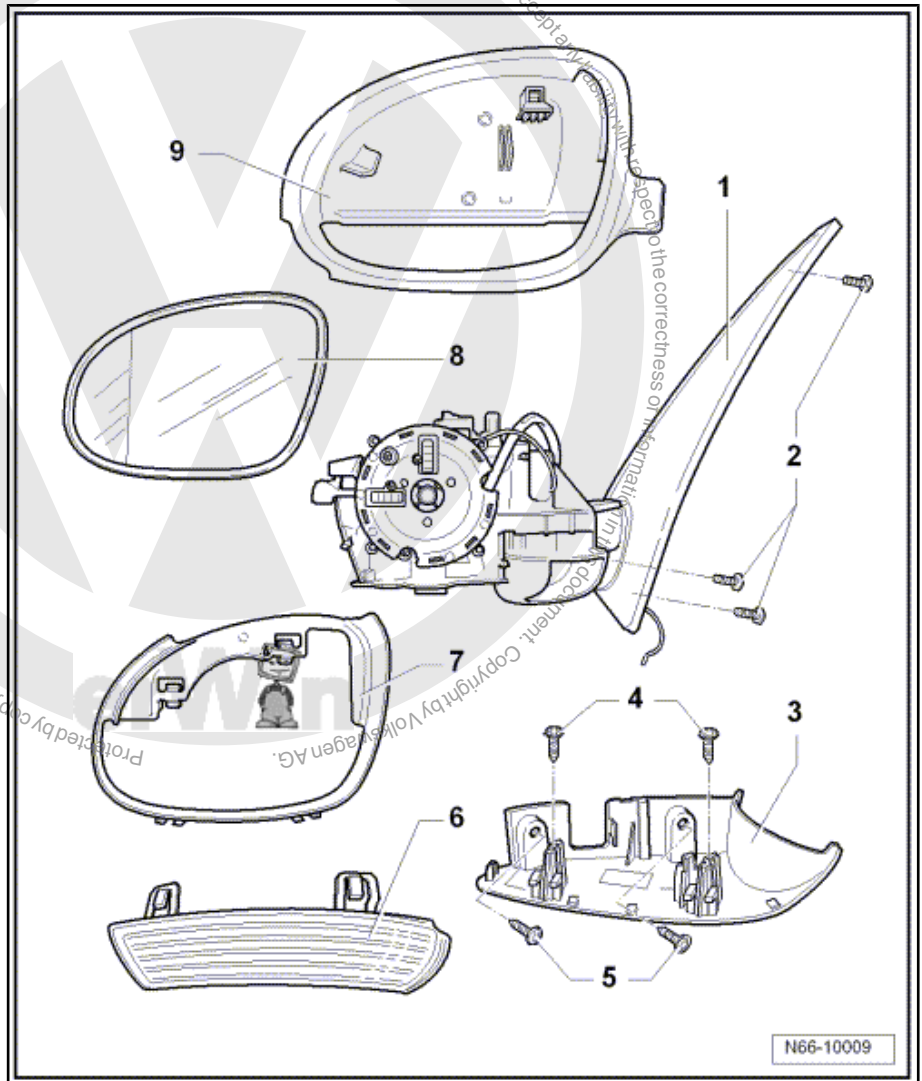

2.3 Removing and installing mirror glass

i Note

The removal and installation sequence is only for the left mirror glass. The removal and installation of the right mirror glass is similar.



WARNING

When doing this repair work, always wear protective goggles and leather gloves!



2.3.1 Removing

- Protect edge of housing -1- against paint damage with e.g. fabric-reinforced adhesive tape.
- Press bottom of mirror glass -2- into mirror housing -1-.
- Using removal lever -80 - 200- , press mirror glass -2- off bracket -5- and housing -1- -arrow 6-.
- Swivel mirror glass -2- to side -arrow 4- and detach connectors -3- for electric dip and mirror heating on rear of mirror glass -2-.

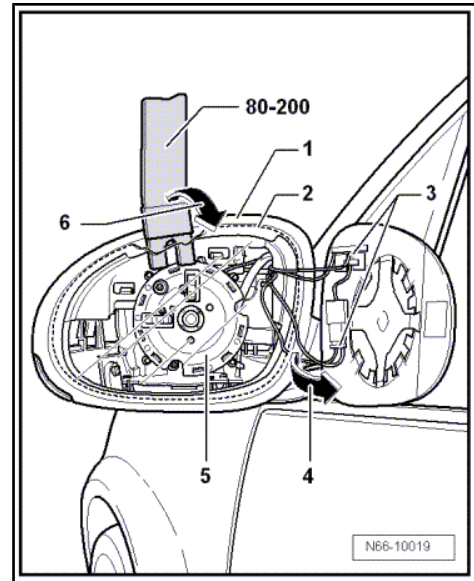

2.3.2 Installing

- Push contacts for mirror heating onto mirror glass.
- Press mirror glass centrally onto bracket in housing.
- Mirror glass engages audibly.
- Finally carry out a functional check.

2.4 Removing and installing mirror housing



Note

The removal and installation sequence is only for the left mirror housing. The removal and installation of the right mirror housing is similar.



2.4.1 Removing

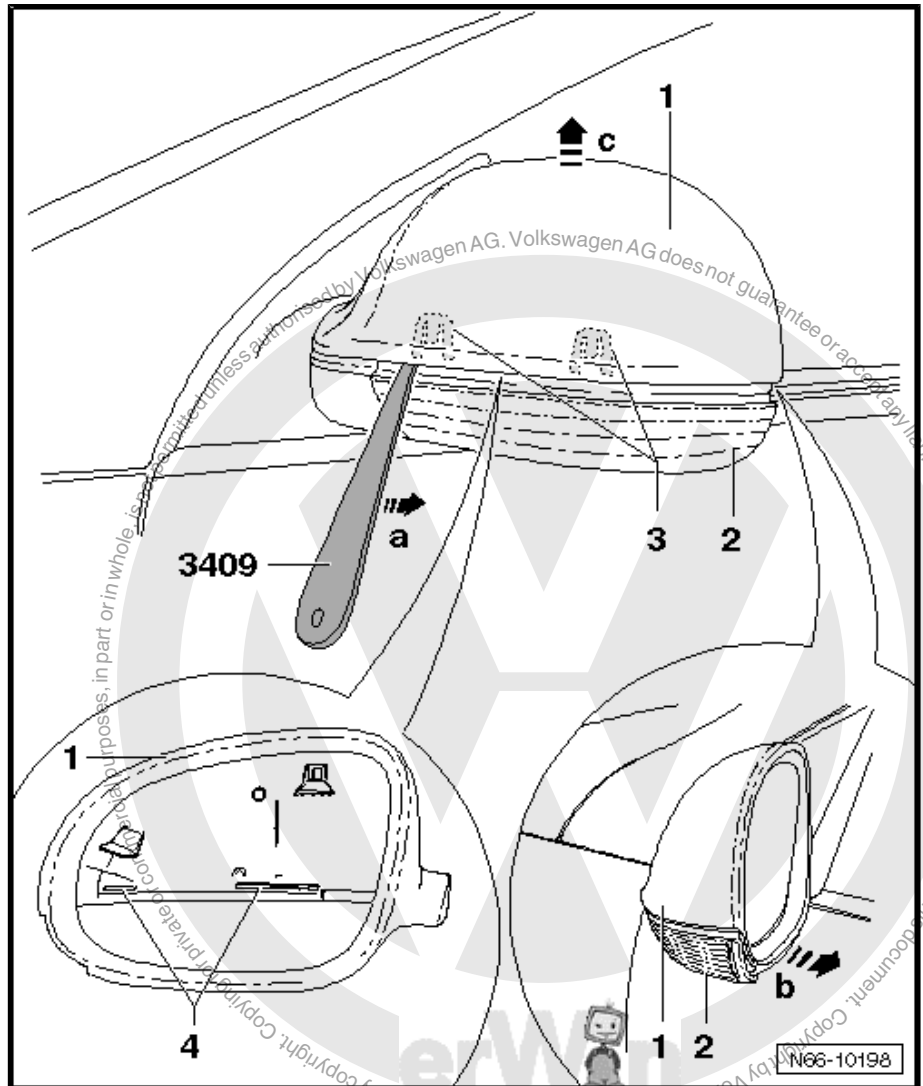

- Remove mirror glass ⇒ [page 224](#) .
- Insert removal wedge -3409- between mirror housing -1- and side turn signal -2-.
- Move removal wedge -3409- in -direction of arrow a- along to outer side of mirror.
- This releases latches for mirror housing -4- from locking hooks -3-.
- Pull mirror housing -1- forwards off mirror mounting at front in -direction of arrow b-.
- Remove mirror housing -1- upwards off mirror mounting in -direction of arrow c-.



2.4.2 Installing

- Place mirror housing -1- on mirror base carrier and press mirror housing down until the locking hooks -2- engage audibly.
- Install mirror glass again ⇒ [page 224](#)
- Finally carry out a functional check.

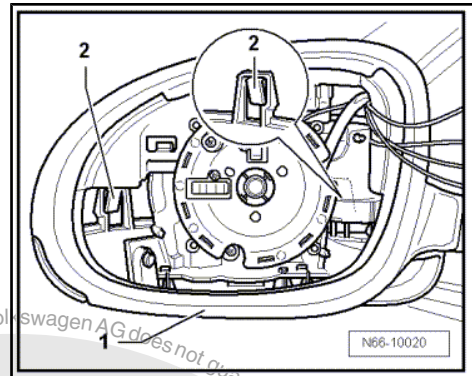

2.5 Removing and installing trim



Note

The removal and installation sequence is only for the left trim plate. The removal and installation of the right trim plate is similar.

2.5.1 Removing

- Remove mirror glass ⇒ [page 224](#) .
- Remove mirror housing ⇒ [page 224](#)
- Using a screwdriver lever locking hooks -2- out of mirror base carrier.
- Pull trim plate -1- off in -direction of arrow-.

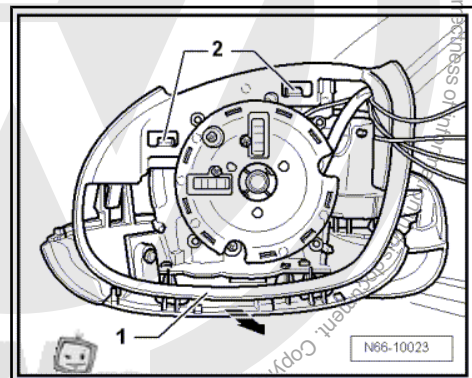

2.5.2 Installing

Installation is carried out in reverse order of removal.

- Finally carry out a functional check.

2.6 Removing and installing side turn signals



Note

- ◆ *The removal and installation sequence is only for the left side mounted turn signal. The removal and installation of the right side mounted turn signal is similar.*
- ◆ *There are no conventional bulbs but rather durable light emitting diodes (LEDs) installed in the side turn signals.*
- ◆ *Therefore, changing bulbs is not necessary. In case of damage, the entire turn signal must be renewed.*



2.6.1 Removing

- Remove mirror glass ⇒ [page 223](#) .
- Remove mirror housing ⇒ [page 224](#)
- Remove trim ⇒ [page 226](#) .
- Remove bolts -4- and remove assembly piece -1- downwards.
- Detach connector -5- from turn signal -3-.
- Remove bolts -2- and take turn signal -3- off assembly piece -1-.

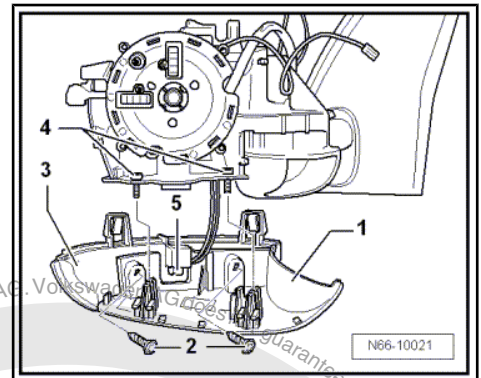

2.6.2 Installing

Installation is carried out in reverse order of removal.

- Finally carry out a functional check.

2.7 Removing and installing exterior mirror



Note

The removal and installation sequence is only for the left exterior mirror. The removal and installation of the right exterior mirror is similar.

2.7.1 Removing

- Remove front door trim on driver side ⇒ General body repairs, interior; Rep. Gr. 70 ; Trims, insulation; Removing and installing front door trim on driver side .
- Release cable retainer -2- and detach connector -1- for exterior mirror.

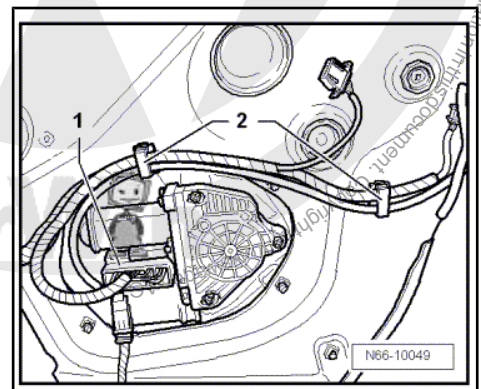

- Lever cap -3- out of door and remove bolts -2-.
- Remove exterior mirror -1- and guide wire through aperture in door.

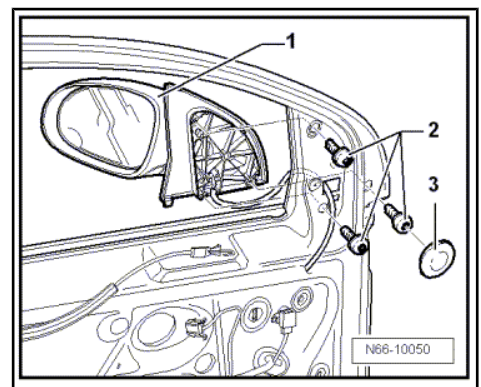



2.7.2 Installing

Installation is carried out in reverse order of removal.

- Specified torque for exterior mirror bolts: 8 Nm
- Test function before installing door trim.





3 Radiator grille

3.1 Tools

Special tools and workshop equipment required

- ◆ Torque wrench - V.A.G 1783-

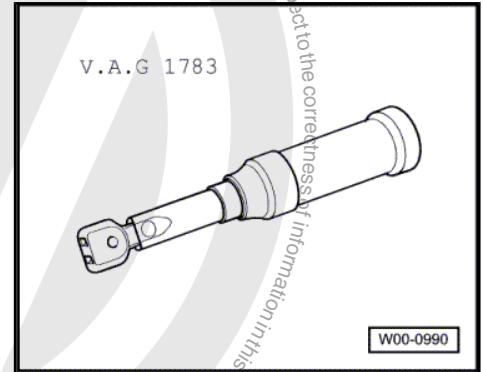

3.2 Assembly overview - radiator grille

1 - Radiator grille

- Material: ASA

2 - Retaining hook

- Qty. 6

3 - VW emblem

- Clipped into radiator grille
- Only remove when the radiator grille is removed
- Removing: release locking hooks on rear of VW emblem with radiator grille removed.
- Installing: guide VW emblem with locking hooks into recesses in radiator grille -arrow b-, then turn slightly in direction of -arrow c- until VW emblem engages in radiator grille.

4 - Bolt

- Qty. 2
- 2 Nm

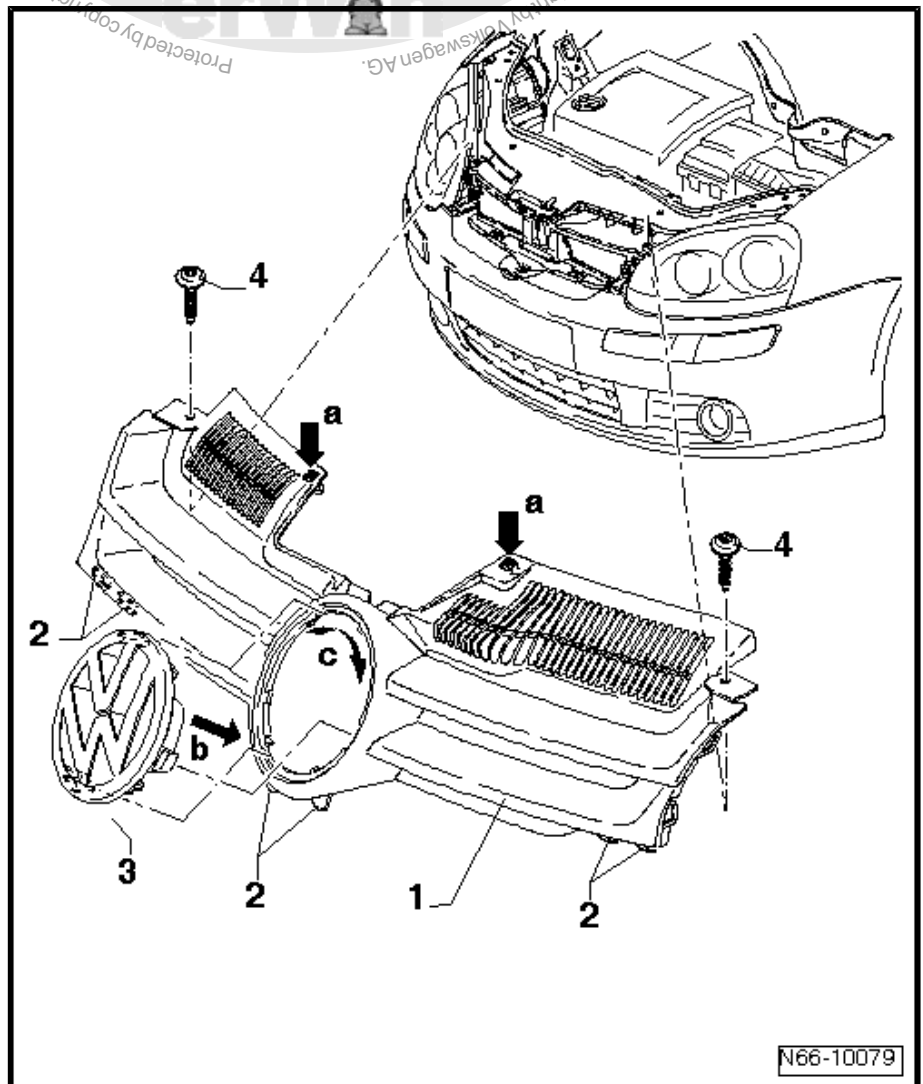

N66-10079



3.3 Removing and installing radiator grille

3.3.1 Removing

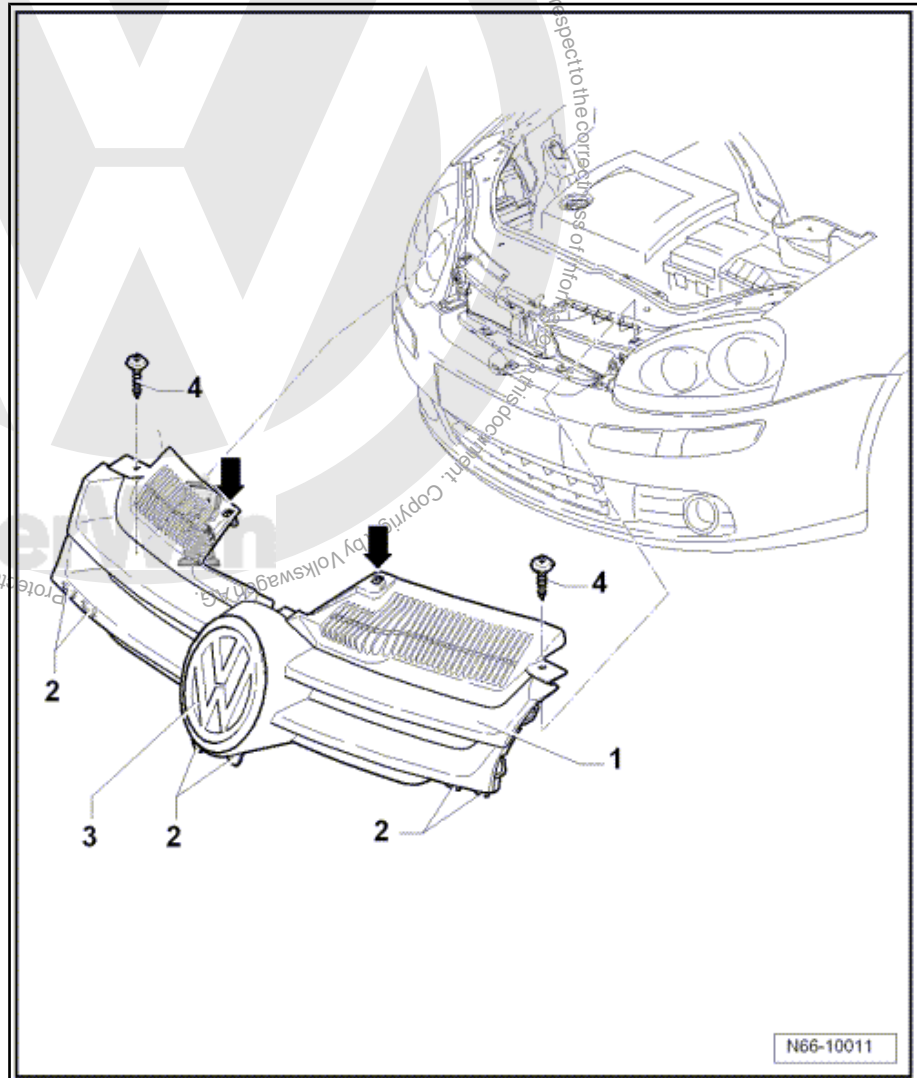

- Remove bolts -4-.
- Release clips -arrows- on lock carrier using a small screwdriver.
- Tilt radiator grille -1- backwards slightly and pull locking hooks -2- upwards out of bumper cover.



3.3.2 Installing

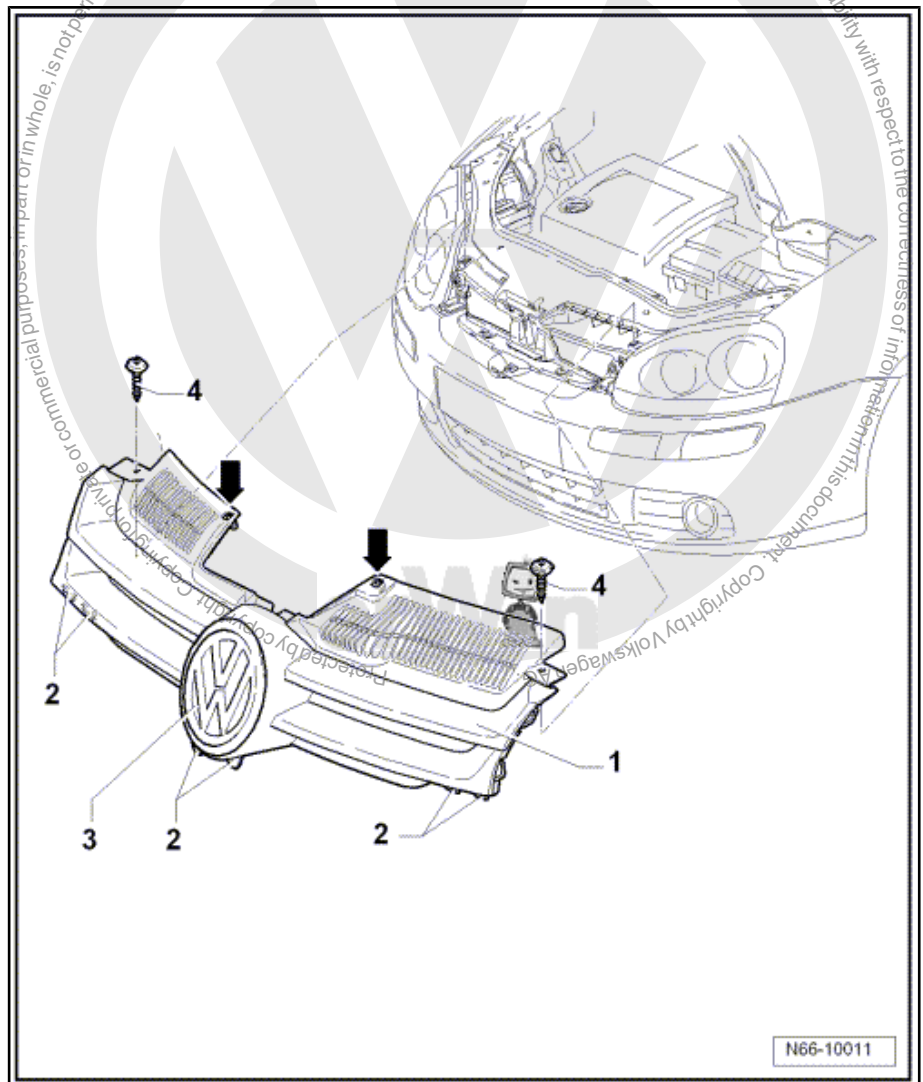

- With radiator grille-1- tilted forward slightly place locking hooks -2- in the bumper cover.
- Clip radiator -1- to lock carrier and engage clips -arrows- in lock carrier.
- Install bolts -4-.

3.4 Assembly overview - radiator grille for GTI, GTI special models and GT

i Note

- ◆ *Minor differences will be encountered on removal and installing, depending on version.*
- ◆ *The radiator grilles for the Golf GT and the Golf GTI differ only in their appearance.*
- ◆ *The radiator grille for the Golf GTI has a honeycomb pattern, the radiator grille for the Golf GT has transverse pieces.*



1 - Radiator grille

- Different appearance for Golf GT and Golf GTI
- Material: ASA

2 - Bolt

- Qty. 2
- 2 Nm

3 - Decorative trim

- Only for Golf GTI
- Engaged in radiator grille

4 - Spreader rivet

- Qty. 4

5 - Number plate carrier

- For various countries
- Secured to radiator grille with spreader clips
- For radiator grille with no securing holes
=> [page 235](#)

6 - VW emblem

- Clipped into radiator grille
- Only remove when the radiator grille is removed
- Removing: release locking hooks on rear of VW emblem with radiator grille removed.
- Installing: guide VW emblem with locking hooks into recesses in radiator grille -arrow b-, then turn slightly in direction of -arrow c- until VW emblem engages in radiator grille.

7 - Front GTI lettering

- Engaged in radiator grille
- Only remove when the radiator grille is removed
- Unhook locking hooks from rear

8 - Bolt

- Qty. 2
- 2 Nm

9 - Retaining hook

- Qty. 2

10 - Guide hook

- Qty. 4

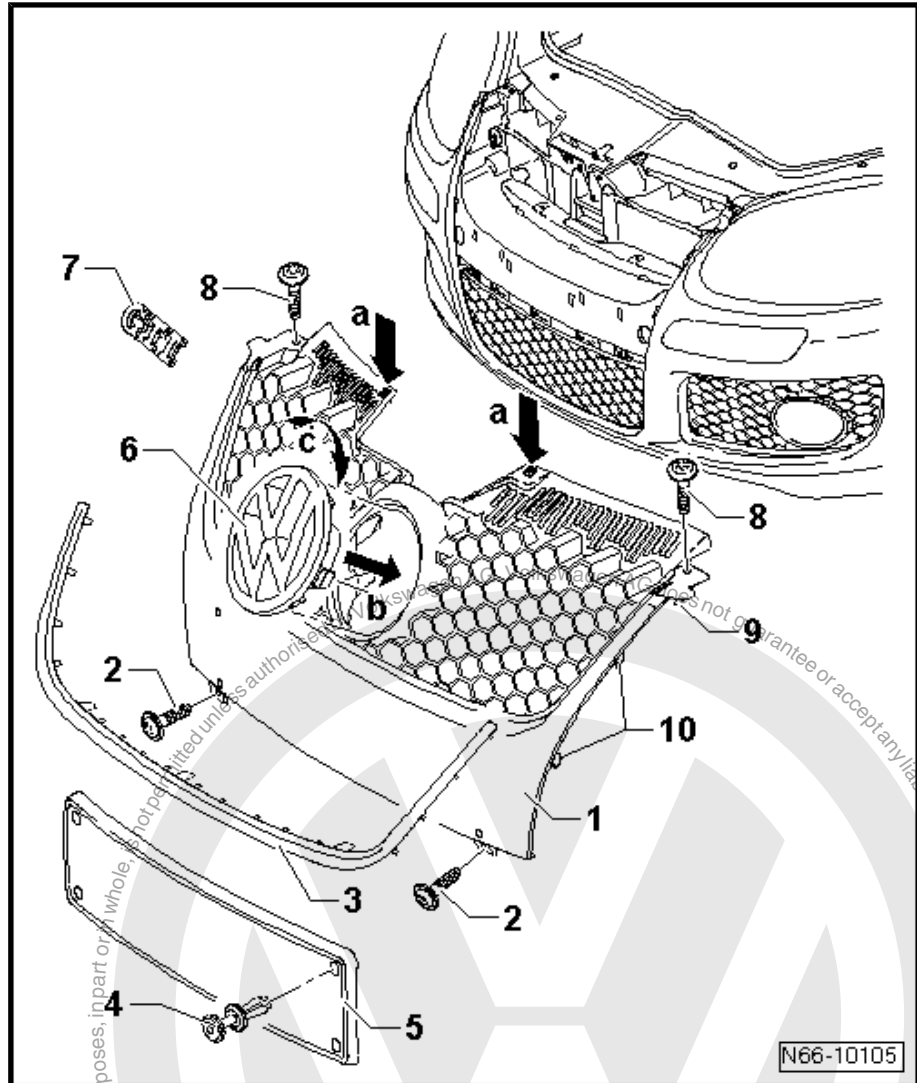



3.5 Removing and installing radiator grille for GT, GTI special models and GT

i Note

The radiator grilles for the Golf GT and the Golf GTI differ only in their appearance.

3.5.1 Removing

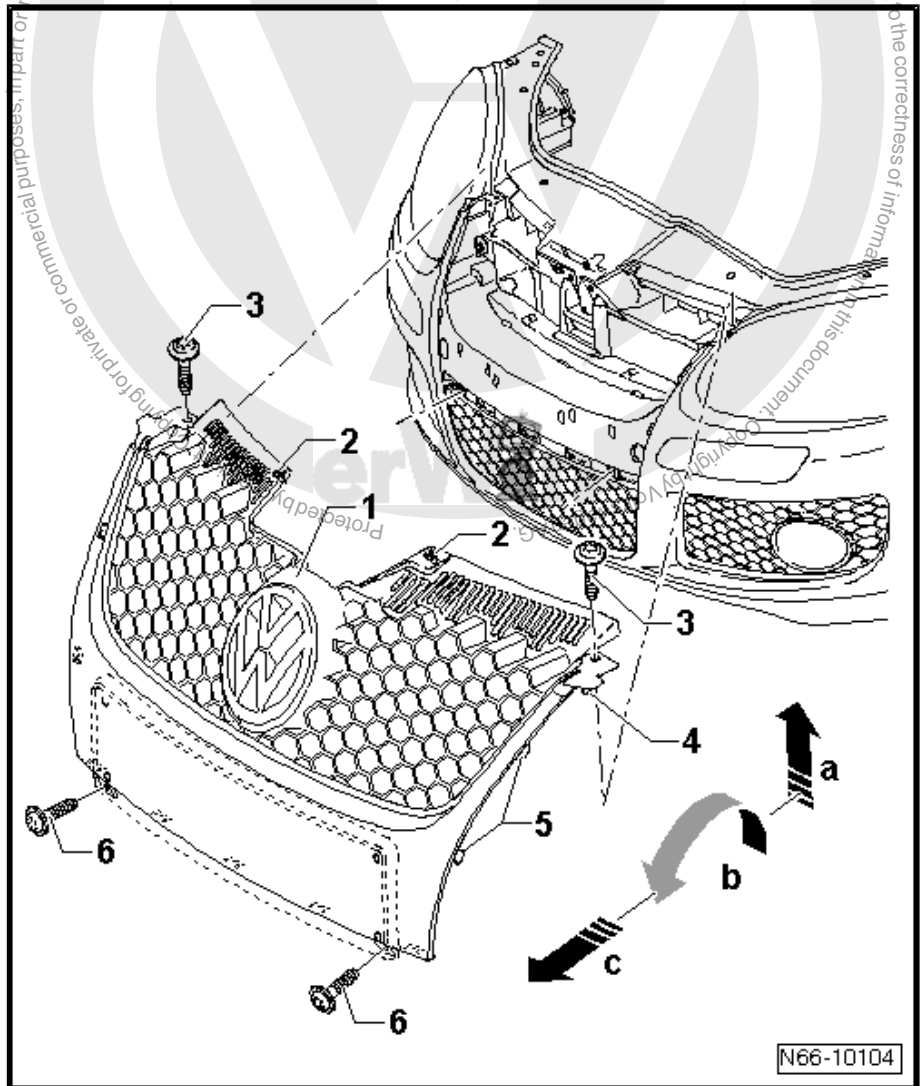

- Remove bolts -3- and -6-.
- Loosen locking hooks -2- and -4-.
- Lift radiator grille -1- up -arrow a- out of guide hooks -5-.
- Tilt upper edge of radiator grille forwards -arrow b-.
- Pull radiator grille out of bumper cover -arrow c-.



3.5.2 Installing

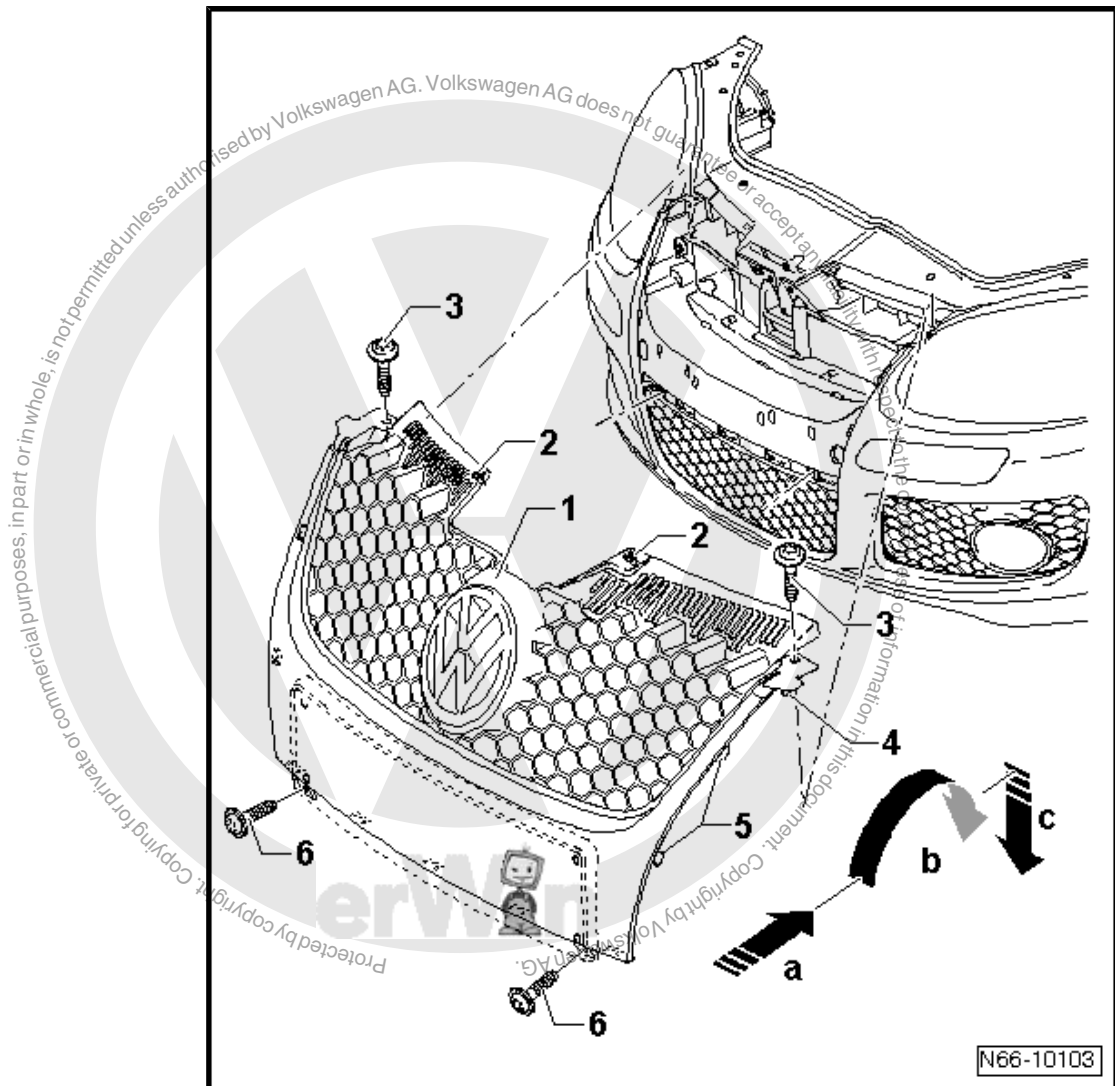

- Insert lower edge of radiator grille horizontally into bumper cover -arrow c-.
 - Fold radiator grille upwards -arrow b-.
 - Guide radiator grille into guide hooks -5- from above -arrow c-.
- Locking hooks -2- and -4- engage audibly.
- Tighten bolts -3- and -6-, specified torque: 2 Nm.



3.6 Radiator grille for GTI, GTI special models, GT and R32 - number plate carrier

1 - Radiator grille

- With no securing holes.

2 - Number plate carrier

- For various countries
- Observe country specific legislative dimensions
- Installing
 - Align number plate carrier -3-, mark position of holes and drill-out
 - Secure number plate carrier with clips

3 - Centre line

4 - Clip

- Qty. 4

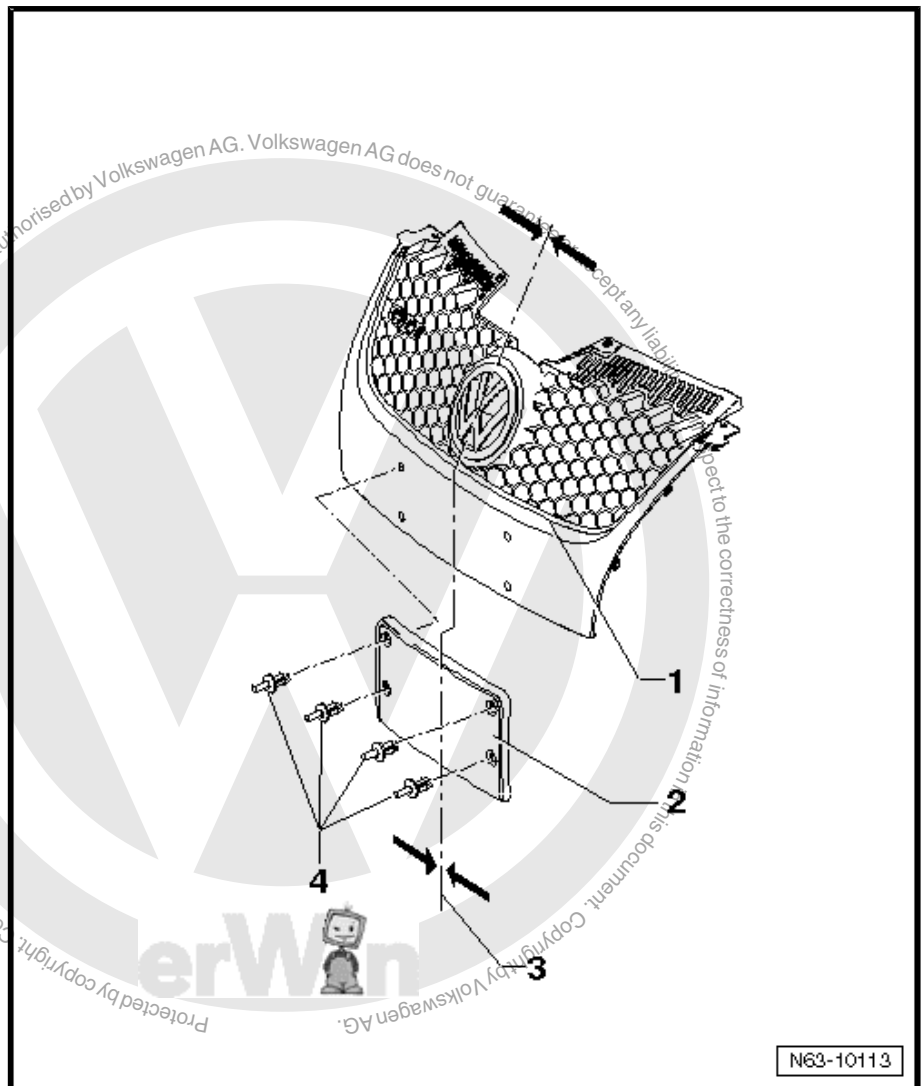



3.7 Assembly overview - radiator grille for R32

1 - Radiator grille

- Material: ASA
- Removing:

2 - Left air intake grille

- Removing: ⇒ [page 237](#)

3 - Bolt

- Qty. 6 per side
- 1 Nm

4 - Bolt

- Qty. 4
- 2 Nm

5 - Number plate carrier

- For various countries
- Secured to radiator grille with spreader clips
- For radiator grille with no securing holes ⇒ [page 235](#)

6 - Spreader rivet

- Qty. 4

7 - Left air intake grille

- Removing: ⇒ [page 237](#)

8 - VW emblem

- Clipped into radiator grille
- Only remove when the radiator grille is removed
- Removing: ⇒ [page 239](#)

9 - R32 front lettering

- Engaged in radiator grille
- Only remove when the radiator grille is removed
- Removing: ⇒ [page 239](#)

10 - Decorative trim

- Engaged in radiator grille

11 - Bolt

- Qty. 2
- 1 Nm

12 - Bumper cover

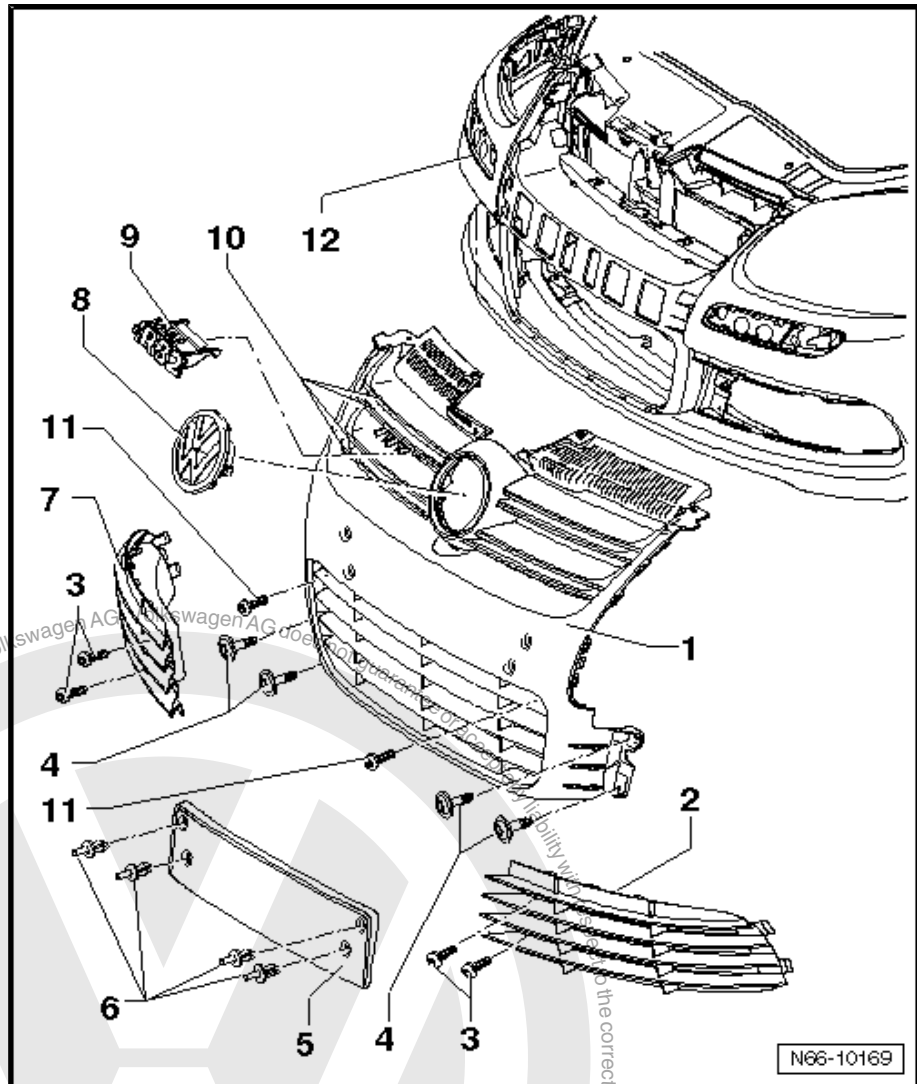

3.8 Removing and installing radiator grille for R32

3.8.1 Removing

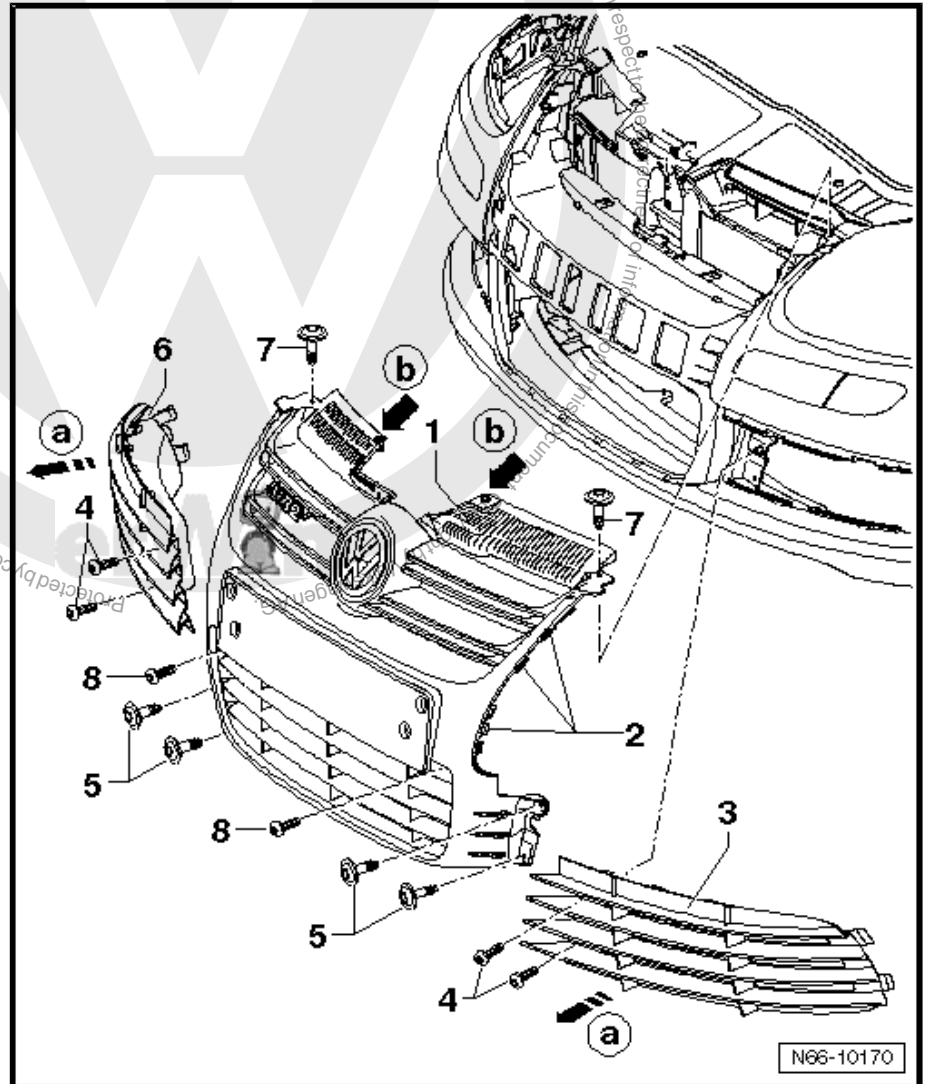

- Remove bolts -4- and pull air grilles -3 and 6- in -direction of arrow a- and out of retaining clips in bumper cover.
- Remove bolts -5, 8 and 7-.
- Release locking hooks -arrow b- and pull radiator grille -1- out of side locking devices -2- in bumper cover.



3.8.2 Installing

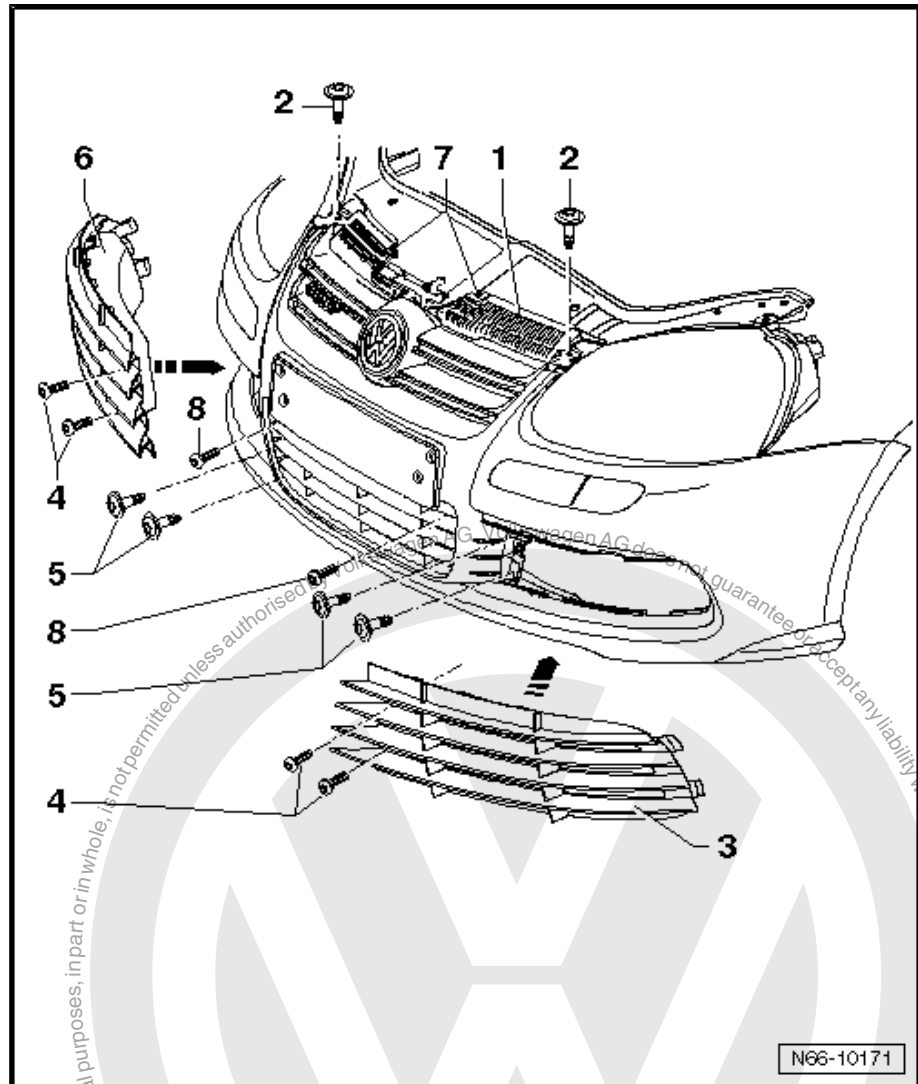

- Place radiator grille -1- in bumper cover.
- The side locking devices and locking hooks -7- must engage audibly.
- Tighten bolts, specified torque for bolts -2- and -5-: 2 Nm and bolt -8-: 1 Nm.
- Press air grilles -3 and 6- into bumper cover.
- Tighten bolts, specified torque for bolt -4-: 1 Nm.



3.9 R32 radiator grille - company emblem

1 - VW emblem

- Removing:
 - Release locking lugs -arrow c-
- Installing:
 - Position company emblem -arrow a- and turn in -direction of arrow b-

2 - R32 lettering

- Removing:
 - Release locking lugs -arrow d-

- Installing:
 - Press into mounting in radiator grille until the locking lugs -arrow d- engage

3 - Radiator grille

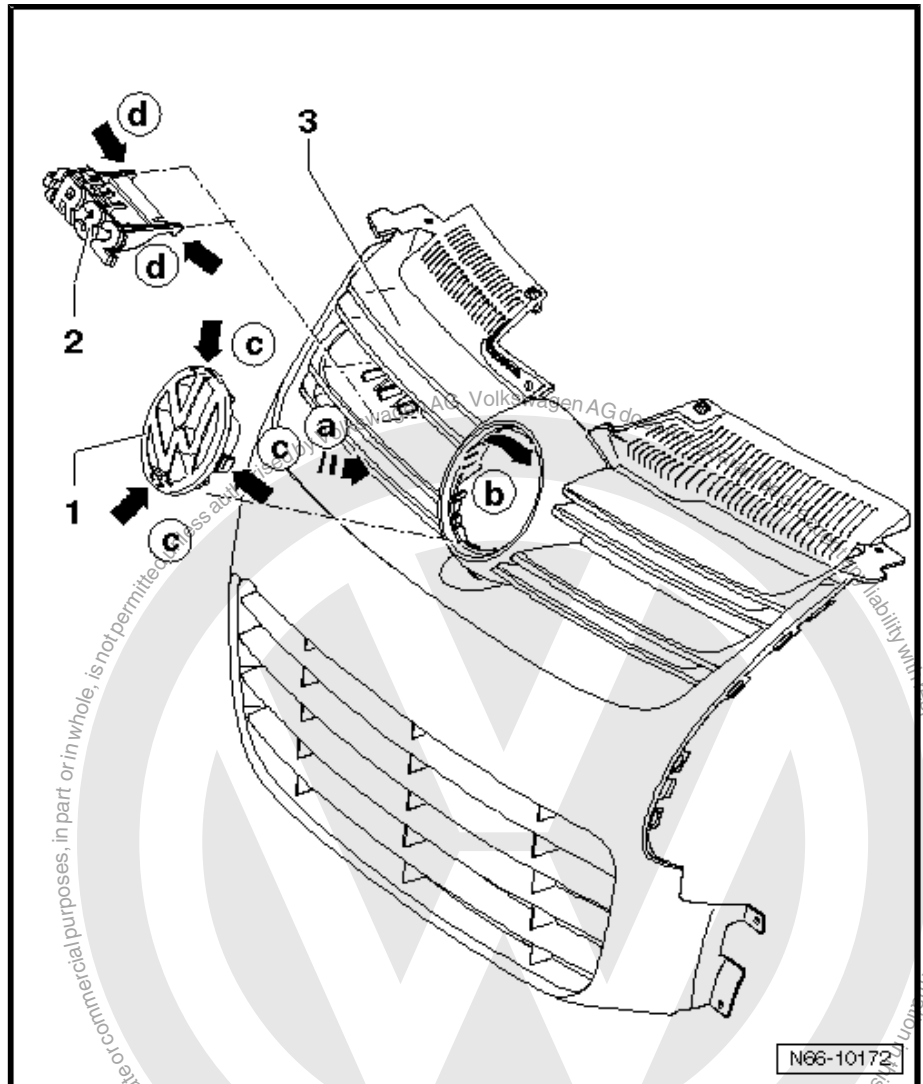



4 Mouldings and trims

4.1 Tools

Special tools and workshop equipment required

- ◆ Torque wrench -V.A.G 1783-

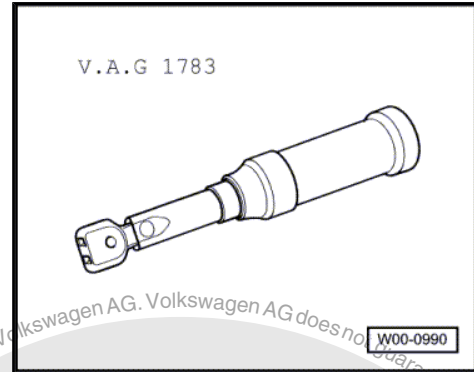

- ◆ Hot air blower -V.A.G 1416-

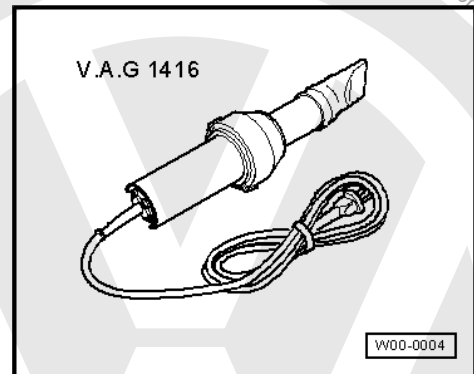



4.2 Assembly overview - water deflector

 Note

The right side is shown. The left side is similar.

- 1 - Water deflector
- 2 - Retaining strip
- 3 - Pop rivet
 - Qty. 5
- 4 - Clip
- 5 - Bracket

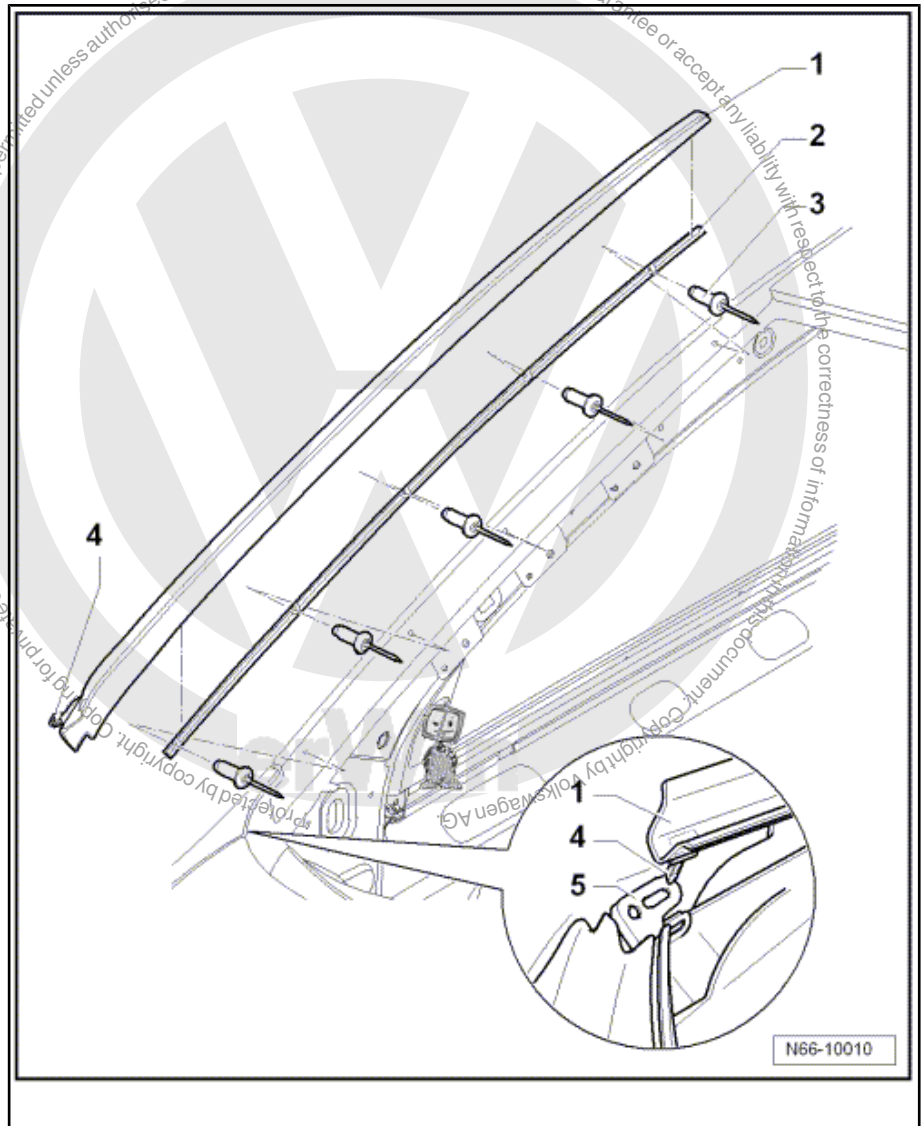



4.3 Removing and installing water deflector

4.3.1 Removing

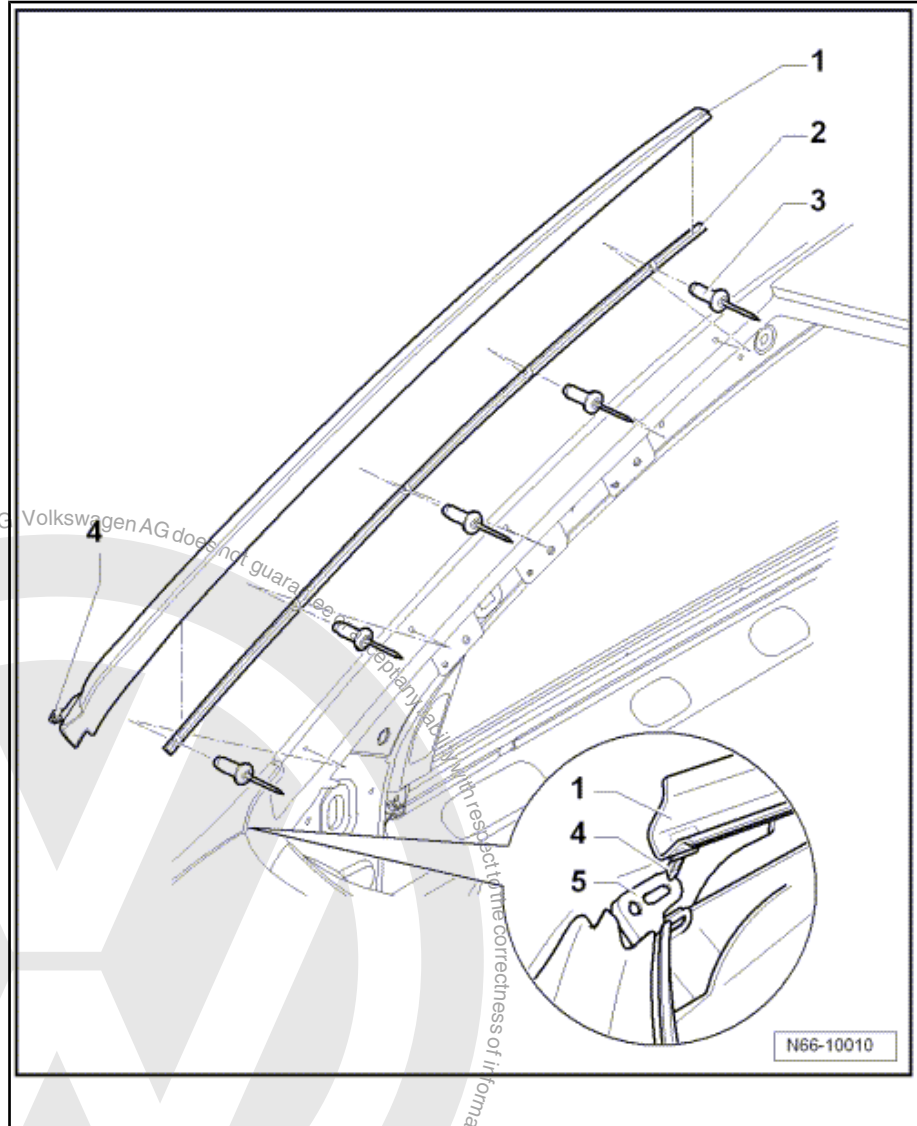

- Lever water deflector -1- out of retaining strip -2- starting at top.
- Pull clip -4- out of retainer -5- in lower area of wing.



4.3.2 Installing

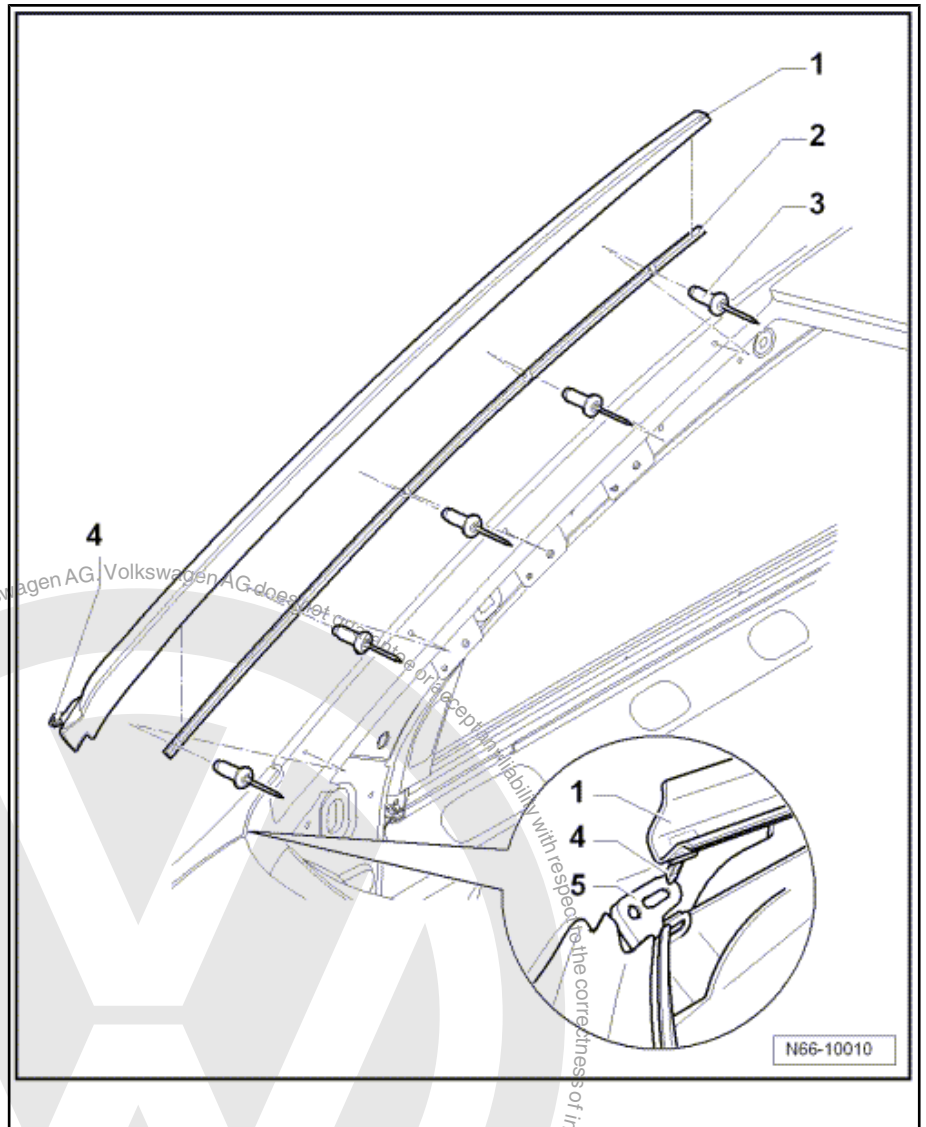

- Attach clip -4- in retainer -5-.
- Press water deflector -1- into retaining strip -2- from bottom to top.



4.4 Assembly overview - protective side strips



Note

Only the left side is shown. The procedure for the right side is similar.

1 - Front door protective side strip

- Material PP/EPDM
- Self-adhesive
- Left and right protective side strips have different hole patterns

2 - Side panel protective side strip

- Material PP/EPDM
- Self-adhesive
- Left and right protective side strips have different hole patterns

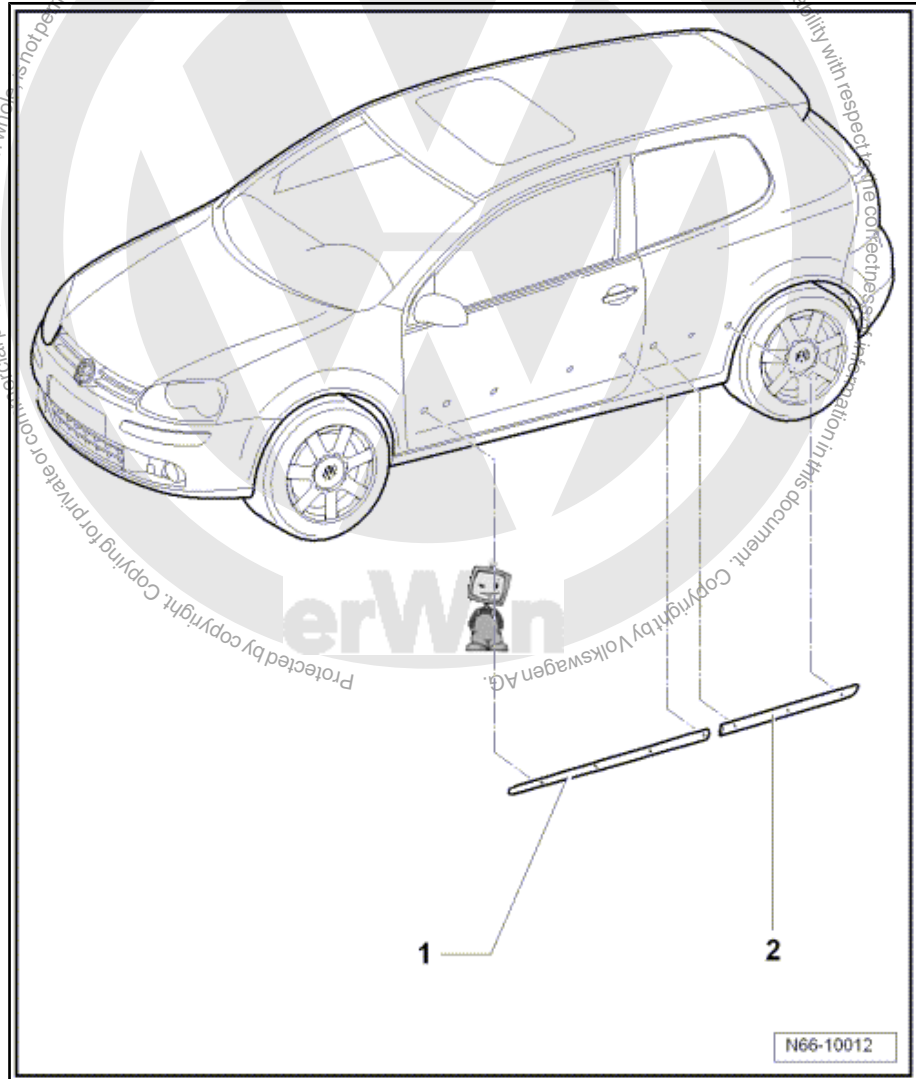



4.5 Renewing side protective mouldings



Note

- ◆ Installation is only described for the left side. The procedure for the right side is similar.
- ◆ Remove protective backing immediately before installation. Working temperature approx. 21 °C
- ◆ Curing time after attaching side protective strips is about 4 hours at a room temperature of about 21° C.
- ◆ Adhesive remover D 002 000 10 must be used exclusively.
- ◆ The side protective strips must be bonded in place immediately after cleaning.

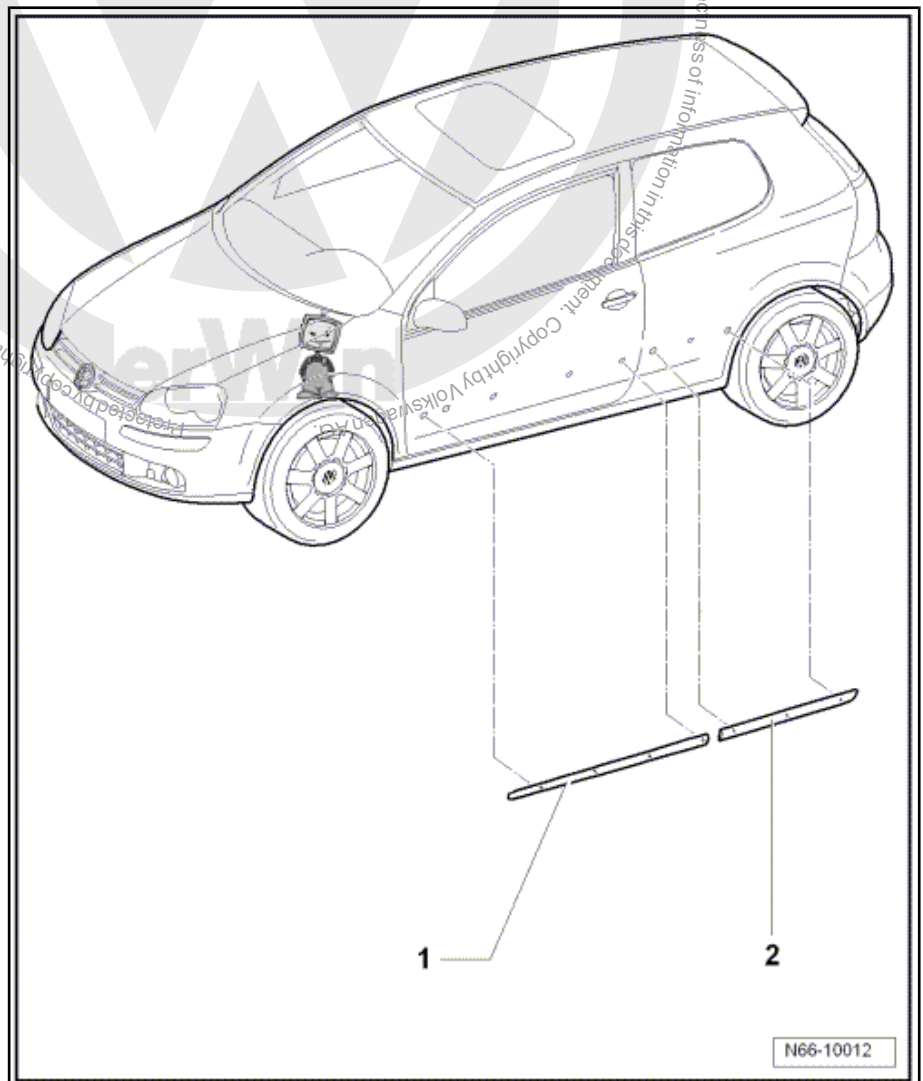

- Before removing, heat protective side strips -1- and -2- with a hot air blower -V.A.G 1416- and pull protective side strips off.
- Remove existing adhesive residues with adhesive remains remover -VAS 6349- .
- Immediately before bonding the side protective strips, clean bonding surface thoroughly with adhesive remover D 002 000 10.



- Only remove protective backing from side protective strips -1- and -2- immediately before fitting.
- Bonding surfaces must be free of dust and grease.
- Position protective side strips -1- and -2- on vehicle and press on using force.

4.6 Removing and installing stone-chip protection trim

4.6.1 Removing

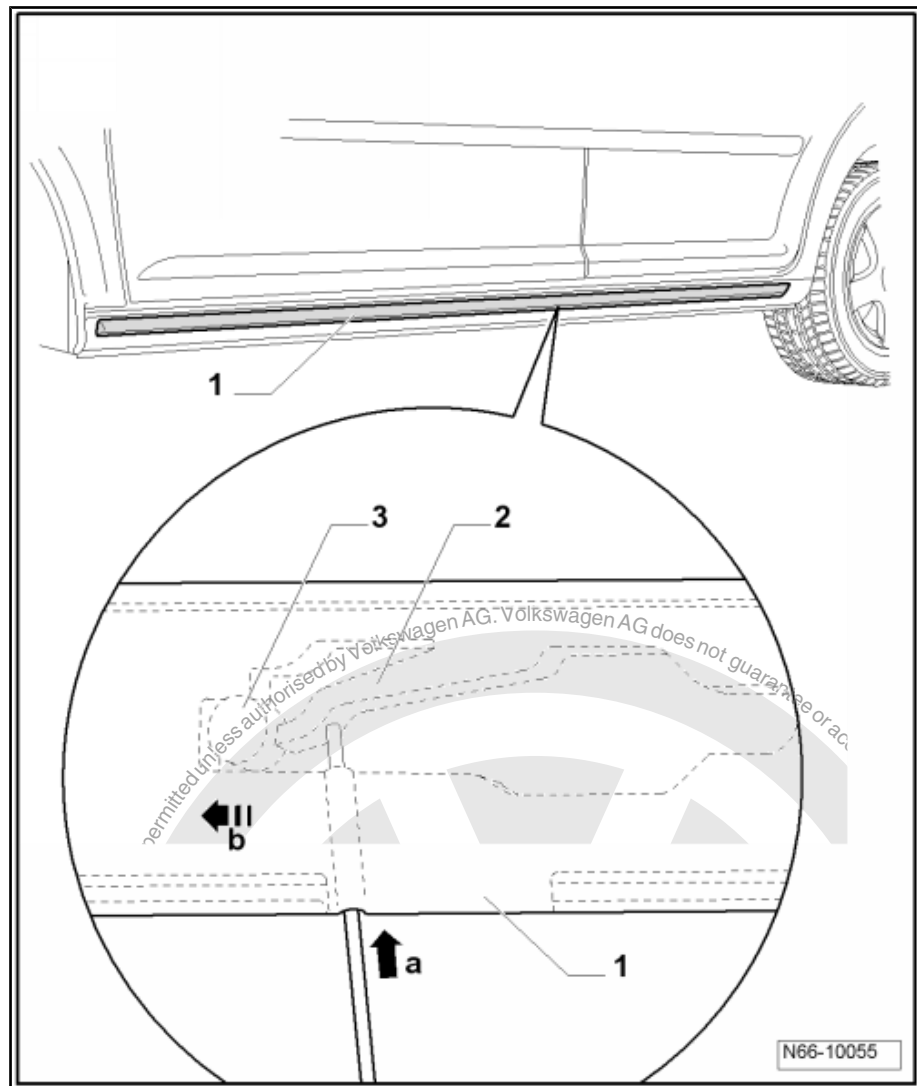

- Guide a small screwdriver through the opening on the bottom edge of the side trim and release the locking device -2-, by pressing the screwdriver upwards -arrow a-.
- Slide stone chip protection trim -1- forwards -arrow b- until the screwdriver contacts the securing screw -3-. Now pull screwdriver out. Slide stone-chip protection trim further until the stone-chip protection trim can be removed from all securing screws.



4.6.2 Installing

i Note

- ◆ *The stone-chip protection trim securing screws are corrosion-resistant. No further secondary treatment is required.*
- ◆ *If a screw is overtightened, it is essential to replace it with a "black" oversize screw.*

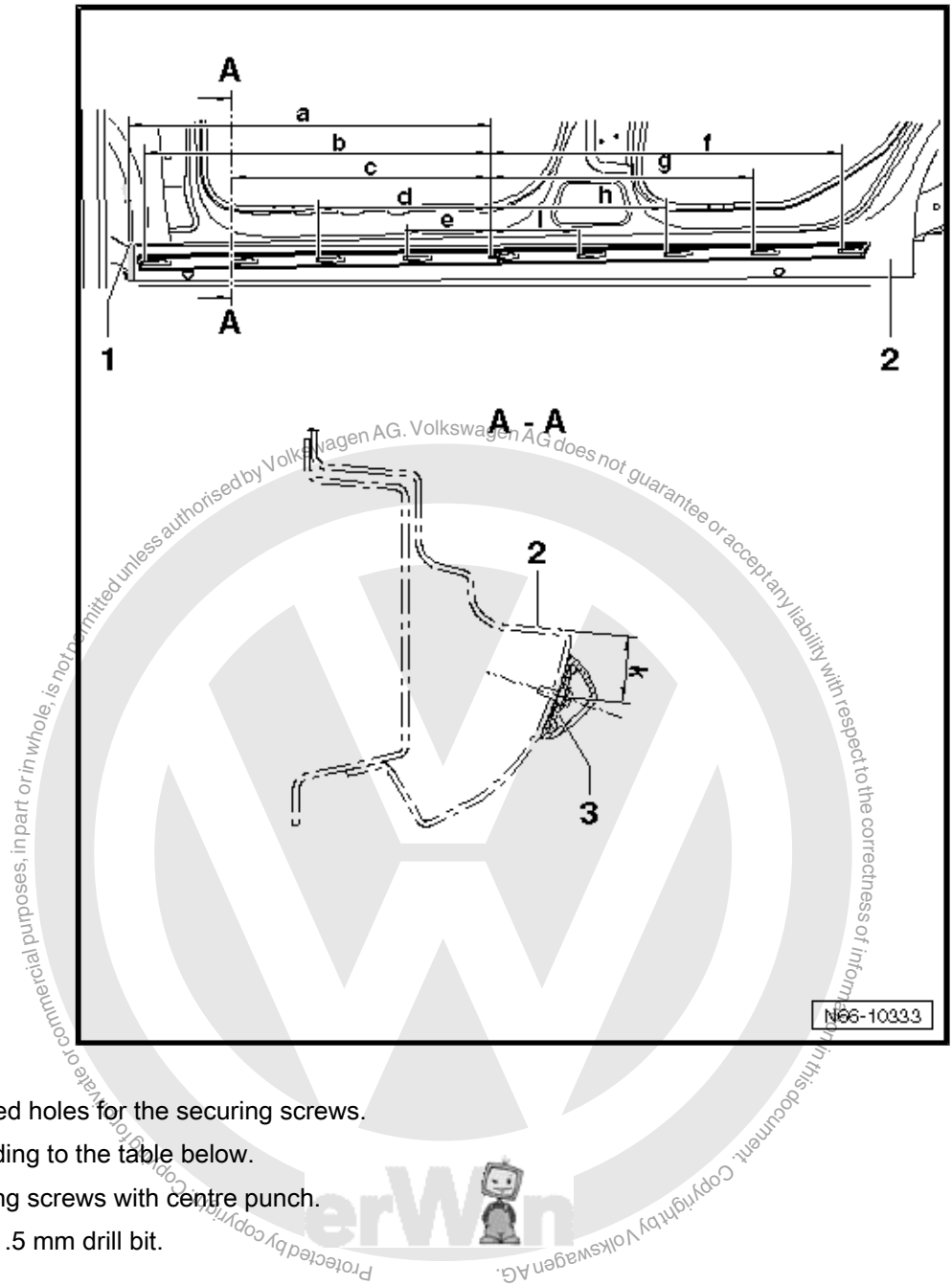

- There are no pre-drilled holes for the securing screws.
- Measure holes according to the table below.
- Mark holes for securing screws with centre punch.
- Drill out holes with a 1.5 mm drill bit.



Note

- ◆ *Dimension -a- is measured including wheel housing liner -2-. The other dimensions -b through i- are always measured from the centres of the holes.*
- ◆ *Dimension -k- can only be measured on 4-door vehicles.*
- ◆ *For two-door vehicles, determine dimension -k- in height to the front holes.*

The table follows.

Dimension -a-	= 855 mm
Dimension -b-	= 822 mm
Dimension -c-	= 617 mm
Dimension -d-	= 411 mm
Dimension -e-	= 205 mm
Dimension -f-	= 205 mm
Dimension -g-	= 411 mm
Dimension -h-	= 617 mm
Dimension -i-	= 822 mm
Dimension -k-	= 35 mm

That was the table.

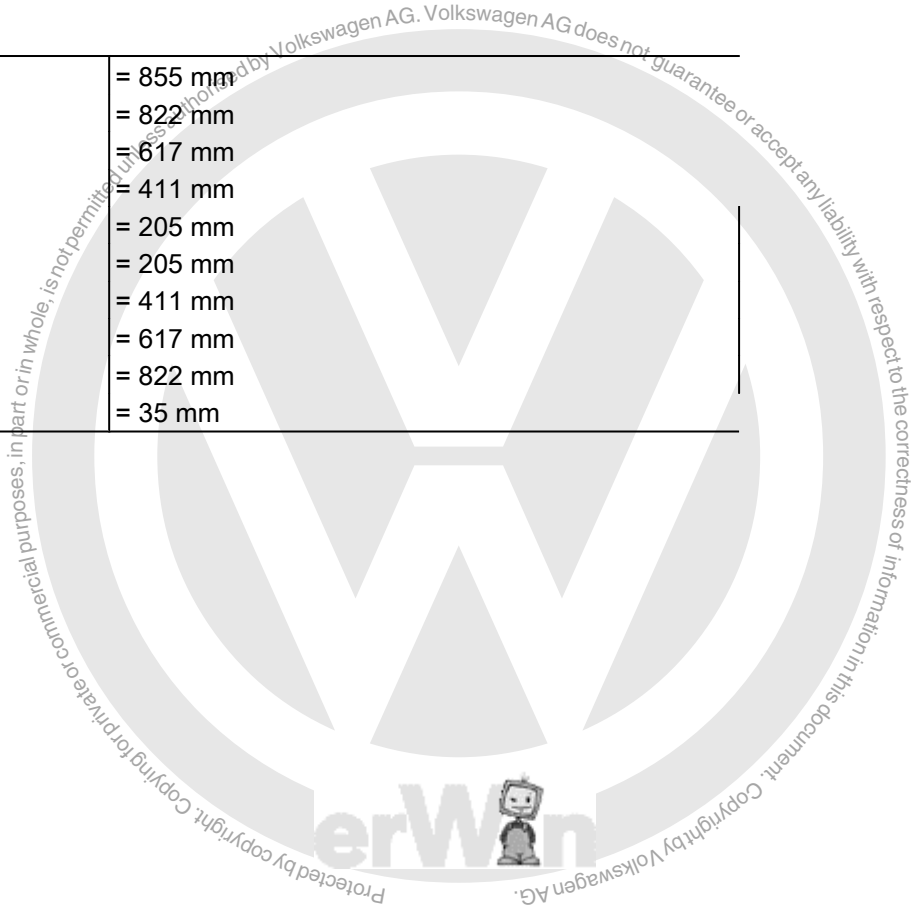

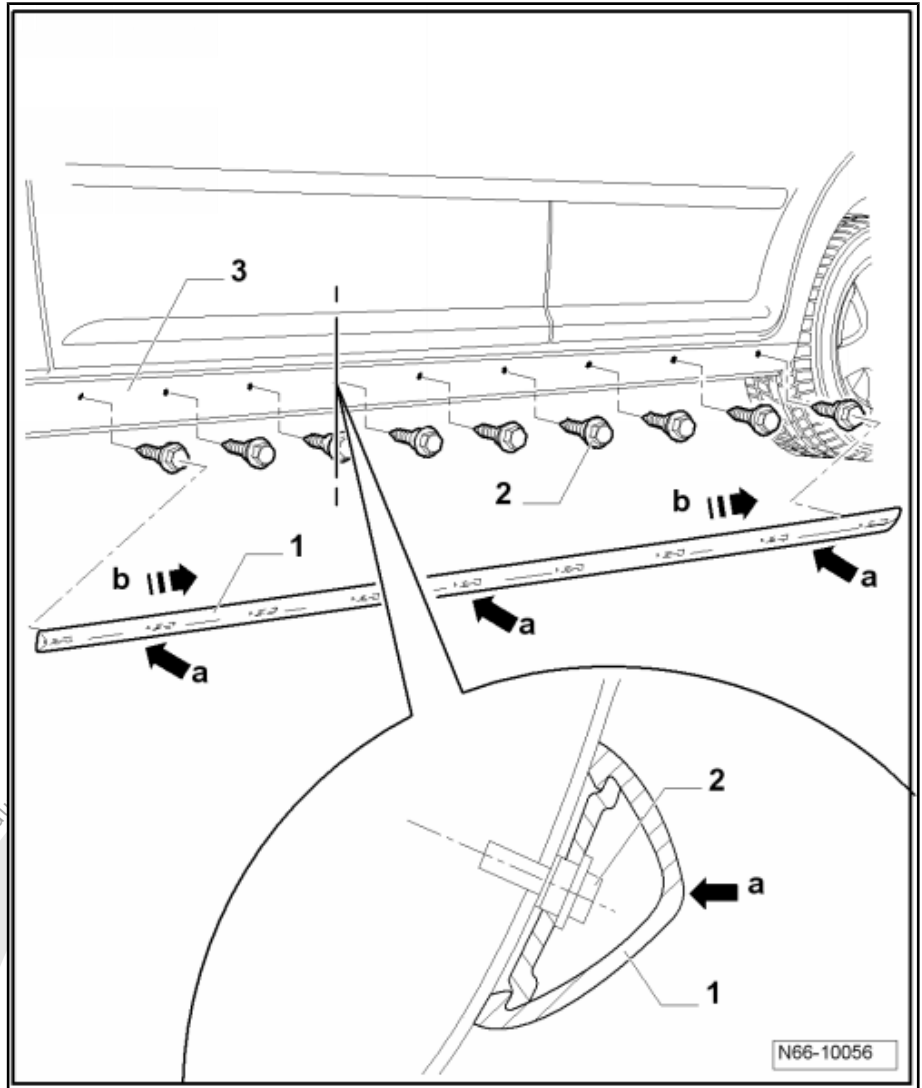

- If all securing screw holes are pre-drilled.
- Screw in self-tapping screws -2- with cordless drill/driver -VAS 5036- , using the highest speed, until the screw takes hold. Remove cordless drill/driver from head of screw immediately.
- Tighten screws using lowest torque setting (so that screws are not overtightened).
- Position openings on back of stone-chip protection trim -1- evenly -arrow a- over all securing screws -2- until stone-chip protection trim contacts side member -3-.

Use a second mechanic to ensure that all securing screws remain in openings when sliding stone-chip protection trim.

- Slide stone-chip protection trim forcibly to rear -arrow b- to stop.



4.7 Assembly overview - side member extension for GTI, GTI special models and R32

1 - Side member extension

- Removing ⇒ [page 251](#)
- Installing ⇒ [page 252](#)

2 - Bolt

- Side member extension to bracket
- Qty. 4
- 2 Nm

3 - Bolt

- Retaining strip to side skirts
- Qty. 9
- 1.2 Nm
- Installing ⇒ [page 254](#)

4 - Retaining strip

- Removing ⇒ [page 253](#)
- Installing ⇒ [page 254](#)

5 - Sill

6 - Bracket

- Secured to underbody with spreader clip

7 - Adhesive tape

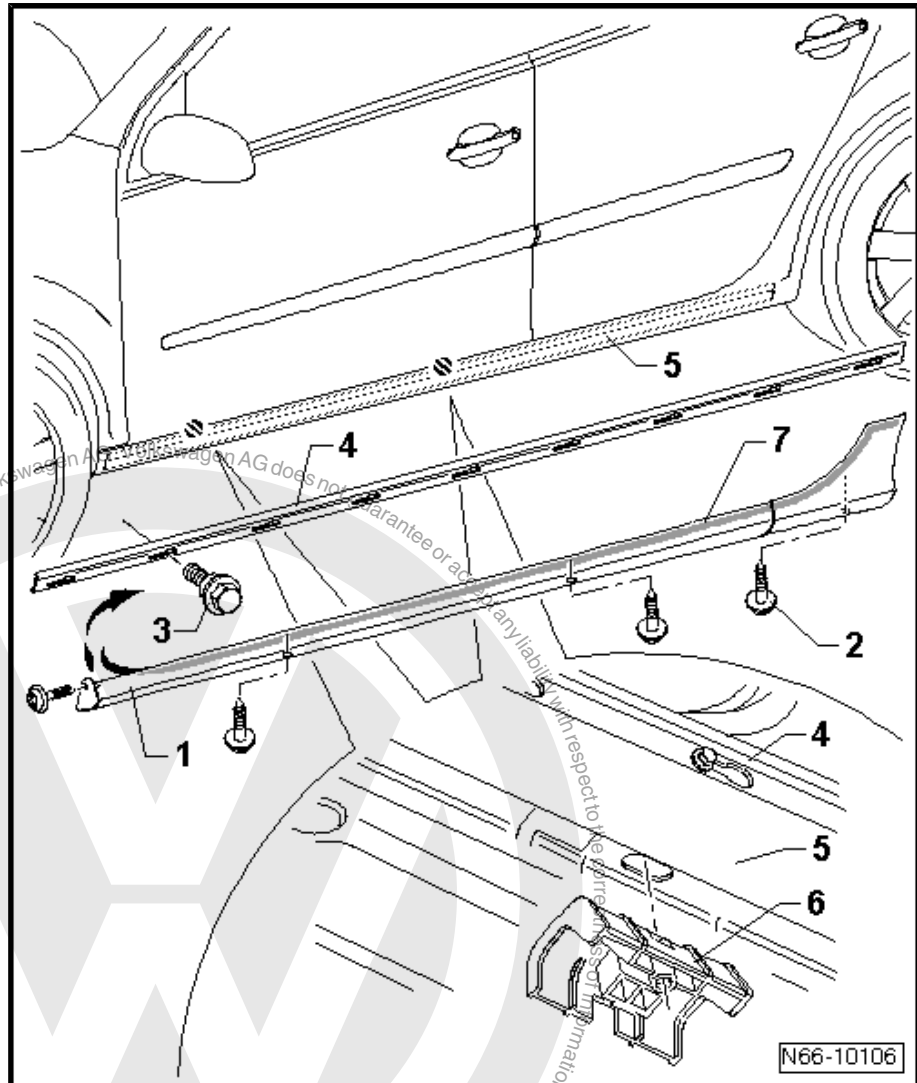



4.8 Removing and installing side member extension for GTI, GTI special models and R32

4.8.1 Removing

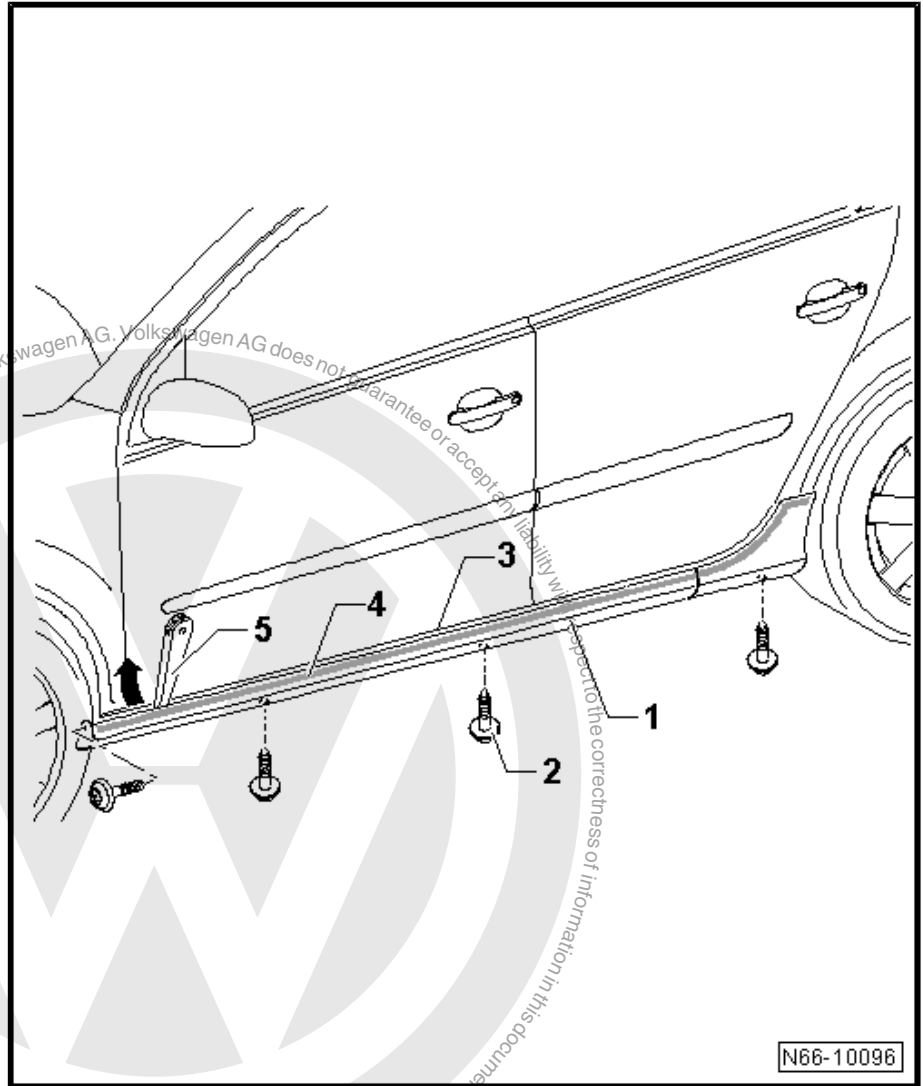

- Remove bolts -2-.
- Before removing, heat side member extension -1- in bonding surface area -4- with hot air blower -V.A.G 1416- .
- Loosen adhesive tape -4- by carefully inserting a plastic wedge -5- between side member -3- and side member extension -1-.
- As soon as adhesive tape comes loose, lift side member extension -1- up -arrow- out of retaining strip.



4.8.2 Installing



Note

- ◆ Installation is only described for the left side. The procedure for the right side is similar.
- ◆ Remove protective backing immediately before installation. Working temperature approx. 21 °C
- ◆ Curing period after side member extensions are attached is about 4 hours at a room temperature of about 21 °C.
- ◆ Adhesive remover -D 002000 10- and cleaning solution -D 009 401 04- must be used exclusively.
- ◆ Bonding surfaces must be free of dust and grease.
- ◆ The side member extensions must be bonded in place immediately after being cleaned.

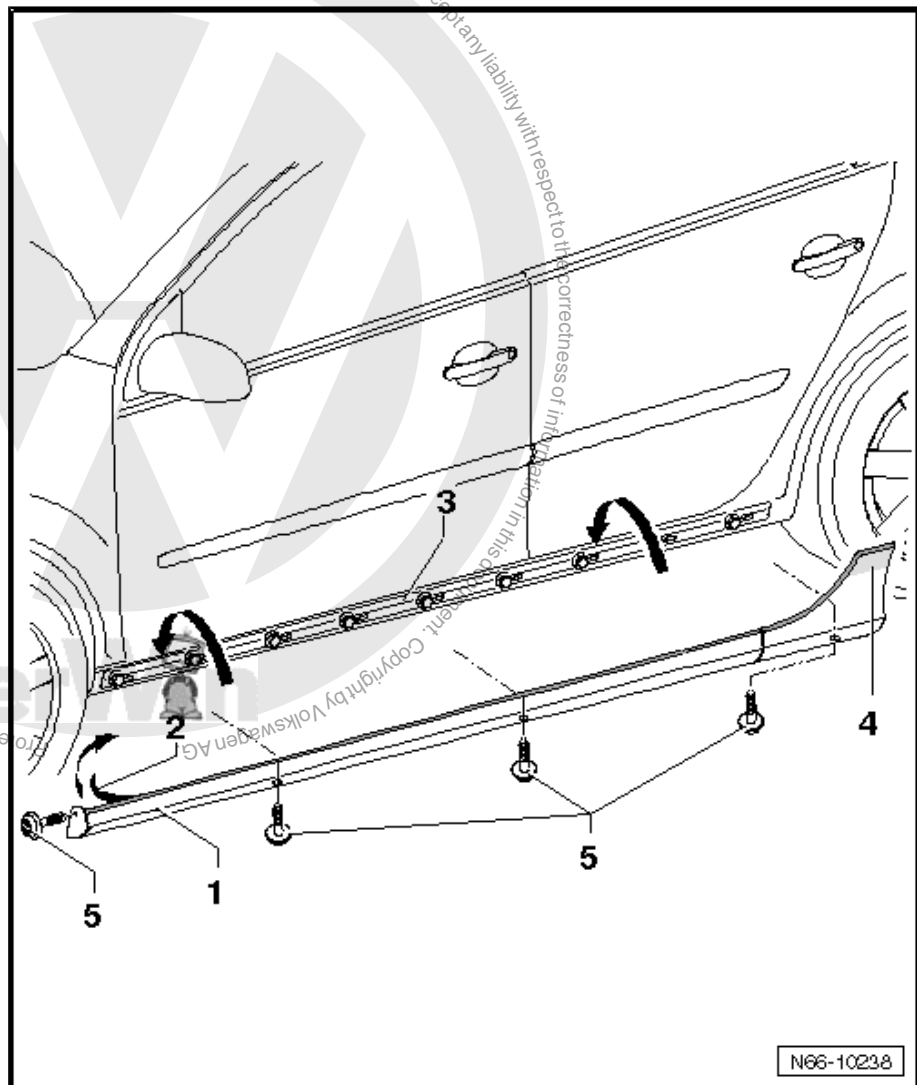

- Retaining strip is installed ⇒ [page 253](#) .
- Immediately before bonding side member extension, clean bonding surfaces thoroughly with adhesive remover -D 002000 10- and cleaning solution -D 009 401 04- .



- Position side member extension -1- from above -arrows- evenly into retaining strip -3- and press side member extension into retaining strip until the two parts engage.
- Now pull protective films -2- on side member extension -1- off upwards and backwards.
- Only now remove film -4- and press side member extension -1- on forcefully in bonding area.
- Tighten bolts -5-, beginning with front bolt on wing.

4.9 Retaining strip for side member extension

4.9.1 Removing

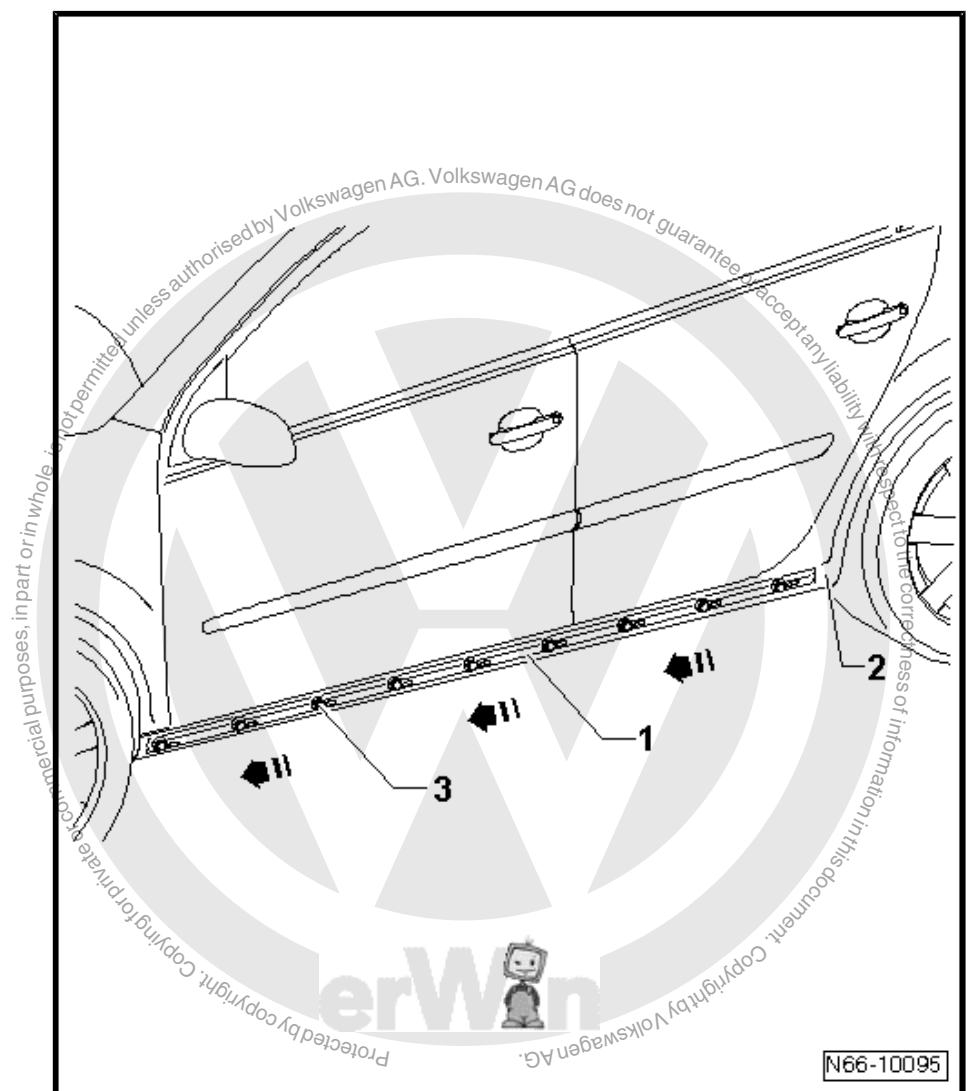

- Side member extension removed => [page 251](#)
- Push retaining strip -1- in direction of travel -arrows- from fastening bolts -3- and remove from side skirts -2-.



4.9.2 Installing



Note

- ◆ *The securing screws for the retaining strip are corrosion-resistant. No further secondary treatment is required.*
- ◆ *If a screw is overtightened, it is essential to replace it with a "black" oversize screw.*

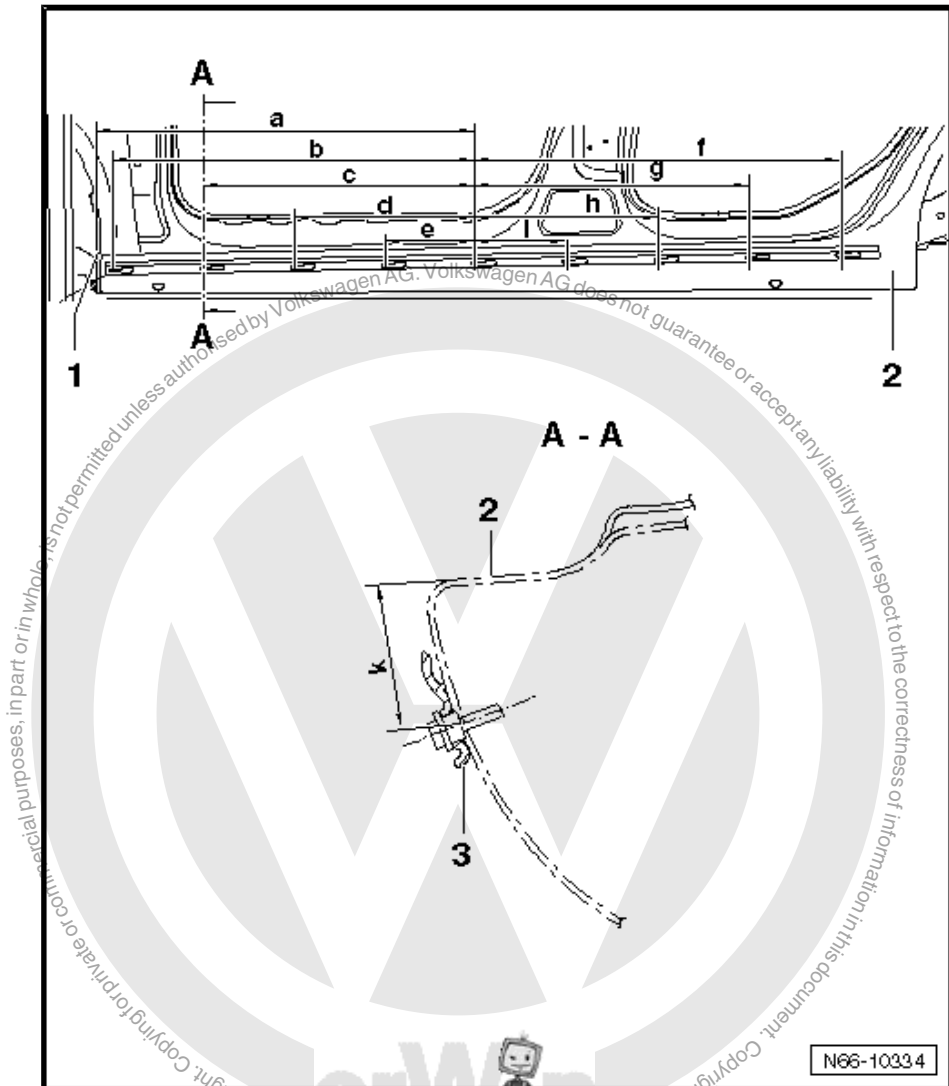

- There are no pre-drilled holes for the securing screws.
- Measure holes according to the table below.
- Mark holes for securing screws with centre punch.
- Drill out holes with a 1.5 mm drill bit.



i Note

- ◆ Dimension -a- is measured including wheel housing liner -2-. The other dimensions -b through i- are always measured from the centres of the holes.
- ◆ Dimension -k- can only be measured in rear area on 4-door vehicles.
- ◆ For two-door vehicles, determine dimension -k- in height to the front holes.

The table follows.

Dimension -a-	= 855 mm
Dimension -b-	= 822 mm
Dimension -c-	= 617 mm
Dimension -d-	= 411 mm
Dimension -e-	= 205 mm
Dimension -f-	= 205 mm
Dimension -g-	= 411 mm
Dimension -h-	= 617 mm
Dimension -i-	= 822 mm
Dimension -k-	= 37 mm

That was the table.

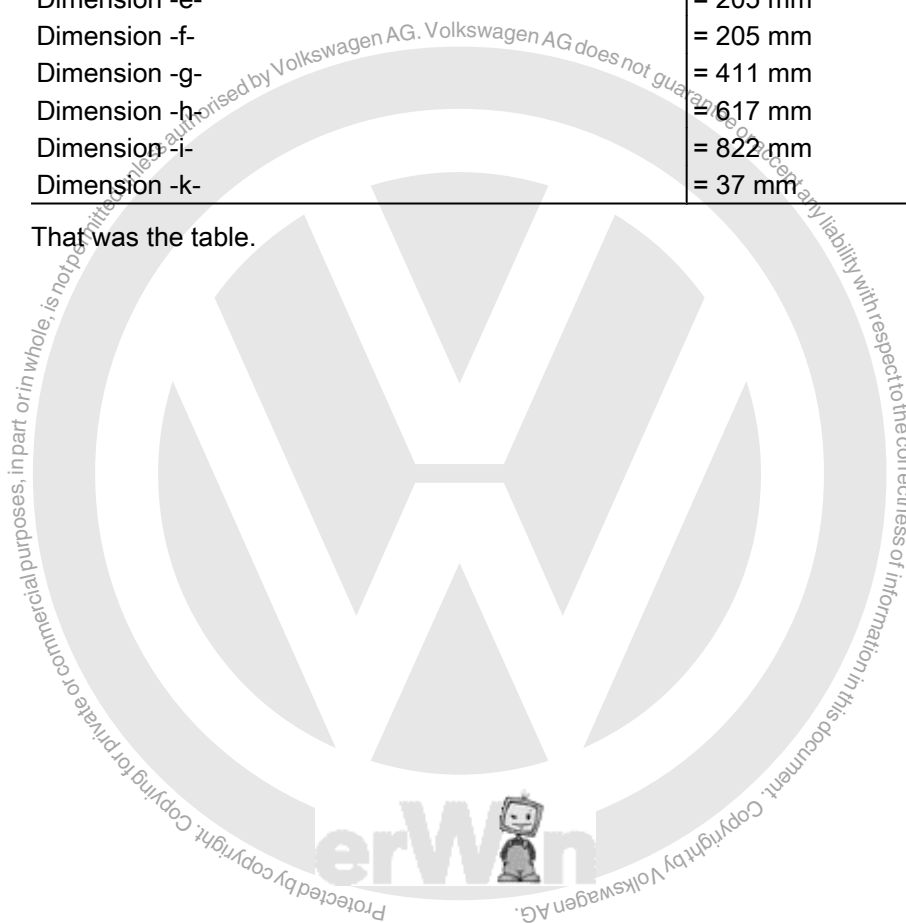

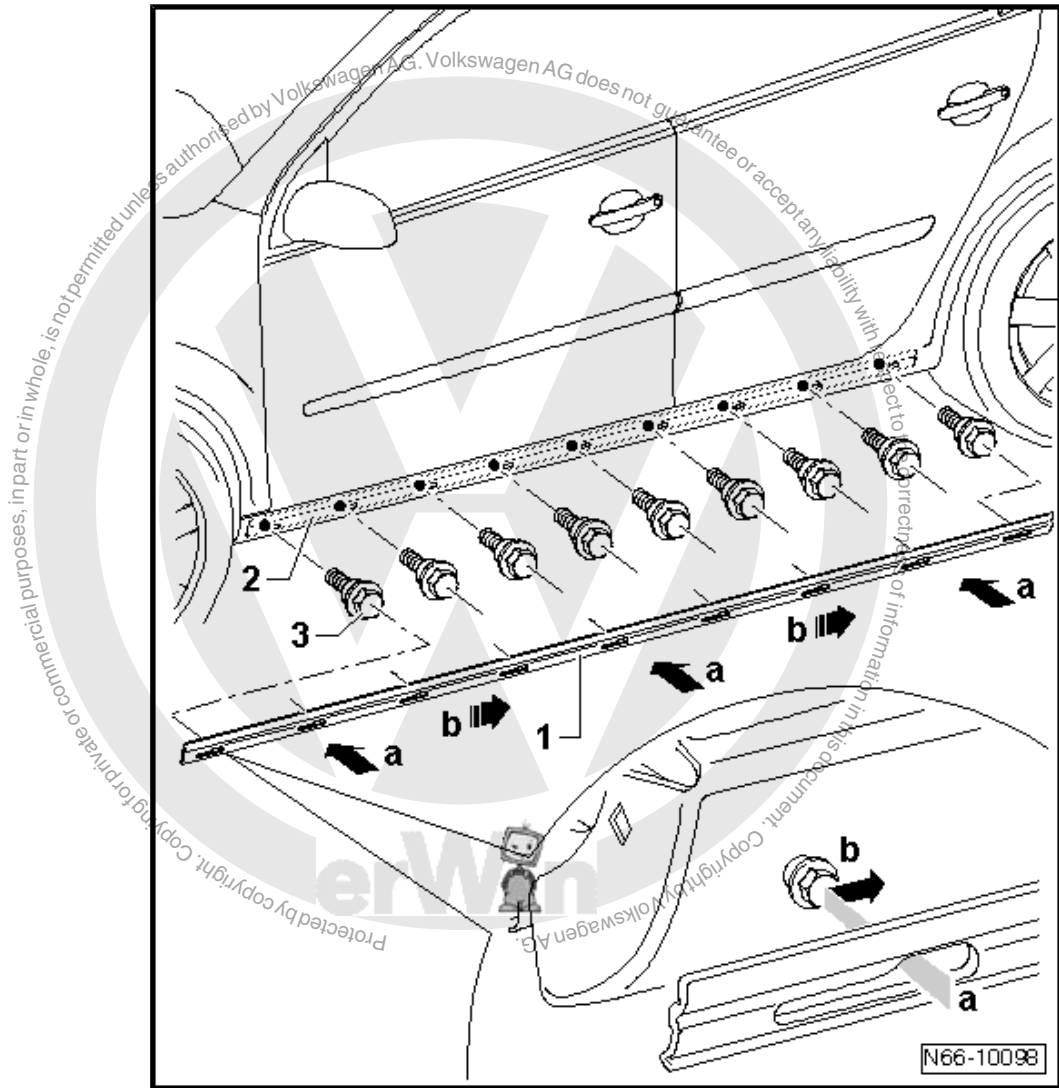

- If all securing bolt holes are pre-drilled => [page 254](#) .
 - Screw in self-tapping screws -3- with cordless drill/driver -VAS 5036- , using the highest speed, until the screw takes hold. Remove cordless drill/driver from head of screw immediately.
 - Tighten screws using lowest torque setting (so that screws are not overtightened).
 - Position openings on back of retaining strip -1- evenly -arrows a- over all securing bolts -2- until retaining strip contacts side skirts -2-.
- So that all securing bolts remain in the apertures when sliding on, position retaining strip with a second mechanic.
- Slide retaining strip to rear -arrow b- on to stop.



5 Roof edge spoiler

5.1 Tools

Special tools and workshop equipment required

- ◆ Removal kit for flush bonded windows - V.A.G 1474 A-
- ◆ Suction lifter -V.A.G 1344-
- ◆ Cutting tool -V.A.G 1351-
- ◆ Windscreen removal kit - V.A.G 1755-
- ◆ Hand-cartridge gun - V.A.G 1628-
- ◆ Cartridge heater - V.A.G 1939-

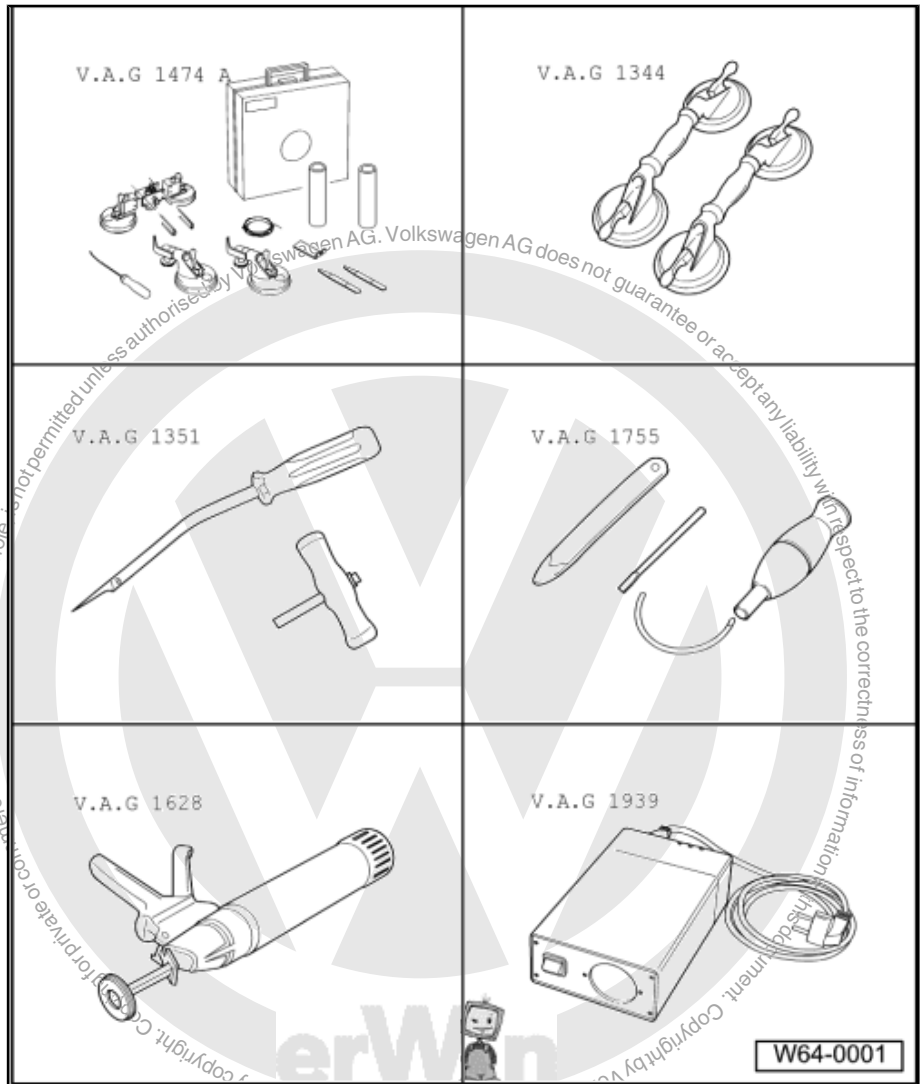

5.2 Materials

- | | |
|----------------------|-----------------|
| ◆ 1K window adhesive | -DH 009 100 03- |
| ◆ Activator | -D 181 801 A1- |
| ◆ Primer | -D 009 200 02- |
| ◆ Cleaning solution | -D 009 401 04- |
| ◆ Primer applicator | -D 009 500 25- |
| ◆ Adhesive remover | -D 002 000 10- |
| ◆ Cutting cord | -357 853 999 A- |



Note

Observe instructions for use on the information sheet provided by the manufacturer.

Use double cartridge gun -VAS 5237- to apply two-component adhesives.

Heat one-component window adhesive according to manufacturer's instructions, using cartridge heater V.A.G 1939A- .

Small cartridge, 110 ml, for sealing and/or when a 400 ml cartridge alone is not sufficient.

5.3 Assembly overview - roof spoiler for GTI, GTI special models and R32

1 - Rear lid

2 - Primer area

- For adhesive bead on retaining strip
- Position of primer area must be transferred from indentation for adhesive bead in retaining strip

3 - Primer area

- For adhesive bead on roof spoiler
- Position of primer area must be transferred from roof spoiler

4 - Retaining strip

- With indentation for adhesive bead, bead cross section: width = 6 mm; height = 10 mm
- Removing ⇒ [page 262](#)
- Installing ⇒ [page 263](#)
- Installation instructions ⇒ [page 264](#)

5 - Foam strip

- Self-adhesive
- Before installing roof spoiler, check foam strip for damage and renew if necessary

6 - Adhesive tape

- Two strips for securing roof spoiler at sides

7 - Bonding surface

- Marked in inner part of roof spoiler

8 - Roof edge spoiler

- Material PC/PET
- Removing ⇒ [page 259](#)
- Installing ⇒ [page 261](#)

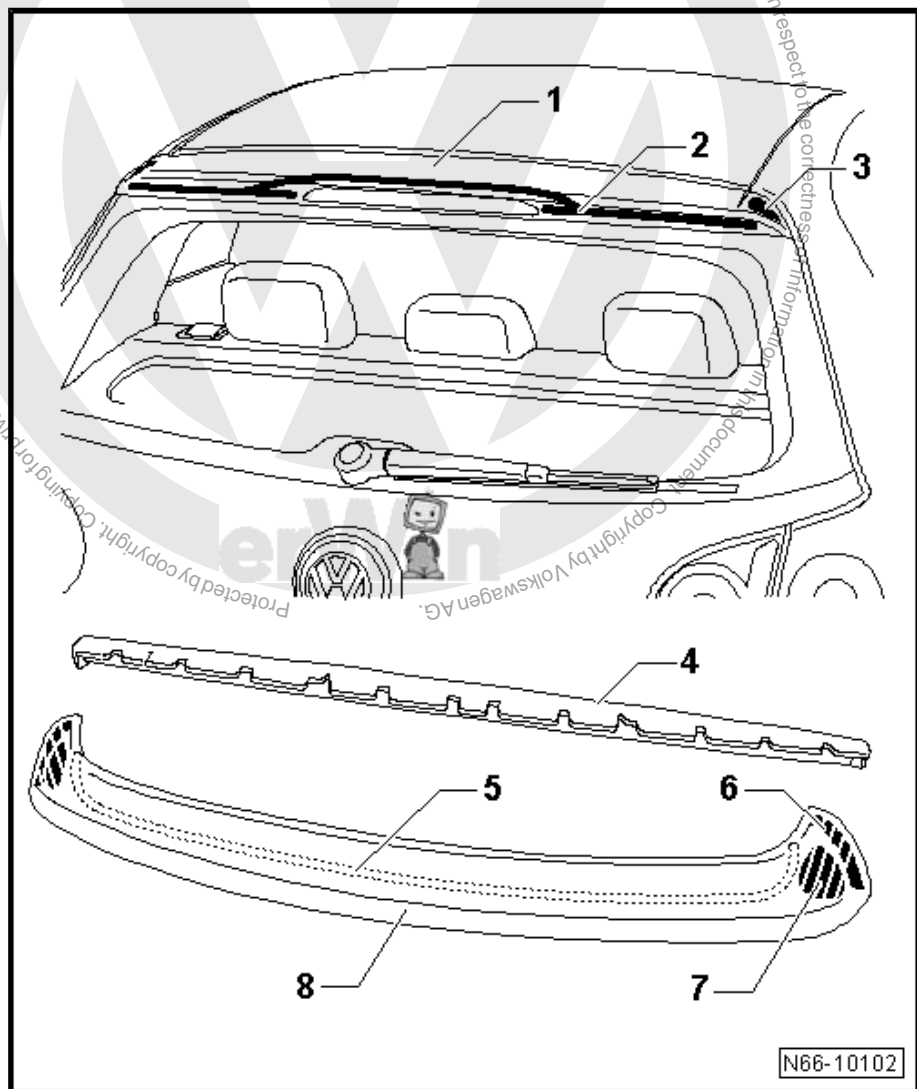



- Installation instructions ⇒ [page 264](#)

5.4 Removing and installing roof spoiler for GTI, GTI special models and R32

5.4.1 Removing



WARNING

Clean all surrounding parts before beginning work and mask them with tape.

Do not use cutting wire to remove the roof spoiler.

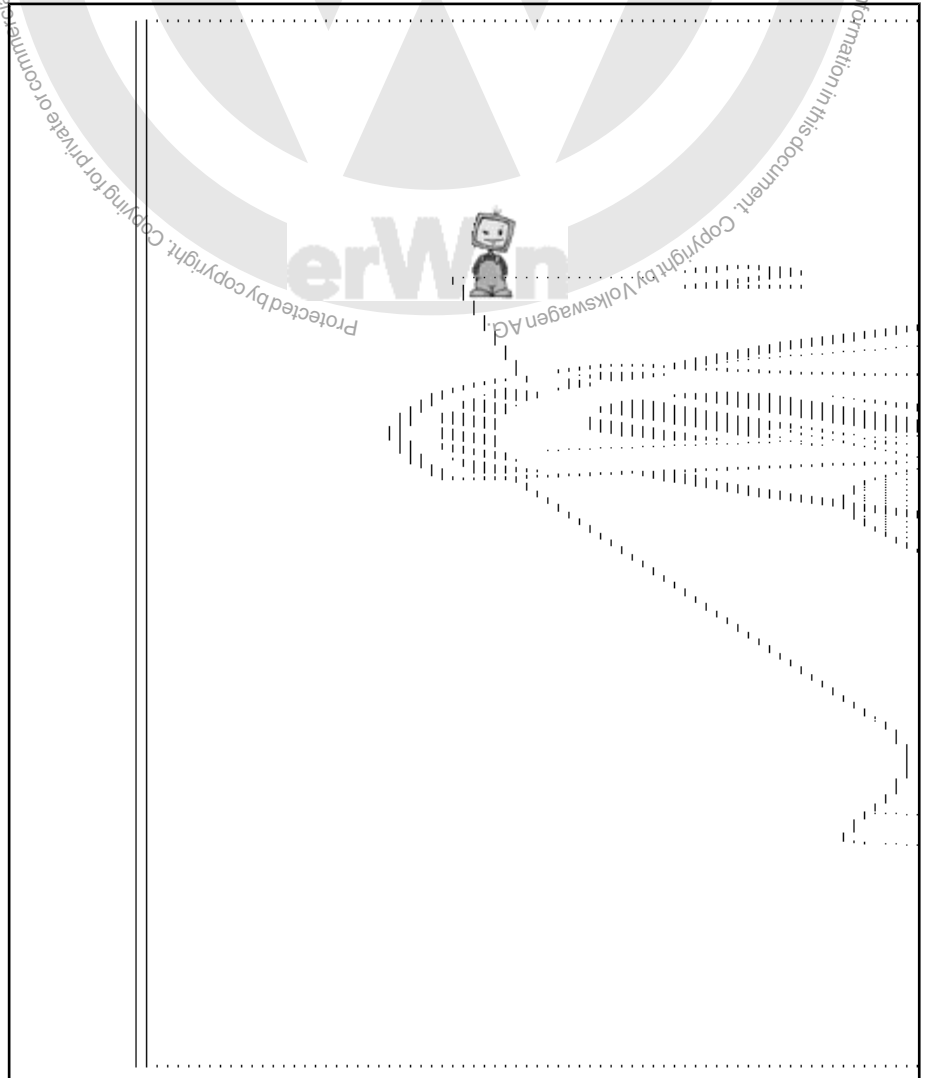

- Thread cutting thread -6- in between rear lid -1- and roof spoiler -4-.
- Using both handles -5- in "sawing" movements, separate adhesive tape -2- and adhesive bead -3- on one side.



- Repeat adhesive tape and adhesive bead separation on the other side.



Note

The middle hook is present only on vehicles from 02.05.

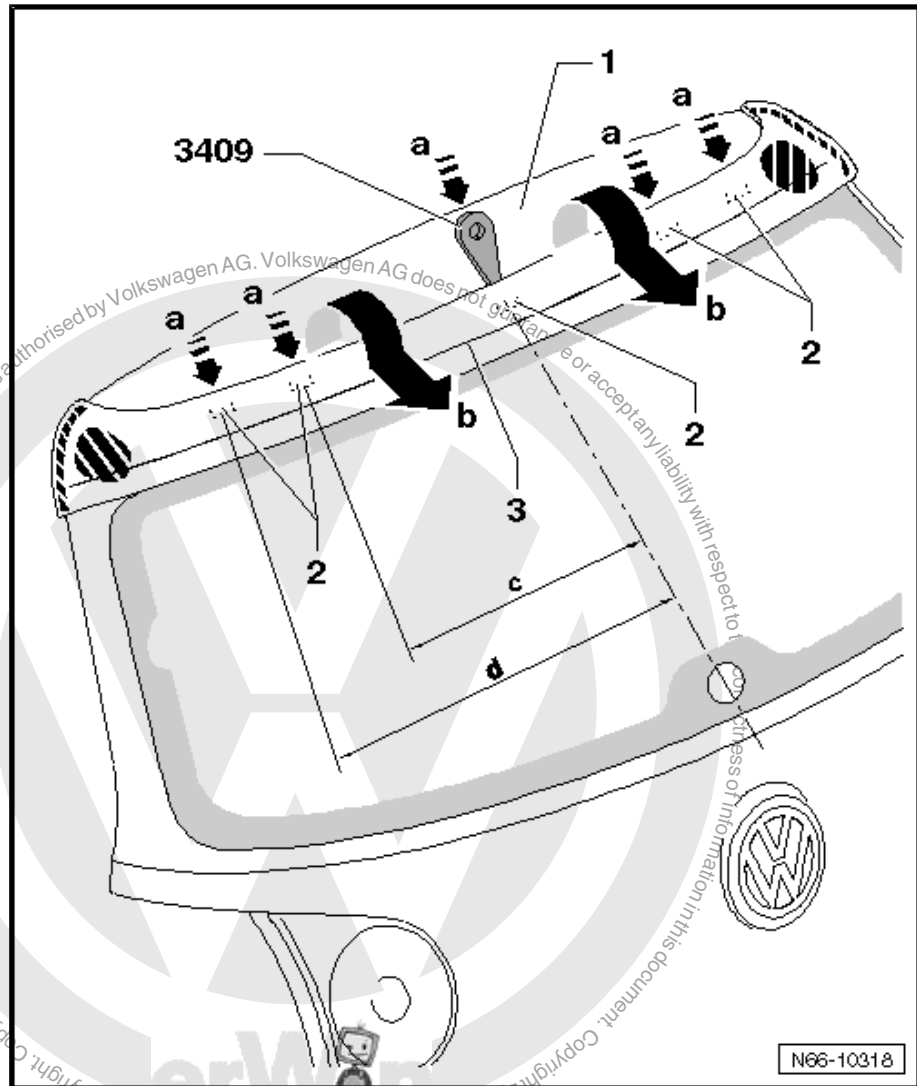

- Push several wedges -3409- between rear lid -1- and roof spoiler -arrows a- until all hooks -2- are released. A clear click can be heard.

The hooks on the sides are -dimension c- = 260 mm and -dimension d- = 400 mm from the centre.

- Reach between roof spoiler and rear lid, press roof spoiler -3- forcefully against rear lid and release roof spoiler upwards -arrows b- from fasteners -4- of retaining strip.



5.4.2 Installing



Note

Check all hooks for damage and renew the roof spoiler if necessary.

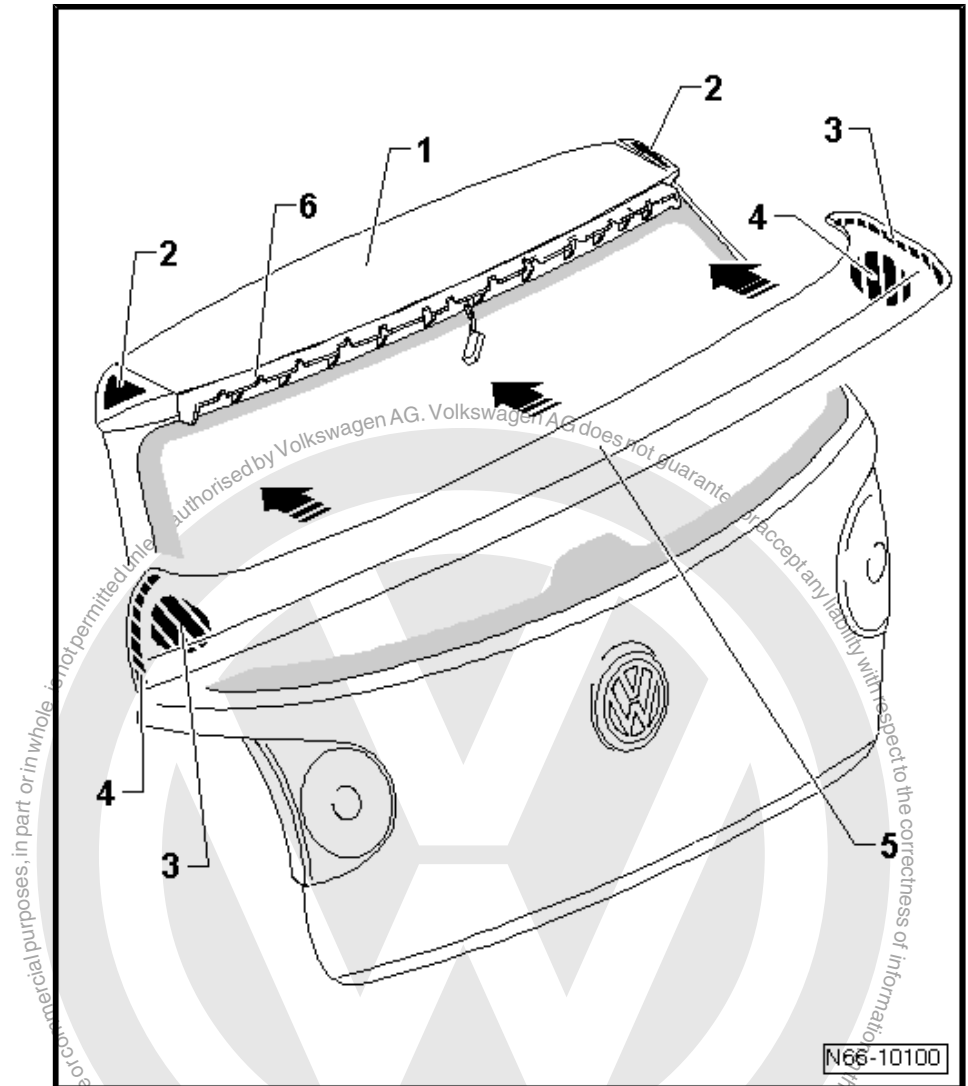

- Retaining strip -6- installed ⇒ [page 263](#) .
- Brake light in roof spoiler is installed ⇒ Electrical system; Rep. Gr. 94 ; Lights, bulbs, switches - exterior; Auxiliary brake lights; High level brake light bulb - M 25 - removed and installed, Golf GTI .
- Areas on roof spoiler -3- and rear lid -2- have been primed.
 - Apply adhesive bead onto primed area -3- on roof spoiler.
 - Place roof spoiler -5- onto retaining strip -6-.
 - Align roof spoiler -5- with rear lid -1- and press roof spoiler into retaining strip detents.
 - With new roof spoilers, now pull protective film off from adhesive tape -4- and firmly press roof spoiler onto rear lid.



- If roof spoilers are re-used, secure corners of roof spoiler to rear lid with commercially available adhesive tape.

5.5 Retaining strip

5.5.1 Removing retaining strip

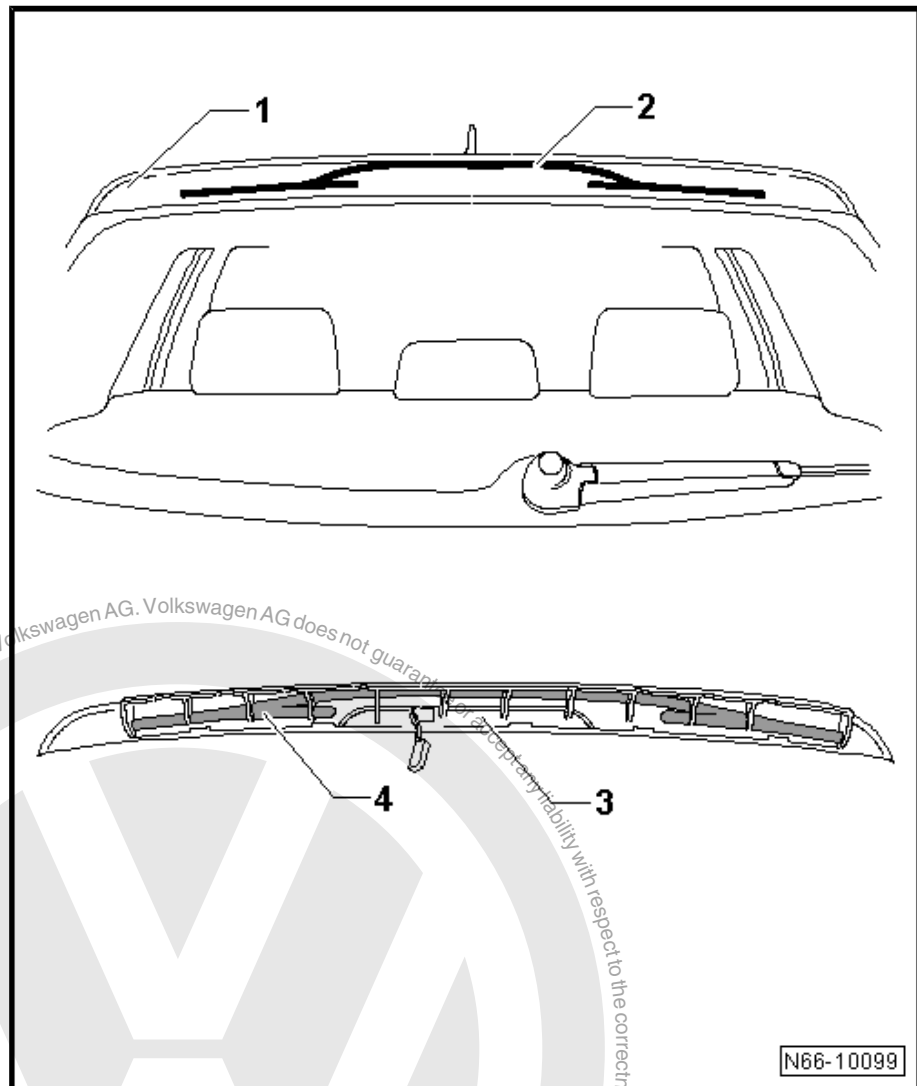

- Roof spoiler is removed ⇒ [page 259](#) .
- Separate adhesive bead -2- using cutting thread and handles.



5.5.2 Installing retaining strip

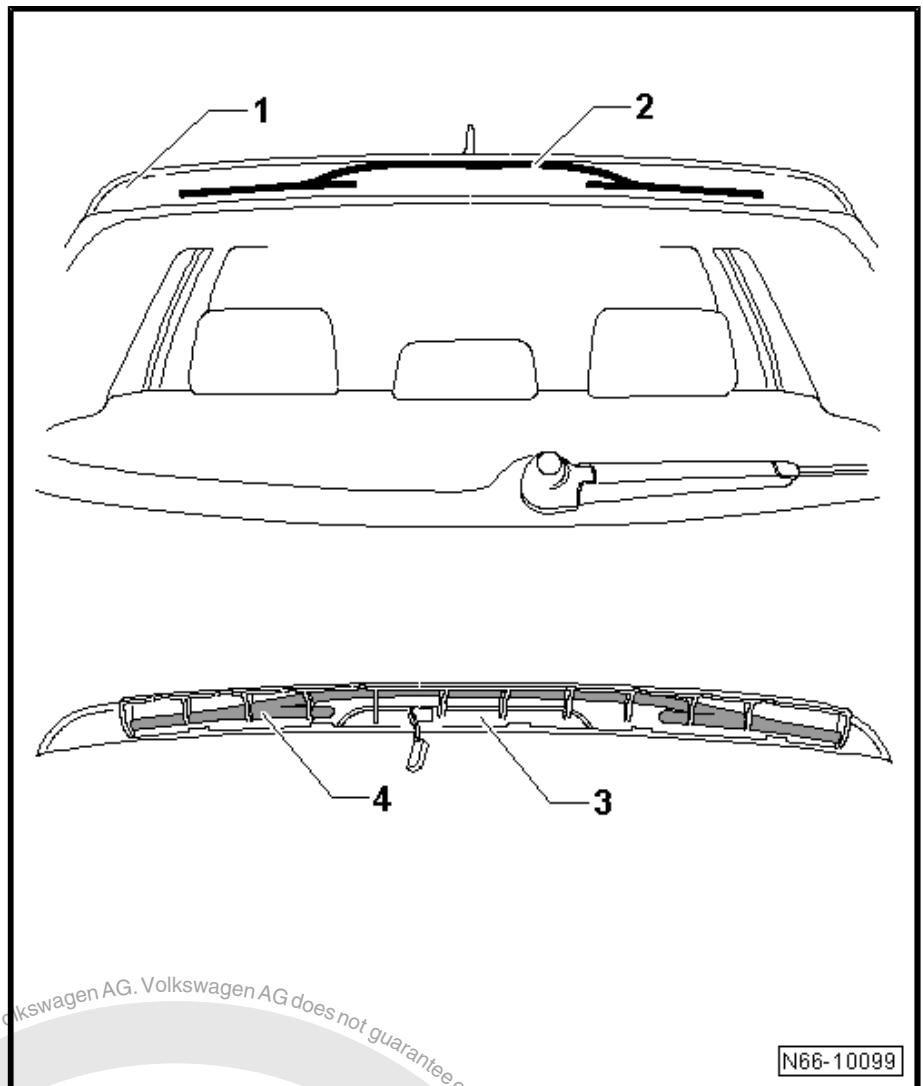

- Bonding areas -2- on retaining strip and rear lid have been primed.
- Apply adhesive bead to retaining strip recess.
- Align retaining strip -4- with original cut-out for brake light -3-.
- Secure retaining strip with commercially available adhesive tape.

5.6 Preparing body kit component for bonding



Note

Remaining material serves as adhesion base for newly applied adhesive sealing compound. Keep dirt and grease off of bonding surfaces.

Exception: if bonding is not performed immediately after cutting back, the remaining residual material must be activated with activator -D 181 801 A1.



WARNING

Activator must not have contact with paint or the paintwork will be damaged.



Note

If the body kit part has been repaired or partially renewed, the area concerned must be cleaned and primed again after painting.

5.7 Installation instructions

The surfaces to be primed for the body kit parts should be completely clean.

- Adhesive residue should be removed using adhesive remover -D 002 000 10- .
- Soak cloth in silicon remover -LSE 020 100 A3- .
- Clean area of application for adhesive bead twice thoroughly using cloth applied with solution and allow to dry.
- Now apply primer using applicator -D 009 500 25- equally in one stroke.
- ◆ Drying time approx. 10 minutes
- Adhesive material should be applied to the primed areas of the body kit parts.



WARNING

Body kit parts should be installed within 10 minutes, or bonding properties of adhesive will be impaired.

- ◆ Gap dimensions should be kept to an absolute minimum, up to approx. 1 mm.
- ◆ Use adhesive tape to secure body kit part in position while curing.

5.8 Minimum curing period

The minimum curing time for newly bonded attaching parts is 3 hours.

The minimum curing time is the period between bonding the accessory parts to installation. During this time, the vehicle must stand on a level surface at room temperature (at least 15 °C).



WARNING

Vehicle is safe to use only after the minimum curing period is completed.

5.9 Touching up paint damage

Paint structure must be restored according to specifications in the "Paint" workshop manual.



5.10 Cleaning off excess adhesive sealing material

- Use of adhesive remover -D 002 000 10- as a cleaning solution is recommended. Observe the appropriate safety precautions when performing this work.
- First clean painted surface as much as possible using a dry cloth. Remove residue using adhesive remover -D 002 000 10- .





6 Protective backing

6.1 Attachment notes for protective backing



Note

- ◆ *Before removal, heat the scuff protection film with a hot air blower -V.A.G 1416-.*
- ◆ *Use only adhesive remover -D 002 000 10- to remove residual adhesive.*
- ◆ *Ensure that the adhesive surfaces are free of dust and grease.*
- ◆ *Bond scuff protection film immediately after cleaning.*
- ◆ *Pull protective film off only directly prior to installation.*
- ◆ *The working temperature is approx. 21 °C.*





6.2 Renewing scuff protection film



Renewing scuff protection films is described only for the left side. The right side is similar.

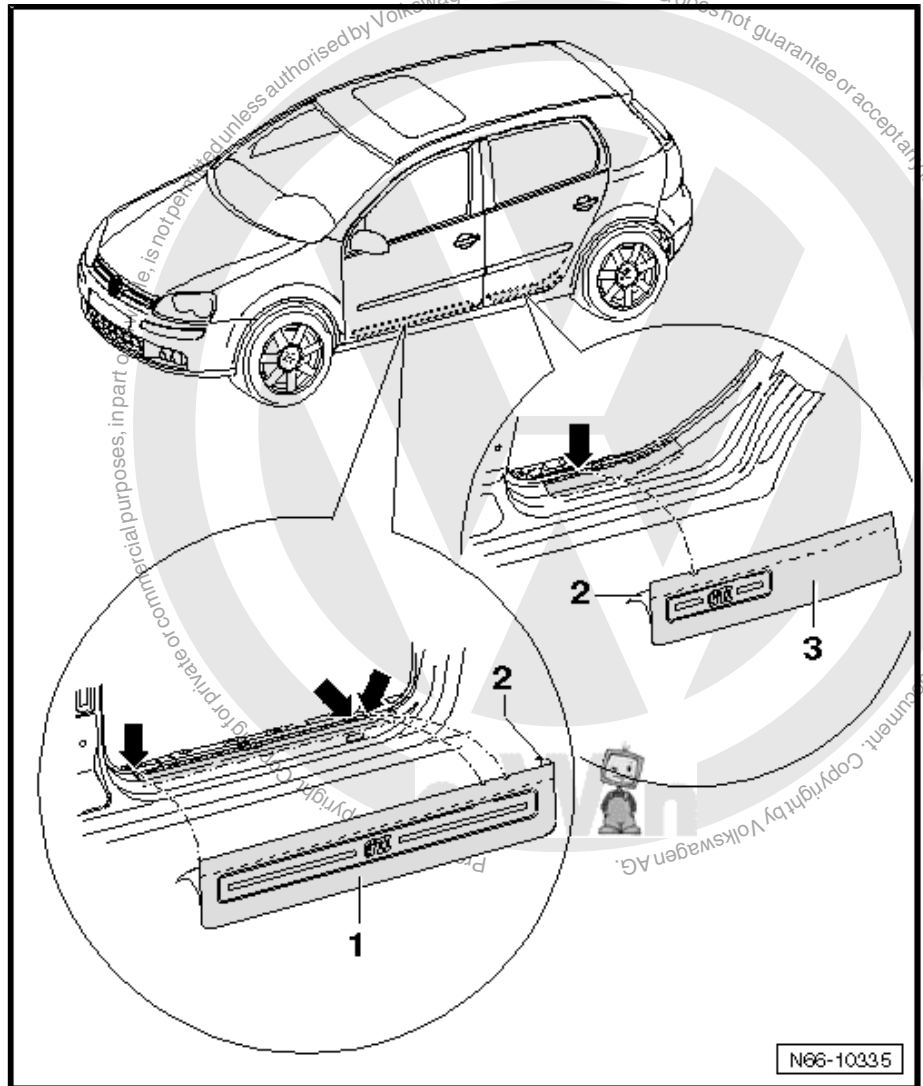

Removing

- Removing inner seal for front door in area of side member => [page 75](#) or inner seal for rear door => [page 114](#)
- Heat scuff protection film at the front -1- or at the rear -3- using a hot air blower -V.A.G 1416- and pull scuff protection film from sill.

Installing

- Clean installation area with adhesive remover -D 002 00 10- .
- Pull off protective film -2-.
- Position scuff protection film at the front -1- or at the rear -3- on the references points -arrows- and press it smooth using a plastic blade wrapped in a soft paper towel.



7 Lettering

7.1 Tools

Special tools and workshop equipment required

- ◆ Hot air blower -V.A.G 1416-

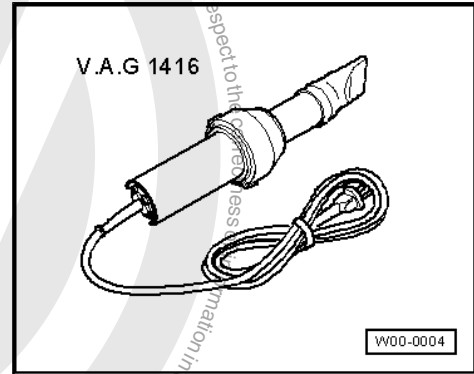

7.2 Installation instructions for lettering and emblems



Note

- ◆ *Before removal, heat the lettering or the emblem with a hot air blower -V.A.G 1416- .*
- ◆ *Use only adhesive remover -D 002 000 10- to remove residual adhesive.*
- ◆ *Ensure that the adhesive surfaces are free of dust and grease.*
- ◆ *Bond lettering or emblem immediately after cleaning.*
- ◆ *Pull protective film off only directly prior to installation.*
- ◆ *The working temperature is approx. 21 °C.*

7.3 Rear lettering dimensions

1 - Dimension a = 50 mm

- From outer edge of rear lid to lettering

2 - Dimension b = 90 mm

- From lower edge of rear lid to lower edge of lettering

3 - Lettering

- Model designation

4 - Lettering

- Engine designation

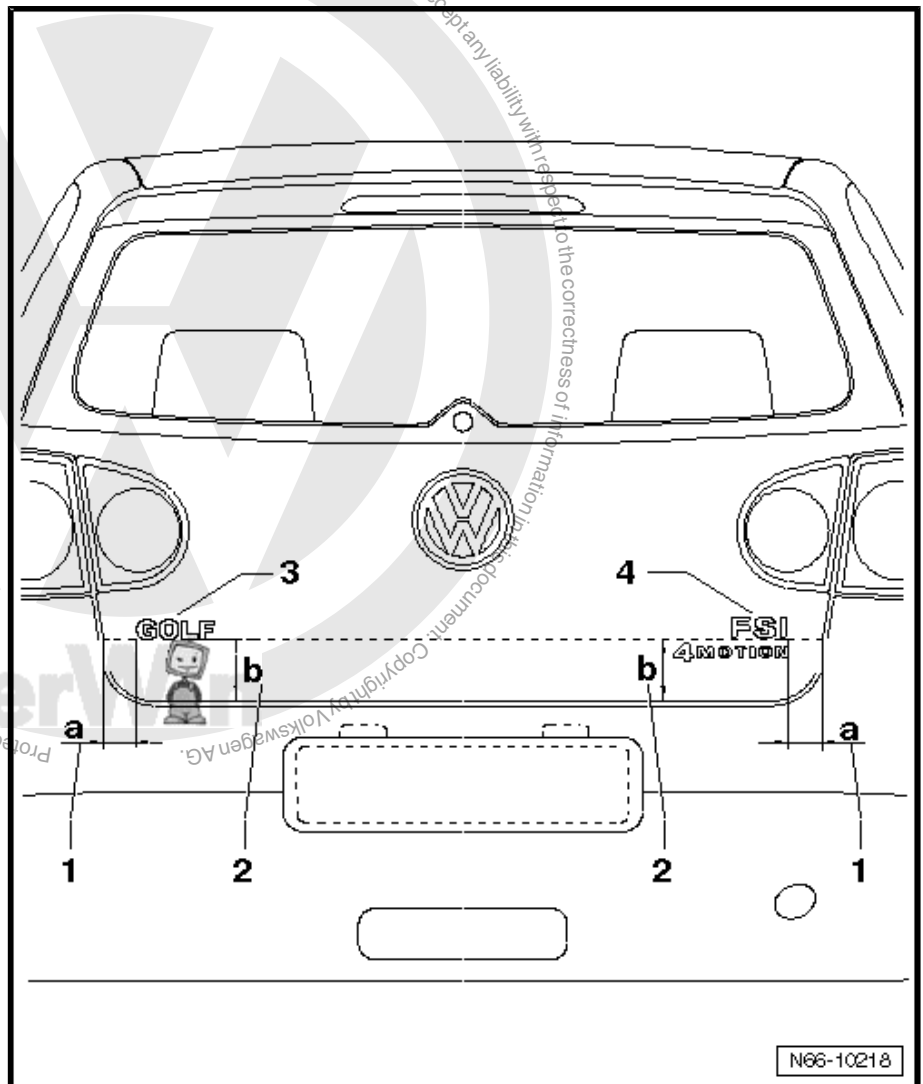



7.4 Rear lettering dimensions for GTI and R32

1 - Dimension a = 50 mm

- From outer edge of rear lid to lettering

2 - Dimension b = 90 mm

- From lower edge of rear lid to lower edge of lettering

3 - Lettering

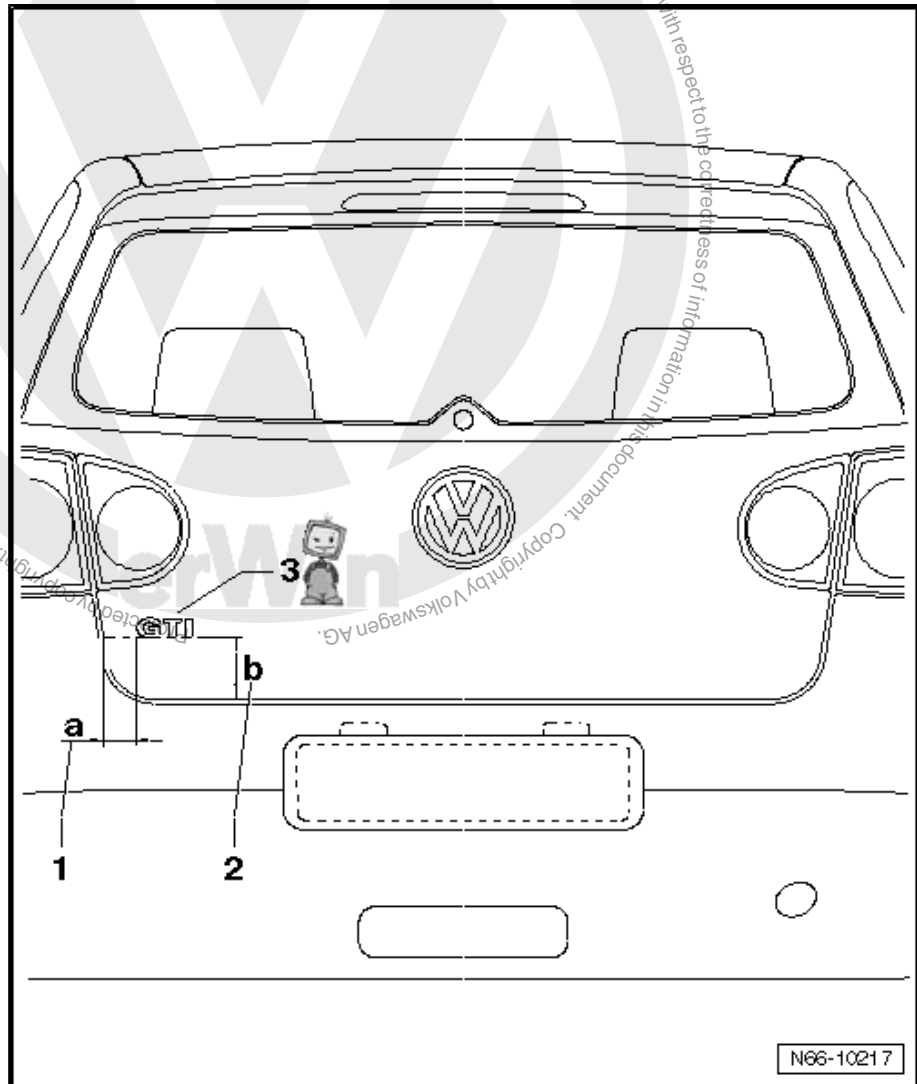



7.4.1 Rear lettering dimensions for GTI special models

- 1 - Dimension a = 50 mm
 - From outer edge of rear lid to lettering
- 2 - Dimension b = 90 mm
 - From lower edge of rear lid to lower edge of lettering
- 3 - Lettering

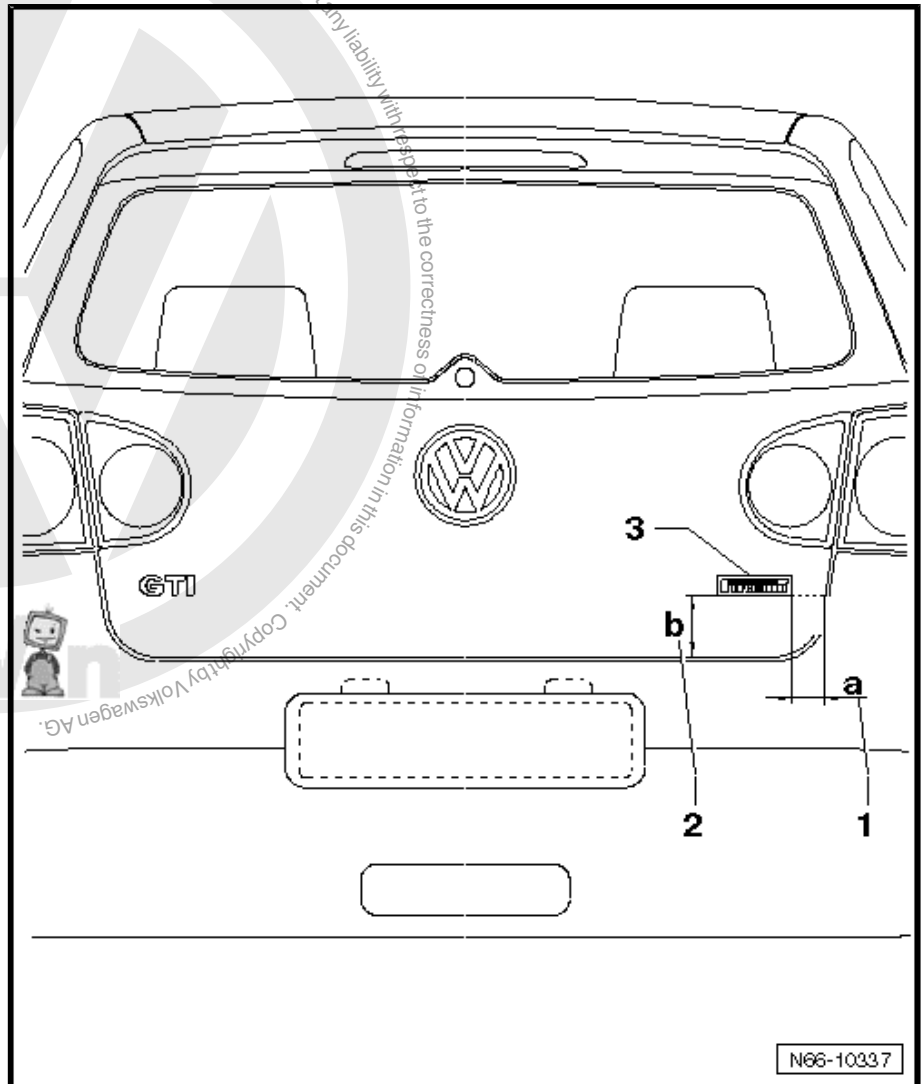



7.5 Rear lettering dimensions - USA

1 - Dimension a = 50 mm

- ❑ From outer edge of rear lid to lettering

2 - Dimension b = 90 mm

- ❑ From lower edge of rear lid to lower edge of lettering

3 - Dimension c = 15 mm

- ❑ From emblem to lettering

4 - Lettering "Rabbit"

5 - Lettering

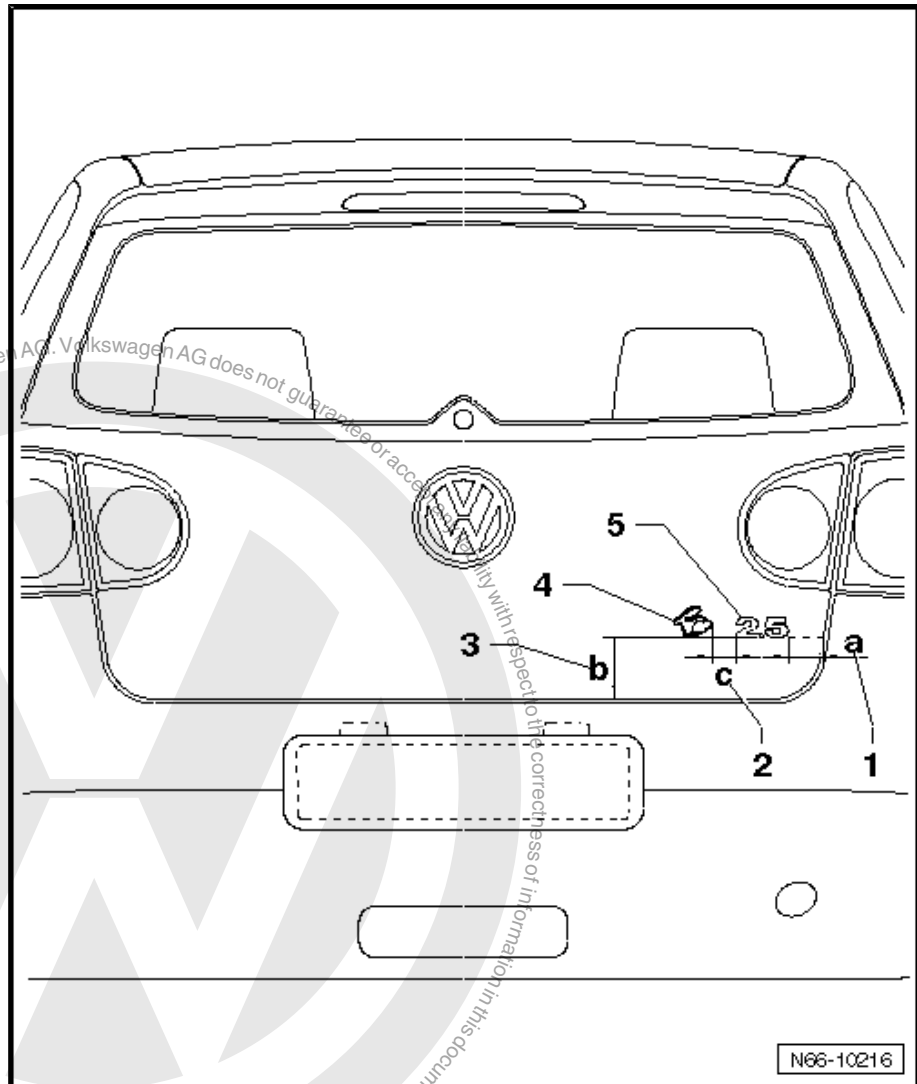

Protected by copyright. Copying for private or commercial purposes, in part or in whole, is not permitted unless authorised by Volkswagen AG. Volkswagen AG does not guarantee or accept any liability with respect to the correctness of information in this document.





7.6 Side lettering dimensions - Individual

7.6.1 Dimensions of emblem, left wing

1 - Dimension a = 551 mm

- ❑ Transfer the -dimension a - from the underside of the wing to the wing.

2 - Dimension b = 14 mm

- ❑ Transfer -dimension b- from end point of dimension a to end point of emblem.

3 - Dimension c = 70 mm

- ❑ Use -dimension c- to check distance from upper edge of emblem to the edge of wing.

4 - Dimension d = 92 mm

- ❑ Use -dimension d- to check distance from lower edge of emblem to edge of wing.

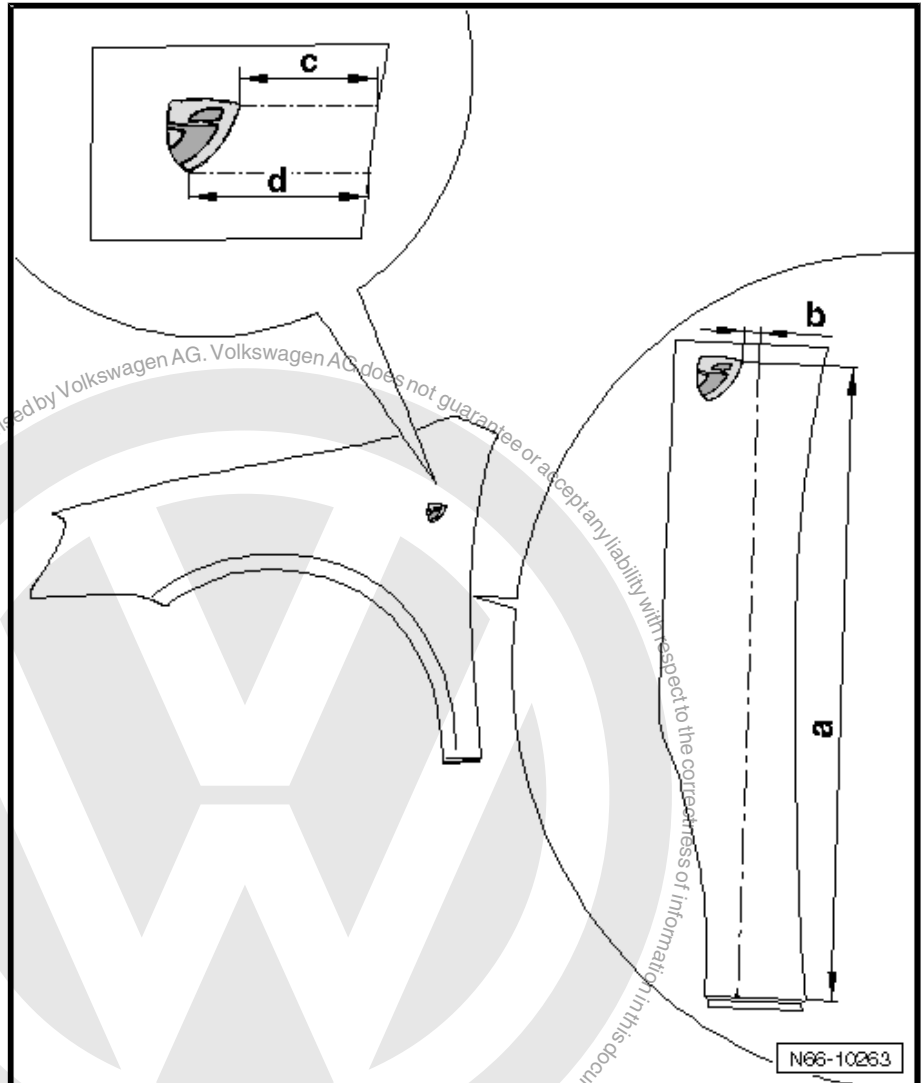



7.6.2 Dimensions of emblem, right wing

1 - Dimension a = 550 mm

- ❑ Transfer the -dimension a - from the underside of the wing to the wing.

2 - Dimension b = 30 mm

- ❑ Transfer -dimension b- from end point of -dimension a- to corner point of emblem.

3 - Dimension c = 86 mm

- ❑ Use -dimension c- to check distance from upper edge of emblem to the edge of wing.

4 - Dimension d = 92 mm

- ❑ Use -dimension d- to check distance from lower edge of emblem to edge of wing.

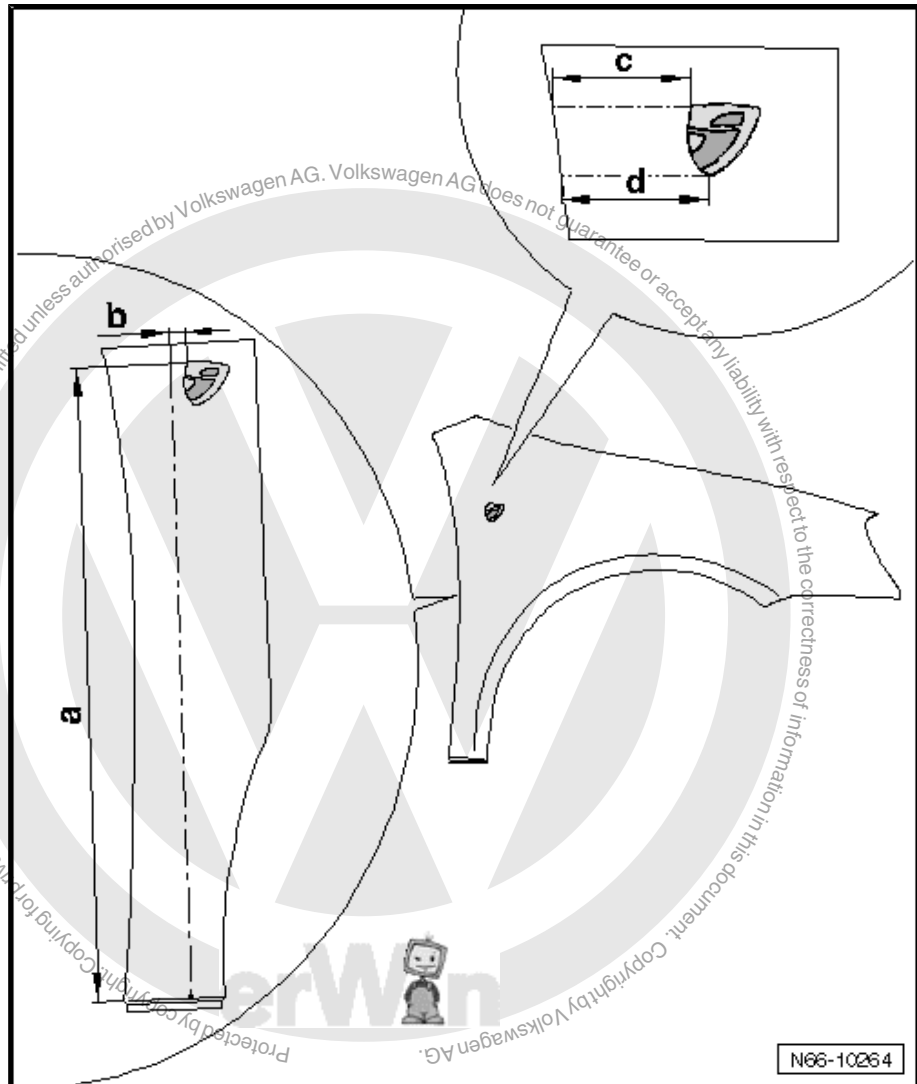



7.6.3 Dimensions of R-line emblem

i Note

- ◆ The dimensions of the R-line emblem are described only for the left side. The right side is similar.
- ◆ The dimensions -b- and -c- indicate the inclination of the logo. The logo must be bonded parallel to the lower edge of the wing.

- 1 - Dimension a = 91 mm
 - From lower edge of wing to corner point of emblem
- 2 - Dimension b = 510 mm
 - From rear lower wing corner to -dimension a-
- 3 - Dimension c = 510 mm
 - From front lower wing corner to corner point of emblem

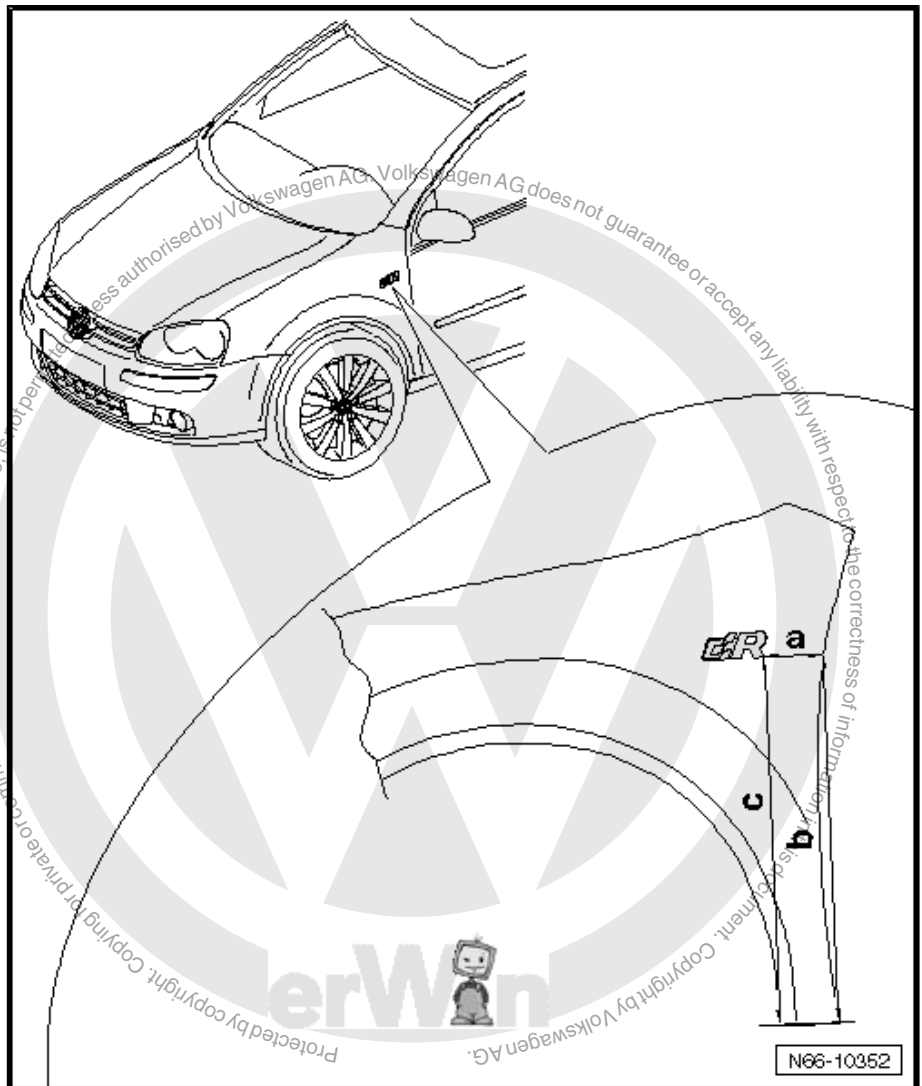



8 Vermin repellent system

Volkswagen Individual optional equipment

8.1 Assembly overview - vermin repellent system



Note

- ◆ The items 2 to 5 are also installed on the passenger side.
- ◆ The system prevents access for vermin.

1 - Protective part for vermin repellent system

- Various versions depending on engine type

2 - Bolt

- Qty. 2
- 2 Nm
- 5 x 20

3 - Upper protective part for vermin repellent system

- Material: PP (polypropylene) in brush form

4 - Front protective part for vermin repellent system

- Material: PP (polypropylene) in brush form
- With 3 speed nuts

5 - Bolt

- Qty. 3
- 2 Nm
- 5 x 16

6 - Noise insulation

- Material: PP (polypropylene)
- Removing and installing
[⇒ page 13](#)

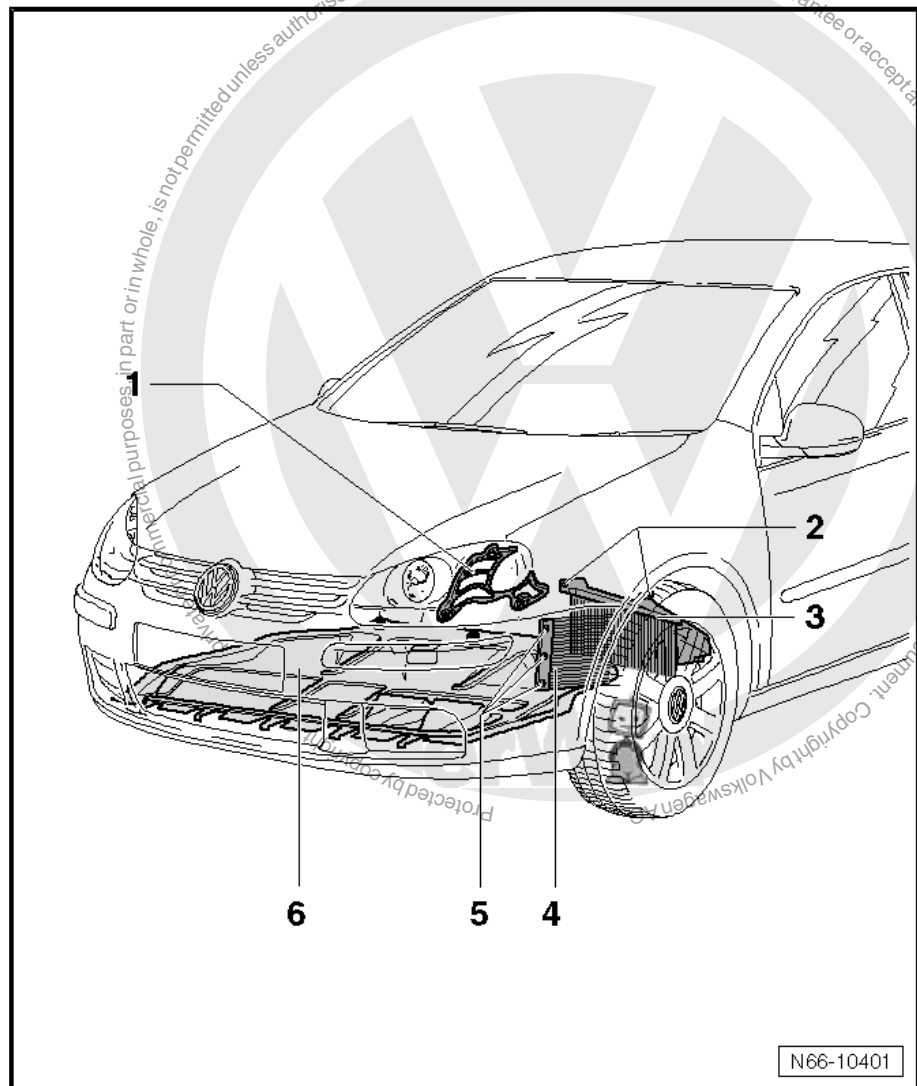

8.1.1 Removing



Note

The suspension strut is not shown in the illustration for reasons of clarity.

- Unscrew bolts -1-.
- Remove parts from vehicle.

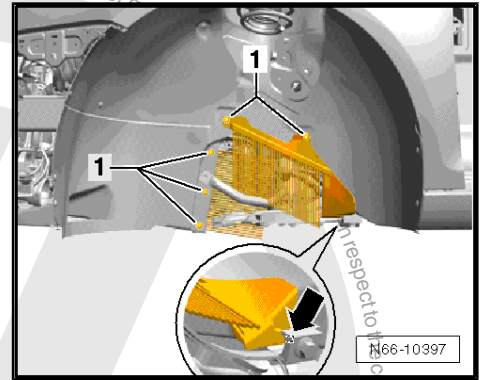

- Remove bolts -2- from protective part -1-.

**Note**

The protective parts may have a different appearance depending on engine fitted.

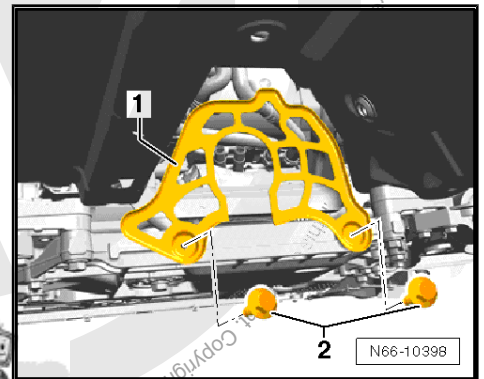

8.1.2 Installing

- Insert front protective part for vermin repellent system; when doing this, pay attention to guide -arrow-.
- Screw in bolts -1- (2 Nm).

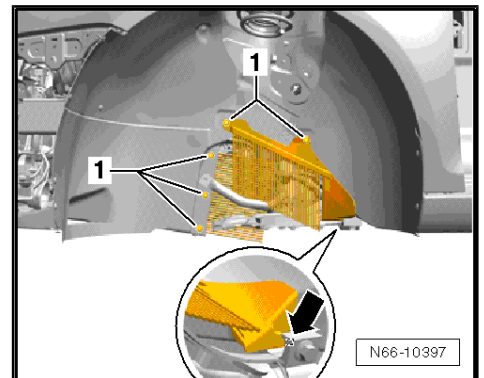

- Screw in bolts -2- for protective part -1- (25 Nm).

