

Drive axle, servicing

Drive axles assembly overview

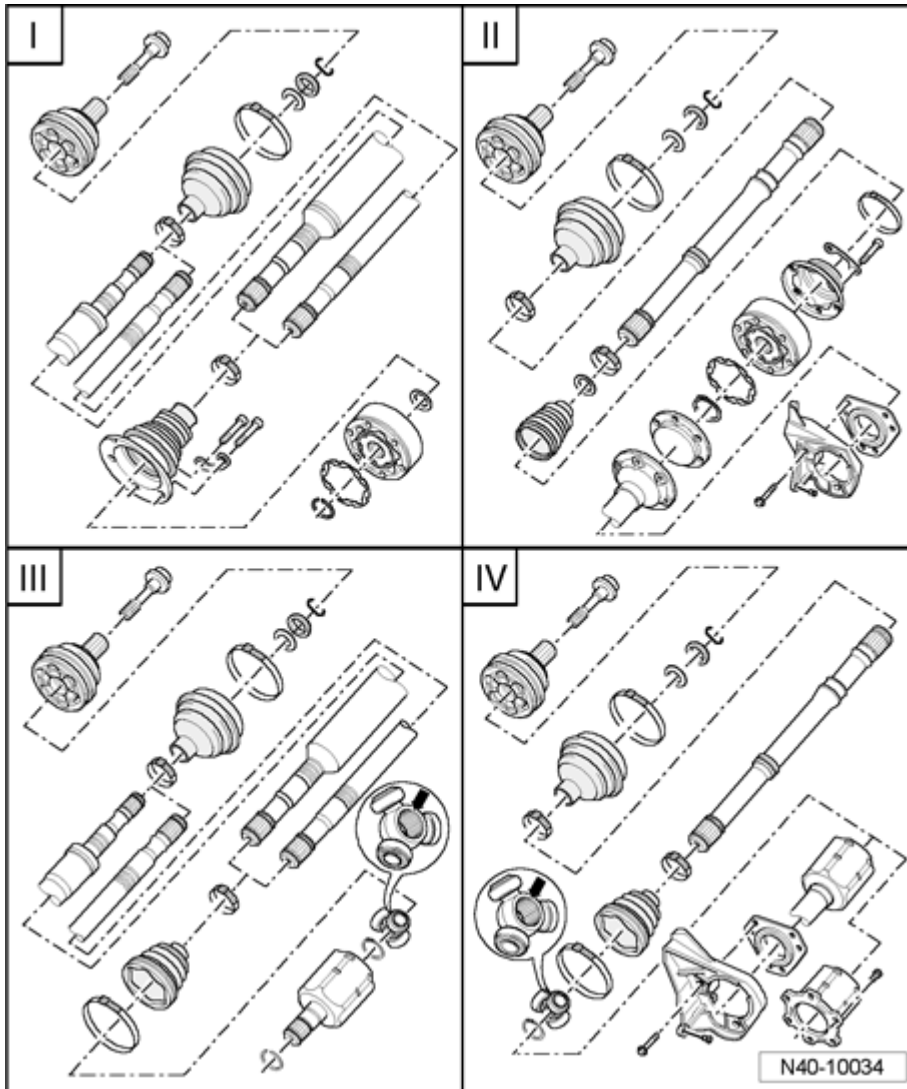

I - Drive axle with Constant Velocity (CV) joint VL90 and VL100, assembly Overview ⇒ [40-7, Drive axle with Constant Velocity \(CV\) joint VL90 and VL100, assembly overview](#)

II - Drive axle with constant velocity joint VL 107, assembly Overview ⇒ [40-7, Drive axle with constant velocity joint VL 107, assembly overview](#)

III - Drive axle with triple roller joint AAR2600i, assembly Overview ⇒ [40-7, Drive axle with triple roller joint AAR2600i, assembly overview](#)

IV - Drive axle with triple roller joint
AAR3300i, assembly Overview ⇒ [40-7](#),
[Drive axle with triple roller joint](#)
[AAR3300i, assembly overview](#)

Distinction of drive axles when installed

	VL90	VL100	VL107	AAR2600i	AAR3300i
Diameter of inner joint in mm	90	100	107	-	-
Cover between inner joint and flange shaft	-	X	X	-	-
With mounting bracket on right side	-	-	X	-	X
Inner joint inserted into transmission	-	-	-	X	-

Drive axle hex bolt connection, loosening and tightening

Special tools, testers and auxiliary items required

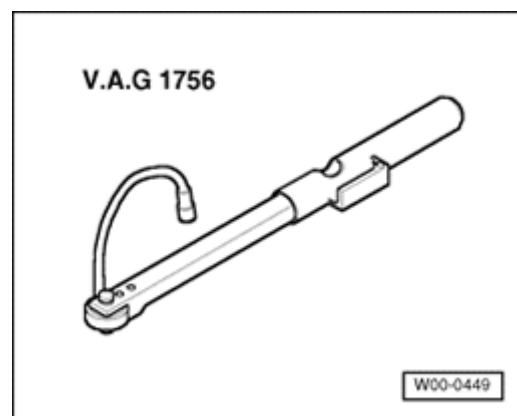

- Angle wrench V.A.G 1756

Wheel bearings must not be burdened when drive axle connection is loose.

If bearings are loaded by the vehicles own weight the wheel bearing will be damaged. The wheel bearings will be stressed and the life expectancy reduced. Note the following:

- Procedure for loosening hex bolt.

Vehicles without drive axle must not be moved, otherwise wheel bearing will be damaged. If vehicle must be moved, observe the following:

- Install an outer joint in place of drive axle.
- Tighten outer joint to 120 Nm.

Loosen hex bolt

- Loosen hex bolt when vehicle is still on its wheels, otherwise wheel bearing will be pre-damaged.
- Lift vehicle enough that wheels hang free.
- Apply brake (second technician required).

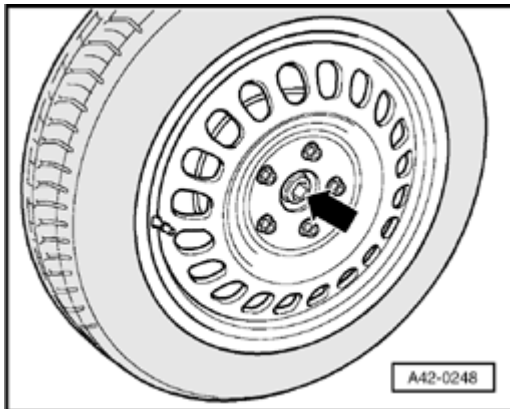

- Remove hex bolt - **arrow** - .

Bolting hex bolt

- Replace hex bolt.

Note:

- *Wheels may not yet touch ground for tightening drive axle, otherwise wheel bearing may be pre-damaged.*

- Apply brake (second technician required).
- Tighten hex bolt to 200 Nm.
- Lower vehicle onto its wheels.
- Turn bolt an additional 180 ° .

Drive axles, removing and Installing

Special tools, testers and auxiliary items required

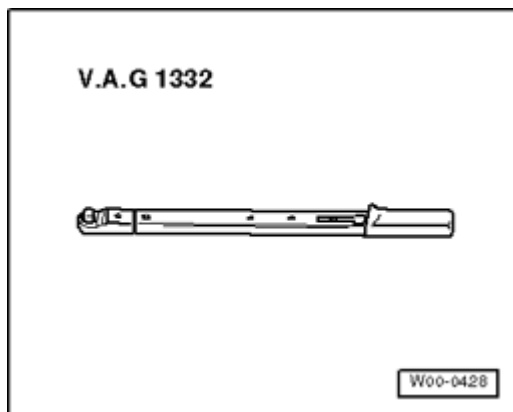

- Torque wrench V.A.G 1332

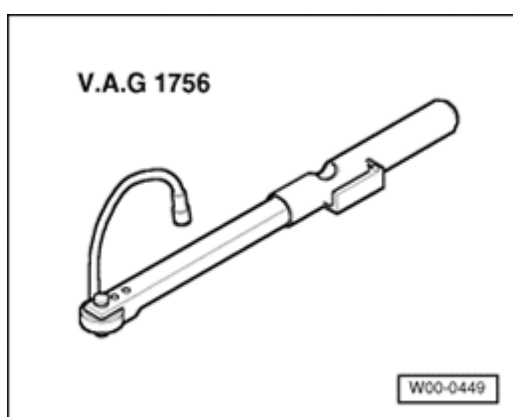

- Angle wrench V.A.G 1756

Caution!

When disassembling and assembling vehicle, drive axles must not hang down loose or reach stop in joints by over-bending.

Drive axle with constant velocity joint, removing

- Loosen drive axle hex bolt ⇒ [40-7, Drive axle hex bolt connection, loosening and tightening](#) .

Note:

- *When doing this, the vehicle must not stand on wheels, otherwise wheel bearing may be damaged.*

- Remove lower noise insulation

⇒ *Repair Manual, Body Exterior, Repair Group 50,*

- Remove drive axle from flange shaft/transmission.
- Remove wheel.
- Slide outer joint out of wheel hub by hand.

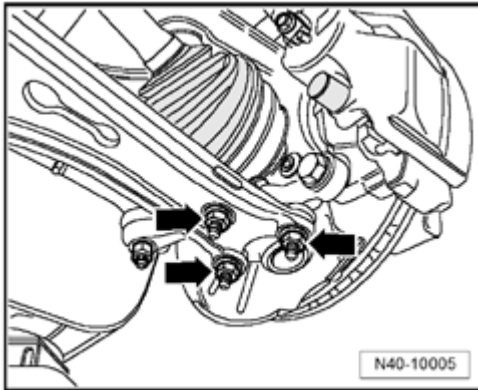

- Remove nuts - **arrows** - .
- Pull wheel bearing housing with ball joint out of control arm.
- Pull drive axle out of wheel hub.

Drive axle with constant velocity joint, installing

Remove any paint residue and/or corrosion in threads/splines of outer joint.

- Insert drive axle.
- Insert outer joint as far as possible into splines in wheel hub.

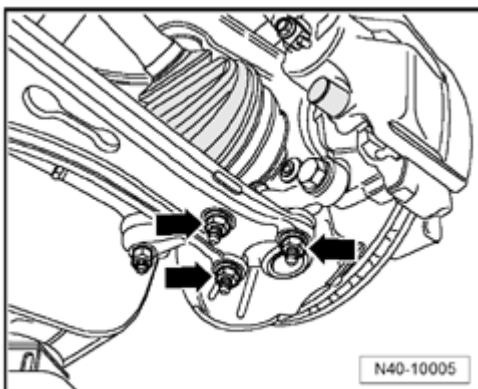

- Bolt on ball joint with control arm - **arrows** - .

Note:

- *Check boot for damage or twisting.*

- Place drive axle inner joint in position and pre-tighten bolts diagonally to 5 Nm.
- Tighten multi-point socket head bolts diagonally to torque specification listed.
- Remove lower noise insulation

⇒ *Repair Manual, Body Exterior, Repair Group 50,*

.

- Tighten drive axle hex bolt.

Note:

- *When doing this, vehicle must not stand on wheels, otherwise wheel bearing may be damaged.*

- Install wheel and tighten ⇒ [44-2, Torque specification for wheel bolts](#) .

Torque specifications ⇒ [40-3, Front axle, tightening torques](#)

Drive axles with triple roller joint AAR2600i, removing

- Loosen drive axle hex bolt ⇒ [40-7, Drive axle hex bolt connection, loosening and tightening](#) .
- Remove wheel.
- Remove lower noise insulation

⇒ *Repair Manual, Body Exterior, Repair Group 50,*

.

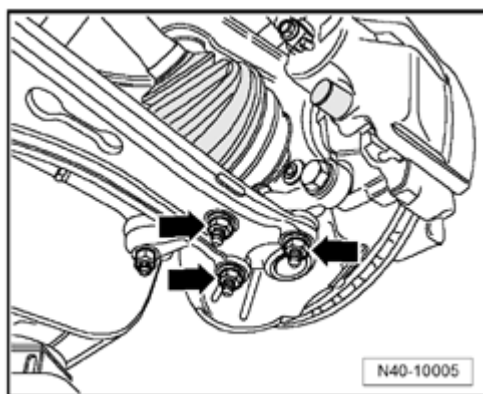

- Remove nuts - **arrows** - .
- Pull wheel bearing housing with ball joint out of control arm.
- Pull drive axle out of wheel hub and secure to body.

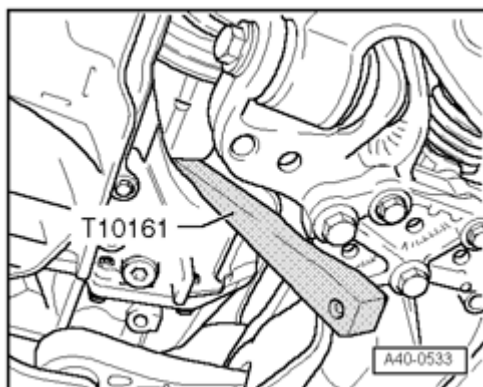

- Attach wedge tool T10161 between transmission housing and triple roller joint.
- Press inner joint out of transmission by tapping with hammer onto wedge tool T10161 .
- Remove drive axle.

Drive axles with triple roller joint AAR2600i, installing

- Insert new circlip into groove of joint piece bolt.
- Mesh outer and inner splines of joint piece and transmission.
- Grasp drive axle by hand and slide into joint piece until stop.
- Slide joint piece into transmission with a "jerk" .

Sliding part in joint piece can be used for this "jerk" . Do not pull drive axle out of joint piece too far when doing this.

Note:

- *Do not use hammer or other knocking tool under any circumstance!*

- Check drive axle in transmission for proper seating by pulling joint piece against resistance from circlip.

For this check, do not pull drive axle but pull joint piece only.

- Insert outer joint as far as possible into the splines in the wheel hub.

- Remove lower noise insulation

⇒ *Repair Manual, Body Exterior, Repair Group 50,*

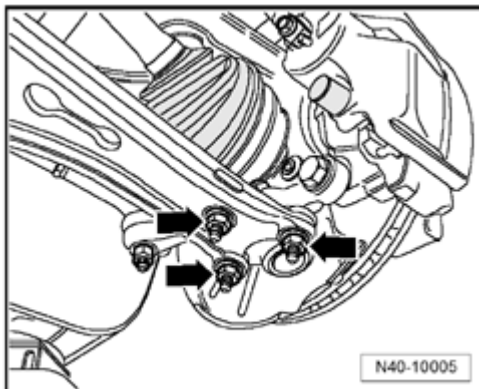

- Bolt ball joint to control arm - **arrows** - .

Note:

- *Check boot for damage or twisting.*

- Tighten drive axle hex bolt.

Note:

- *Vehicle must not stand on wheels, otherwise wheel bearing may be damaged.*

- Install wheel and tighten ⇒ [44-2, Torque specification for wheel bolts](#) .

Torque specifications ⇒ [40-3, Front axle, tightening torques](#)

Drive axles with triple roller joint AAR3300i, removing

- Loosen drive axle hex bolt ⇒ [40-7, Drive axle hex bolt connection, loosening and tightening](#) .

- Remove wheel.
- Remove lower noise insulation

⇒ *Repair Manual, Body Exterior, Repair Group 50,*

- Remove drive axle from flange shaft/transmission.

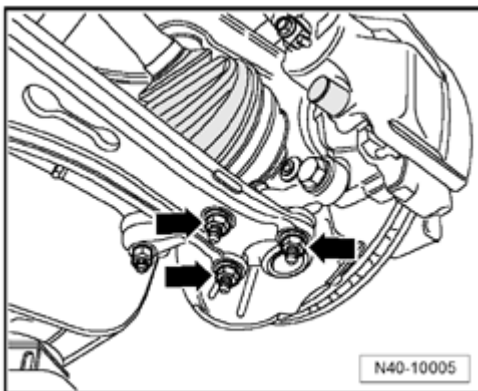

- Remove nuts - **arrows** - .
- Pull wheel bearing housing with ball joint out of control arm.
- Pull drive axle out of wheel hub.

Drive axles with triple roller joint AAR3300i, installing

Remove any paint residue and/or corrosion in threads/splines of outer joint.

- Insert drive axle.
- Insert outer joint as far as possible into the wheel hub splines.

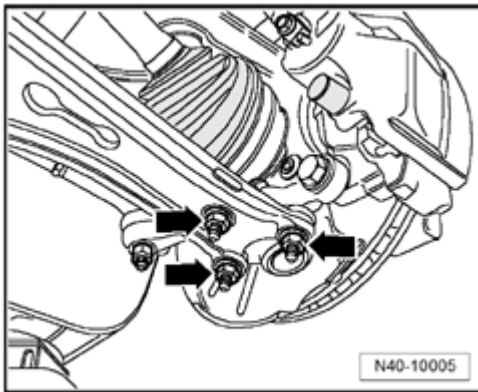

- Bolt on ball joint with control arm - **arrows** - .

Note:

- *Check boot for damage or twisting.*

- Place drive axle inner joint in position and pre-tighten bolts diagonally to 5 Nm.
- Tighten multi-point socket head bolts diagonally to torque specification listed.
- Install lower noise insulation.

⇒ *Repair Manual, Body Exterior, Repair Group 50,*

- Tighten drive axle hex bolt.

Note:

- *Vehicle must not stand on wheels, otherwise wheel bearing may be damaged.*

- Install wheel and tighten ⇒ [44-2, Torque specification for wheel bolts](#) .

Torque specifications ⇒ [Topic 40-3](#)

Intermediate shaft, removing and installing

Removing

Special tools, testers and auxiliary items required

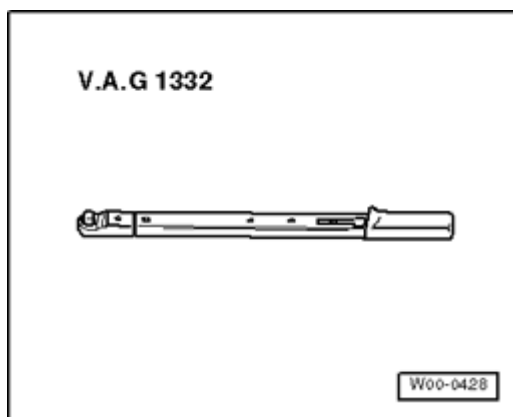

- Torque wrench V.A.G 1332

- Remove drive axle on right side ⇒ [40-7, Drive axle with constant velocity joint, removing](#) .

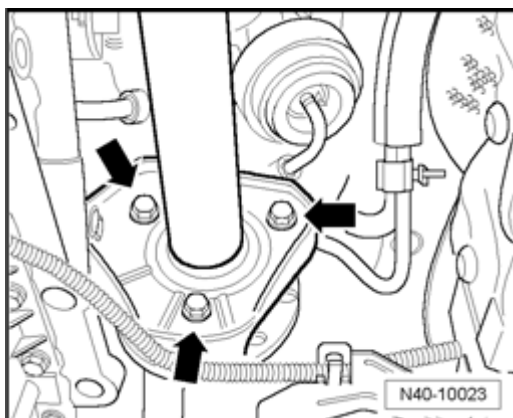

- Loosen bolts - **arrows** - on mounting bracket.
- Pull intermediate shaft off from transmission.

Intermediate shaft, servicing ⇒ [40-7, Intermediate shaft, servicing](#) .

Installing

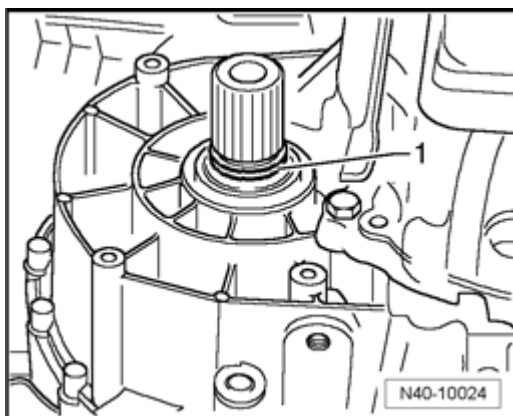

- Replace seal - **1** - on transmission.

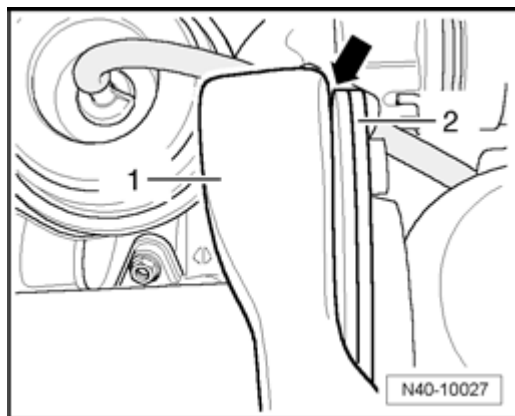

- Push intermediate shaft as far onto transmission shaft until mount - **2** - rests against mounting bracket - **1** - "without any gaps" .

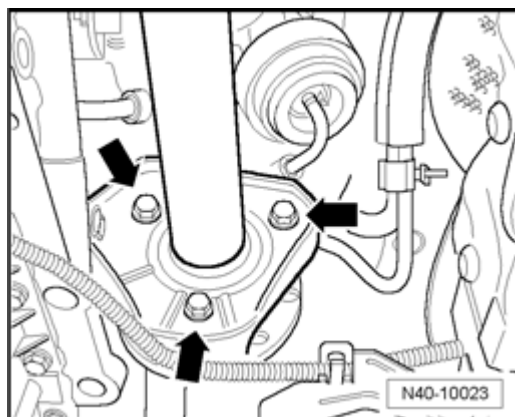

- Fasten bolts - **arrow** - to torque specification.

- Install drive axle ⇒ [40-7, Drive axle with constant velocity joint, installing](#) .

Torque specifications ⇒ [Topic 40-3](#)

Drive axle with Constant Velocity (CV) joint VL90 and VL100, assembly overview

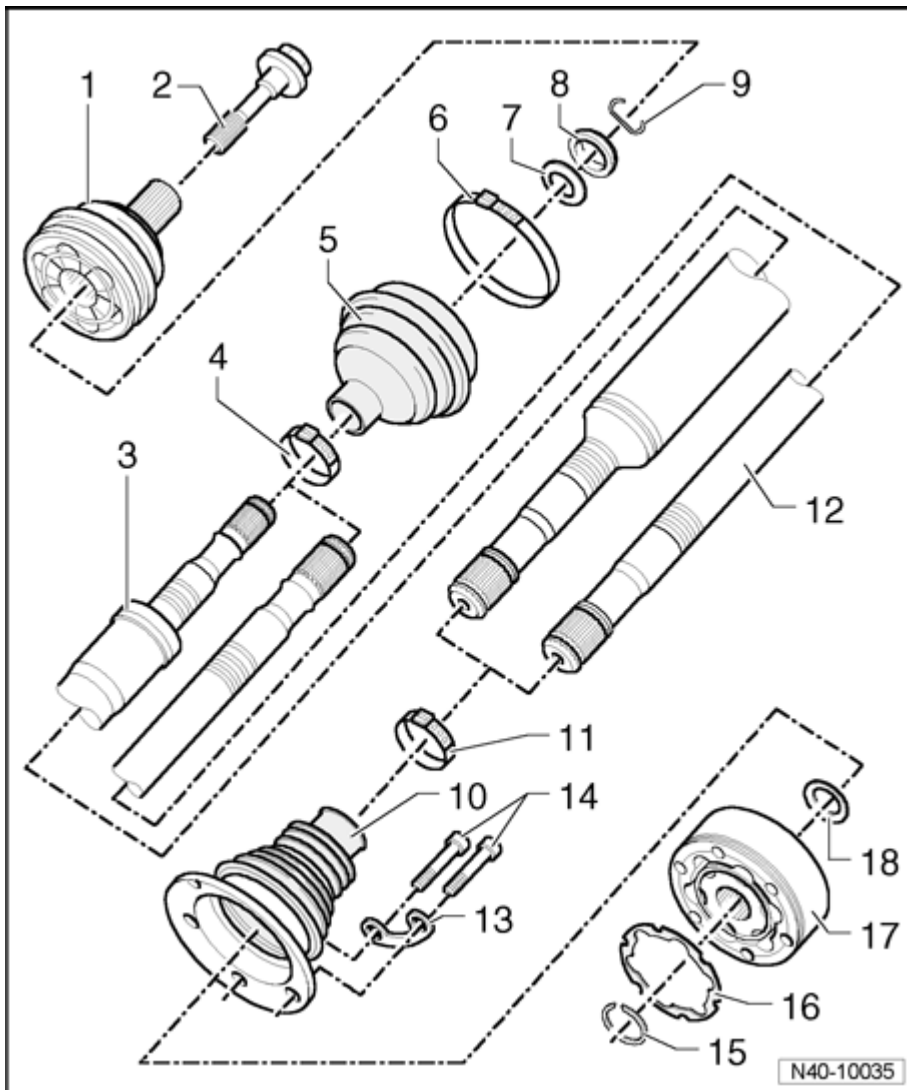

■ Outer constant velocity joint

- Replace as a unit
- Removing ⇒ [40-7, Pressing off outer constant velocity joint](#)
- Installing: Drive onto shaft until impact using plastic hammer
- Checking ⇒ [40-7, Outer constant velocity \(CV\) joint, checking](#)

■ Hex bolt

- Torque specifications ⇒ [Topic 40-3](#)
- Always replace after

removal

- **Right drive axle**

- **Clamp**

- Always replace after removal
- Tensioning ⇒ [40-7, Tensioning clamp on small diameter](#)

- **CV boot**

- Check for tears and chafing
- Material: Hytrel (Polyelastomer)

- **Clamp**

- Always replace after removal
- Tensioning ⇒ [40-7, Tightening hose clamp on outer joint](#)

- **Spring washer**

- Installed location ⇒ [40-7, Installed location of spring washer and thrust washer on outer joint](#)

- **Thrust washer**

- Installed location ⇒ [40-7, Installed location of spring washer and thrust washer on outer joint](#)

- **Circlip**

- Always replace after removal
- Insert in shaft groove

- **CV boot**

- Material: Hytrel (Polyelastomer)
- Without ventilation bore
- Check for tears and chafing
- Drive off constant velocity joint using drift
- Coat sealing surface with D 454 300 A2 before installing on CV joint

- **Clamp**

- Always replace after removal
- Tensioning ⇒ [40-7, Tensioning clamp on small diameter](#)

- **Left drive axle**

- **Backing plate**

- **Multi-point socket head bolt**

- Torque specification ⇒ [Topic 40-3](#)
- Always replace after removal

- **Circlip**

- Remove and install using VW 161 a

- **Gasket**

- Bonding surface on constant velocity joint must be free of grease and oil!

- **Inner constant velocity (CV) joint**

- Replace only as a unit

- Pressing off ⇒ [40-7, Pressing off inner constant velocity joint](#)
 - Pressing on ⇒ [40-7, Pressing on inner constant velocity \(CV\) joint](#)
 - Checking ⇒ [40-7, Inner constant velocity \(CV\) joint, checking](#)
-
- **Spring washer**
 - Installed location ⇒ [40-7, Installed location of spring washer on inner joint](#)

Disassembling

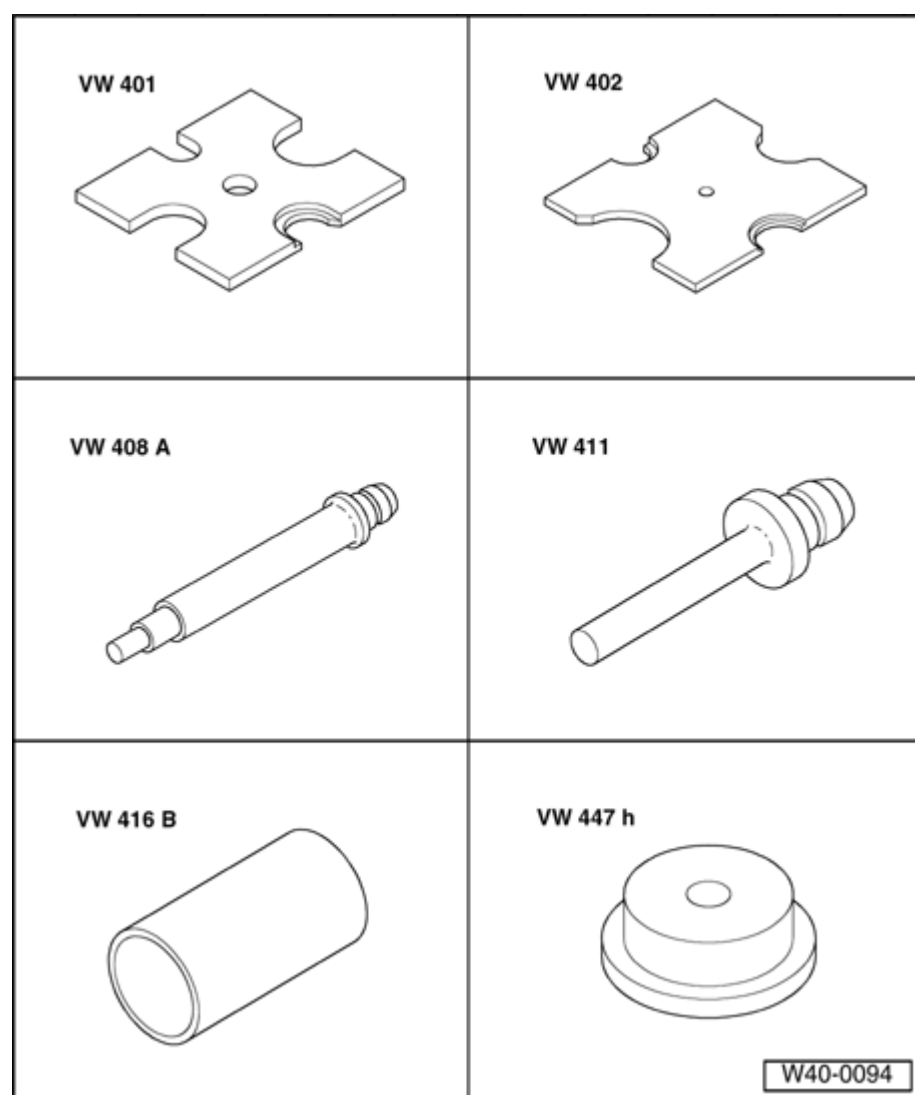

Special tools, testers and auxiliary items required

- Thrust plate VW 401
- Thrust plate VW 402
- Punch VW 408 A
- Punch VW 411
- Sleeve VW 416 B
- Thrust pad VW 447 H

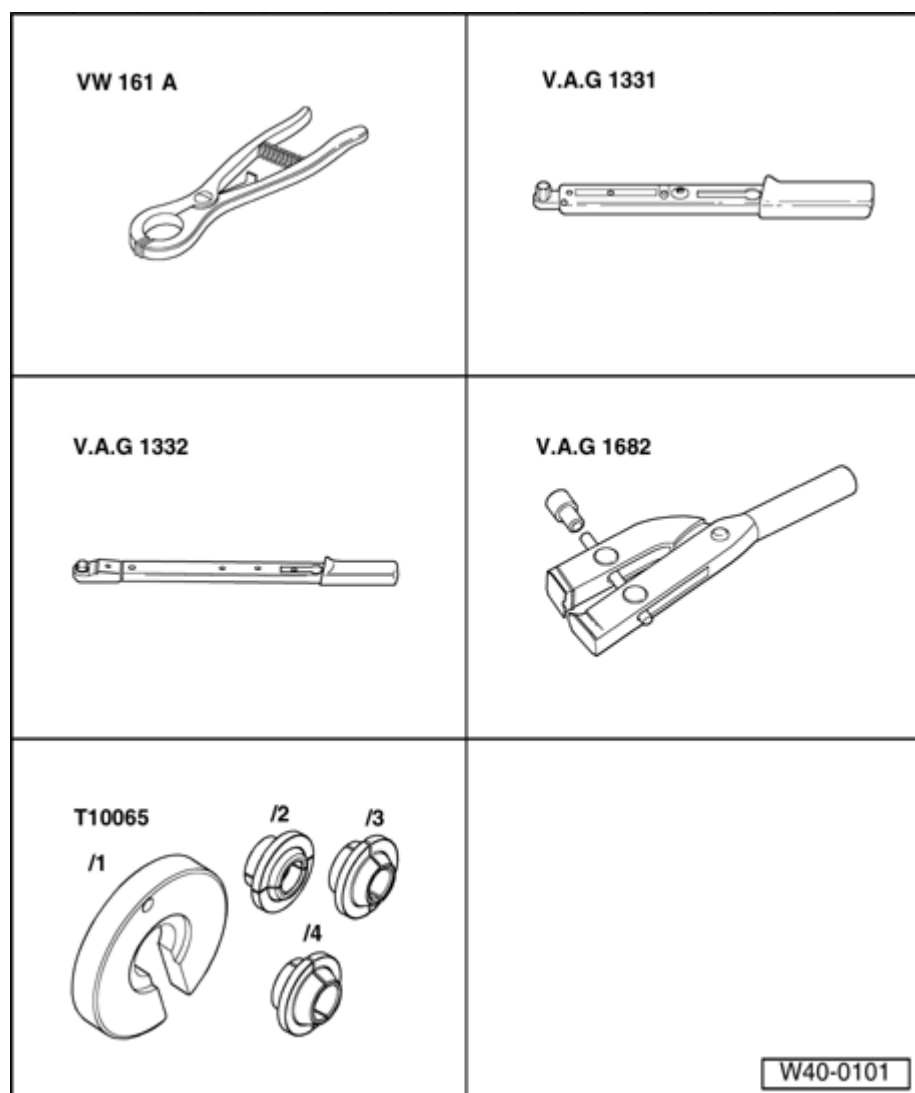
**Special tools, testers and auxiliary items**

required

- Circlip pliers VW 161 A
- Torque wrench V.A.G 1331
- Torque wrench V.A.G 1332
- CV joint boot clamp tool V.A.G 1682
- Assembly tool T10065

- Drive off drive axle by hitting forcefully using plastic hammer.

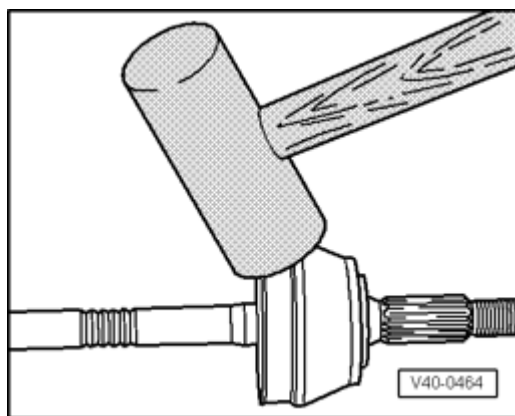
**Pressing off outer constant velocity joint**

- Press off CV from joint using drift.

For constant velocity joint VL 107

- Drive off cover from joint using drift.

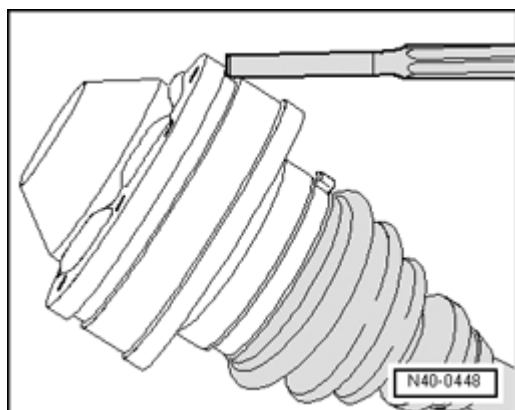

Drive off cover for inner joint

Continued for all CV joints

- Remove circlip.
- Remove both clamps and slide CV boot toward outer joint.

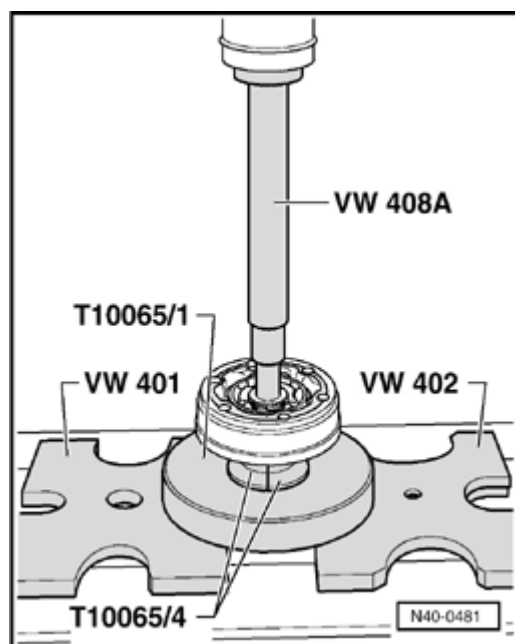

Pressing off inner constant velocity joint

Assembling

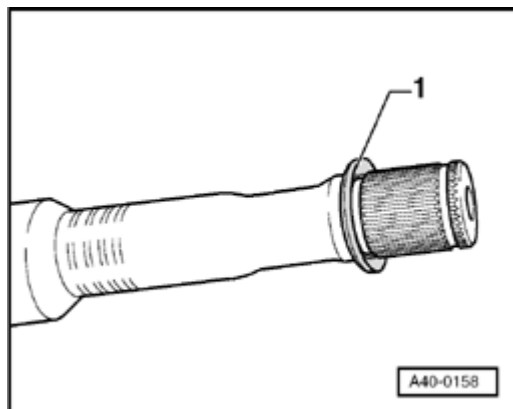

Installed location of spring washer on inner joint

- Spring washer

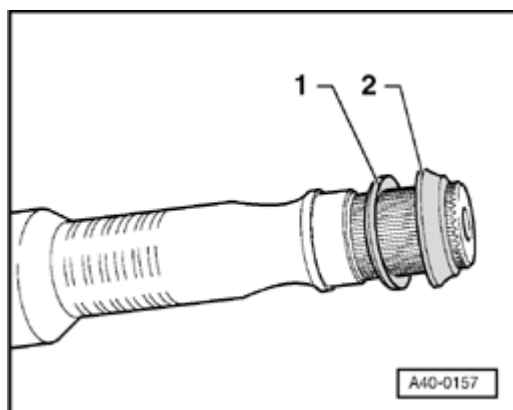

Installed location of spring washer and thrust washer on outer joint

- Spring washer
 - Thrust washer
- Press on joint until stop.
 - Insert circlip.

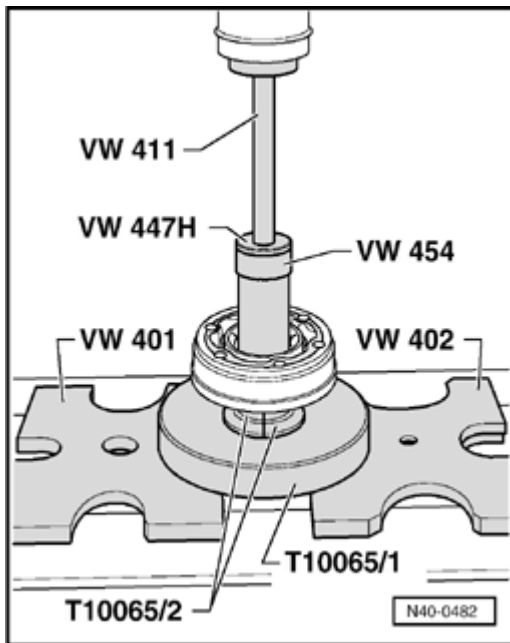

Pressing on inner constant velocity (CV) joint

Note:

- Chamfer on inner diameter of ball hub (splines) must face contact shoulder of drive axle.

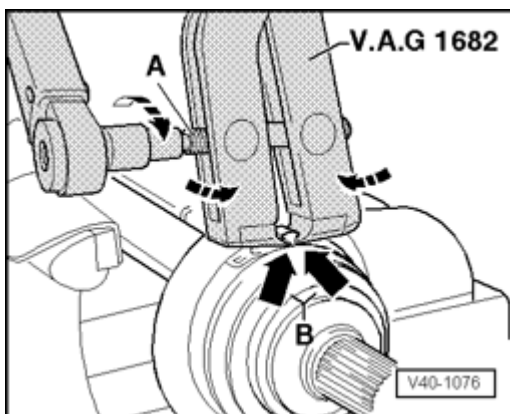

Tightening hose clamp on outer joint

- Attach CV joint boot clamp tool V.A.G 1682 as shown in illustration. Make sure that the jaws of the tension clamp seat in the corners - **arrows B** - of the hose clip.
- Tension clamp by turning spindle with a torque wrench (do not tilt clamp tool).

Note:

- *A stainless steel clamp must be used due to hardness of CV boot material (compared to rubber). This clamp can only be tensioned using CV joint boot clamp tool V.A.G 1682 .*
- *Torque specification: 25 Nm*
- *Use torque wrench - **C** - with adjustment range 5 to 50 Nm (e.g. torque wrench V.A.G 1331).*
- *Be sure thread of spindle - **A** - of clamp tool moves freely. Grease with MOS 2 grease if necessary.*
- *If the thread is tight e.g. dirty, the required tensioning force for the hose clamp will not be achieved in spite of correct torque specification settings.*

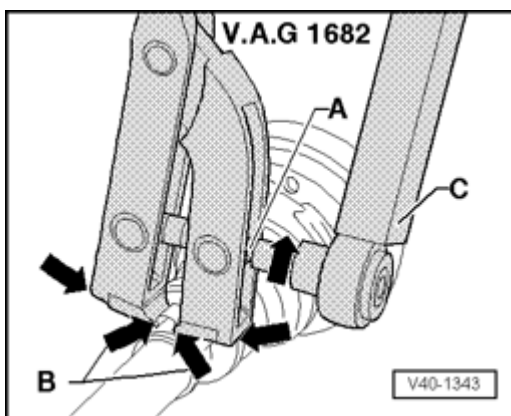

Tensioning clamp on small diameter

Outer constant velocity (CV) joint, checking

In order to replace grease in case of strong soiling, joint must be disassembled or if journal surface of balls must be checked for wear and damage.

Removing:

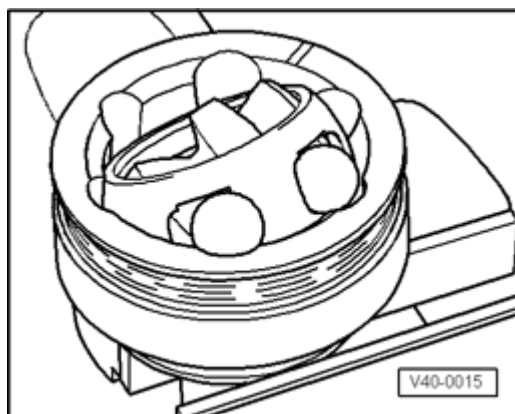

- Before disassembling mark ball hub position in relation to ball cage and housing using an electric scriber or oil stone.
- Swivel ball hub and ball cage.
- Remove balls one after another.

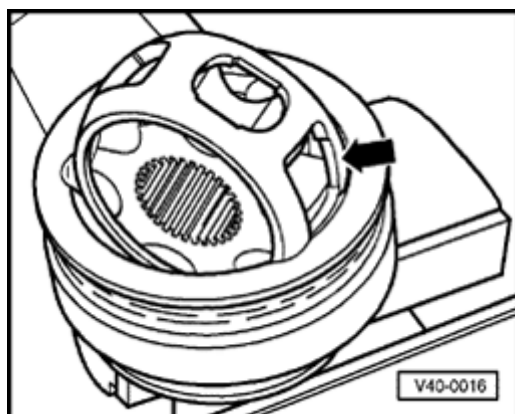

- Turn cage, until two rectangular windows - **arrow** - contact joint body.
- Lift out cage with hub.

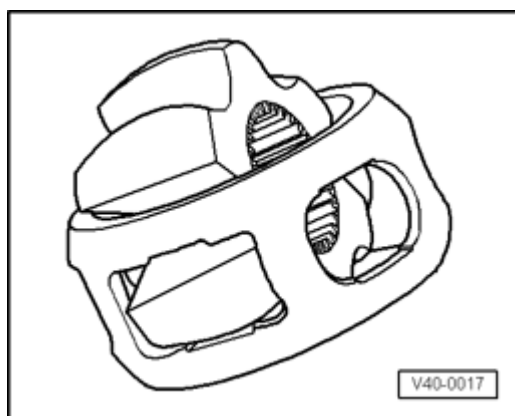

- Swing segment of hub into rectangular window of cage.
- Tilt hub out of cage.

6 balls for each joint belong to a tolerance group. Check

stub axle, hub, cage and balls for small indentations (pitting) and signs of seizure. Excessive circumferential backlash in joint makes itself noticed via tip-in shock, in such cases joint should be replaced. Flattening and running marks of balls are no reason to replace joint.

Installing:

- Press in half of total amount of grease (40 grams) into joint body.
- Install cage with hub in joint housing.
- Press in opposing balls in sequence, previous position of ball hub to ball cage and to joint body must be re-established.
- Install new circlip into hub.
- Distribute remaining grease in cover.

Inner constant velocity (CV) joint, checking

Removing:

In order to replace grease in case of strong soiling, joint must be disassembled and if journal surfaces and balls must be checked for wear and damage.

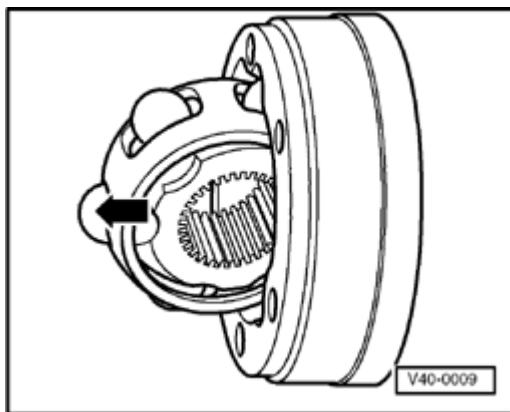

- Swivel ball hub and ball cage.
- Press out ball joint housing in direction of arrow.
- Press balls out of cage.

Note:

- *The ball hub and joint are paired. Must not be interchanged.*

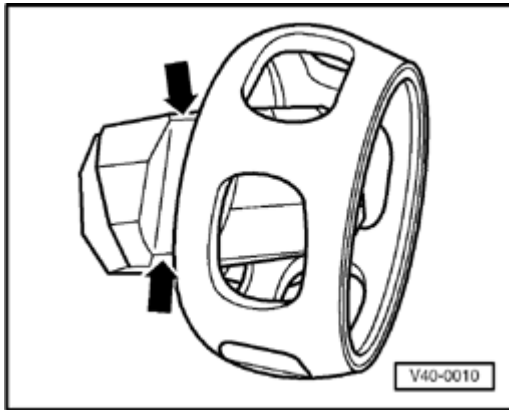

- Flip out ball hub from ball cage via running path of ball - **arrows** - .
- Check joint housing, ball hub, ball cage and balls for indentations (pitting) and signs of seizure.

Excessive circumferential backlash in joint makes itself noticed via tip-in shock. In such cases the joint must be replaced. Flattening and running marks of balls are no reason to replace joint.

Installing:

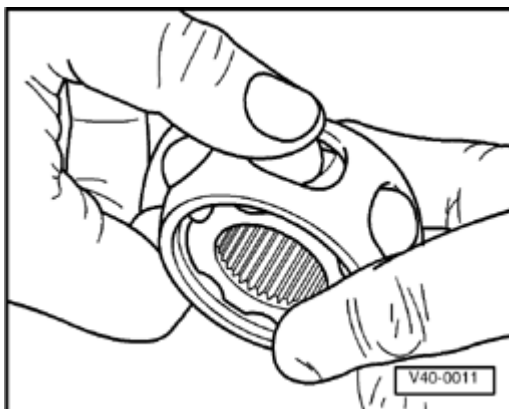

- Insert ball hub into ball cage via two chamfers. The hub can be installed in any position. Press balls into cage.

There are 2 different distances between ball tracks of ball hub, a larger and a smaller one.

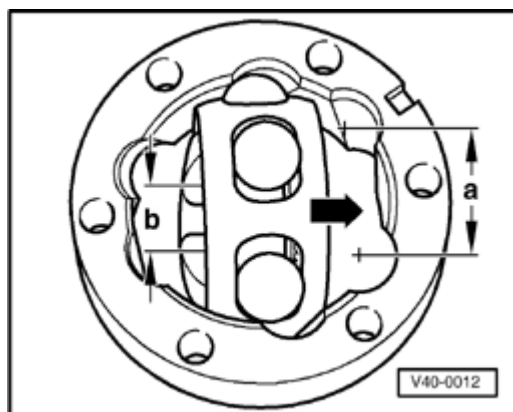

- Insert hub with cage and balls upright into joint piece, a smaller space - **b** - must face toward open side of joint piece when doing this.

- Observe chamfer on inner diameter of ball hub which must be visible after swinging in.

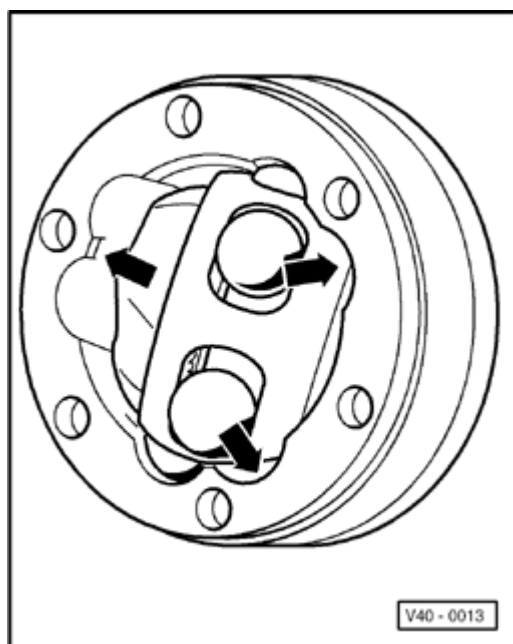

- Swing in ball hub; to do so, swing out hub far enough out of cage - **arrows** - (as depicted in illustration).

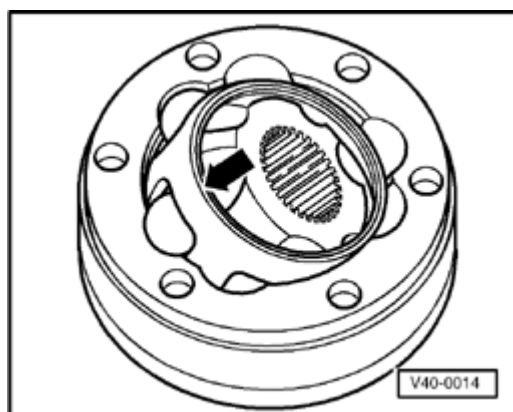

- Press cage firmly - **arrow** - until hub swings fully in position.

Constant velocity joint, checking for function:

Constant velocity joint is properly assembled, if ball hub can be slid back and forth by hand over whole compensation length.

Drive axle with constant velocity joint VL 107, assembly overview

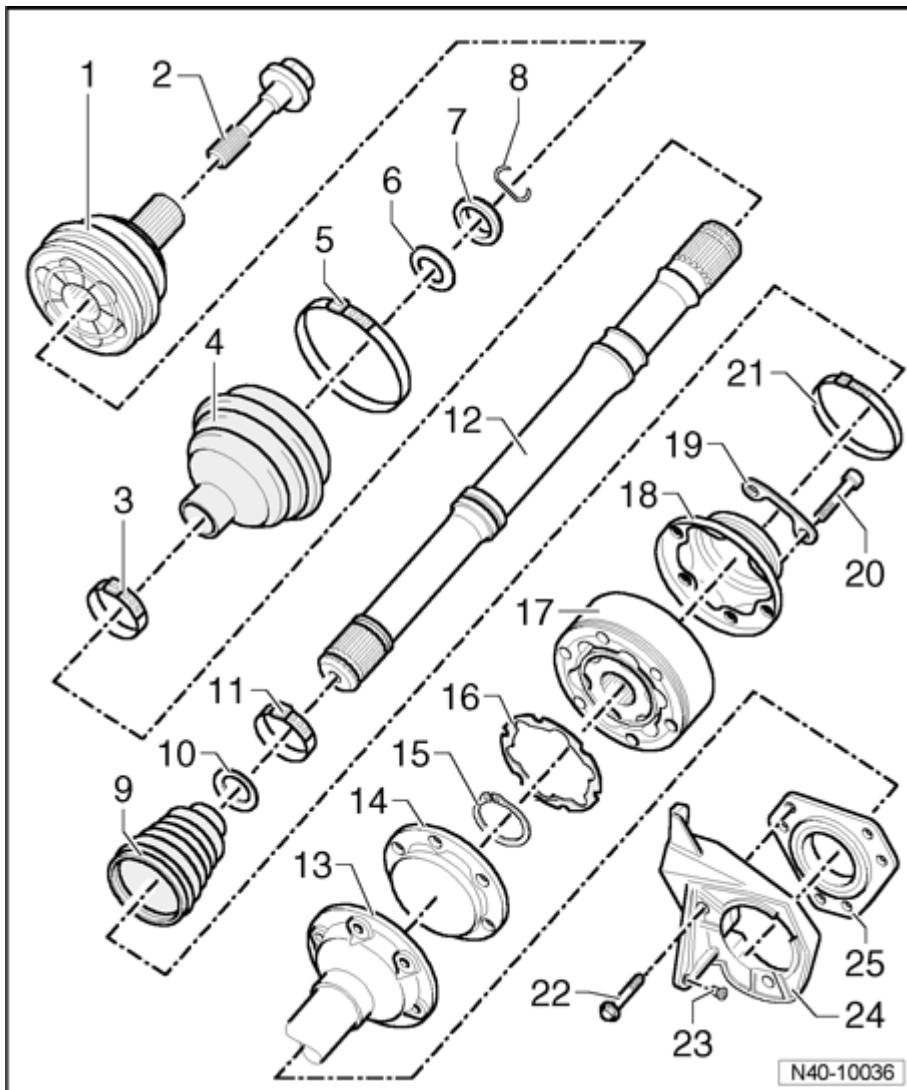

■ Outer constant velocity joint

- Replace only as a unit
- Removing ⇒ [40-7, Pressing off outer constant velocity joint](#)
- Installing: Drive onto shaft until impact using plastic

hammer

- Checking ⇒ [40-7, Outer constant velocity \(CV\) joint, checking](#)

- **Hex bolt**
 - Torque specifications ⇒ [Topic 40-3](#)
 - Always replace after removal

- **Clamp**
 - Always replace after removal
 - Tensioning ⇒ [40-7, Tensioning clamp on small diameter](#)

- **Protective boot**
 - Check for tears and chafing
 - Material: Hytrel (Polyelastomer)

- **Clamp**
 - Always replace after removal
 - Tensioning ⇒ [40-7, Tightening hose clamp on outer joint](#)

- **Spring washer**
 - Installed location ⇒ [40-7, Installed location of spring washer and thrust washer on outer joint](#)

- **Thrust washer**
 - Installed location ⇒ [40-7, Installed location of spring washer and thrust washer on](#)

[outer joint](#)

- **Circlip**
 - Always replace after removal
 - Insert in shaft groove

- **Constant velocity joint boots**
 - Material: Hytrel (Polyelastomer)
 - Without ventilation bore
 - Check for tears and chafing
 - Drive off constant velocity joint using drift
 - Coat sealing surface with D 454 300 A2 before installing on constant velocity joint

- **Spring washer**
 - Installed location ⇒ [40-7, Installed location of spring washer on inner joint](#)

- **Clamp**
 - Always replace after removal
 - Tensioning ⇒ [40-7, Tensioning clamp on small diameter](#)

- **Axle shaft**
- **Intermediate shaft**
 - Right side of vehicle
 - Removing and installing ⇒ [40-7, Intermediate shaft, removing and installing](#)

- **Cover**

- Always replace after removal
- Always replace
- Pressing off ⇒ [40-7, Drive off cover for inner joint](#)

- **Circlip**
 - Removing and installing circlip pliers VW 161 A

- **Gasket**
 - Bonding surface on constant velocity joint must be free of grease and oil!

- **Inner constant velocity joint**
 - Replace only as a unit
 - Pressing off ⇒ [40-7, Pressing off inner constant velocity joint](#)
 - Pressing on ⇒ [40-7, Pressing on inner constant velocity \(CV\) joint](#)
 - Checking ⇒ [40-7, Inner constant velocity \(CV\) joint, checking](#)

- **Cover**
 - Carefully drive off using drift
 - Coat sealing surface with D 454 300 A2 before installing on constant velocity joint
 - Adhesive surface must be free of oil and grease

- **Backing plate**
- **Multi-point socket head bolt**
Torque specifications ⇒ [Topic](#)

40-3

- Always replace after removal

- **Clamp**
 - Always replace after removal

- **Hex head bolt**
 - Torque specifications ⇒ [Topic 40-3](#)

- **Countersunk bolt**
 - Torque specifications ⇒ [Topic 40-3](#)
 - 3 bolts

- **Mounting bracket**

- **Bushing**
 - Pressing off and on ⇒ [Topic 40-3](#)

Disassembling

⇒ [40-7, Disassembling](#)

Assembling

⇒ [40-7, Assembling](#)

Outer constant velocity (CV) joint, checking

⇒ [40-7, Outer constant velocity \(CV\) joint, checking](#)

Inner constant velocity (CV) joint, checking

⇒ [40-7, Inner constant velocity \(CV\) joint, checking](#)

Constant velocity joint, checking for function

⇒ [40-7, Constant velocity joint, checking for function:](#)

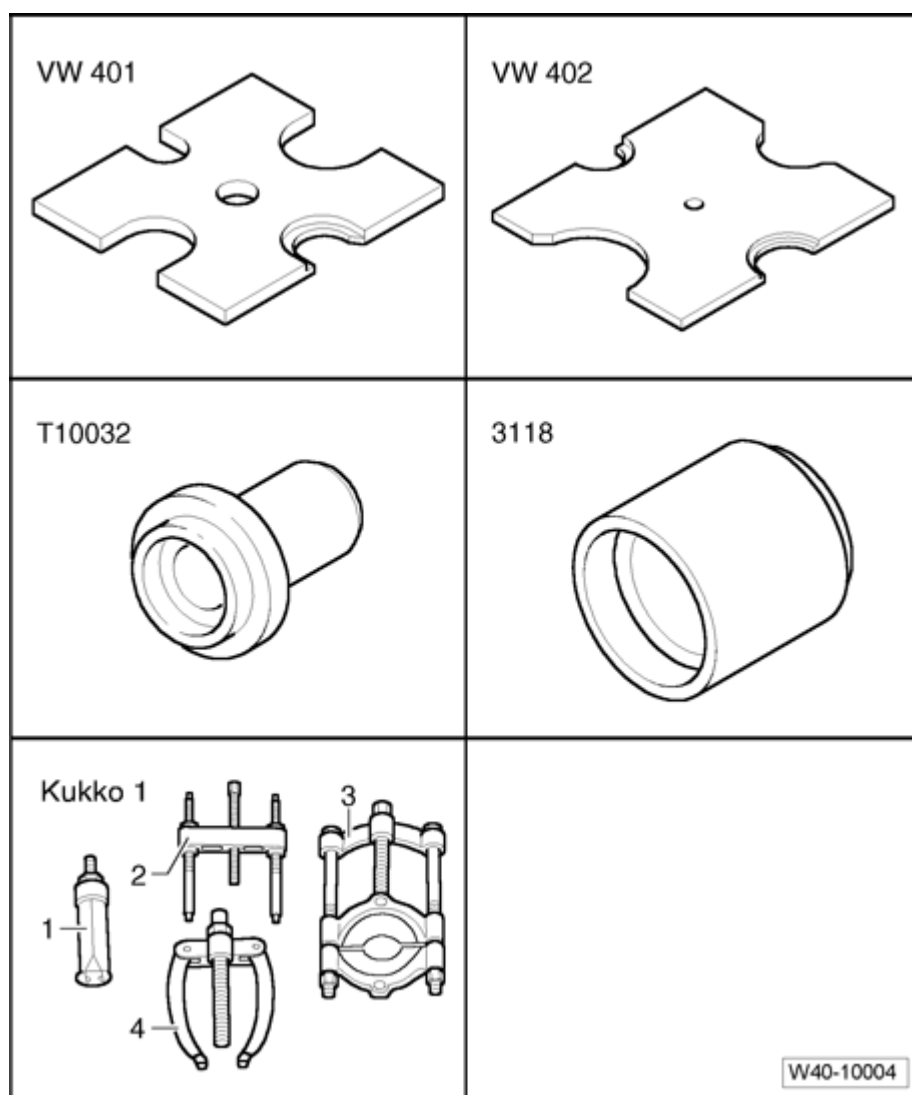
Intermediate shaft, servicing**Special tools, testers and auxiliary items required**

- Thrust plate VW 401
- Thrust plate VW 402
- Press piece T10032
- Press piece 3118
- Kukko separating tool 15-2

Pressing off bearing

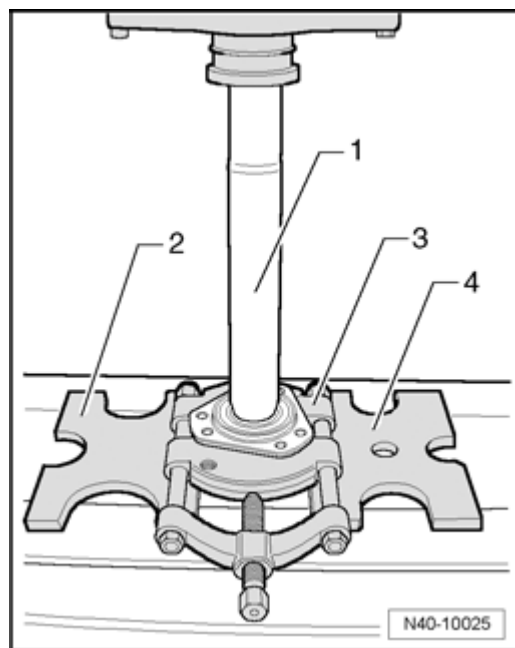

- Press bearing off from intermediate shaft as shown in illustration.

The jaws of Kukko separating tool 15-2 must face toward shaft.

- Intermediate shaft with bearing
- Thrust plate VW 402
- Thrust plate VW 401
- Kukko separating tool 15-2

Note:

- *When pressing out, hold the shaft tightly.*

Pressing on bearing

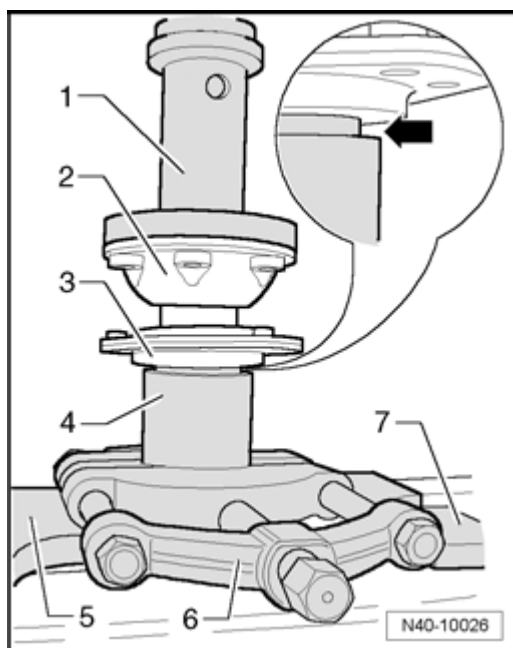

- Press bearing onto intermediate shaft up to stop as shown in the illustration.

- Press piece T10032
- Intermediate shaft
- Bushing
- Press piece 3118
- Thrust plate VW 401
- Kukko separating tool 15-2
- Thrust plate VW 402

The recess - **arrow** - of the press support 3118 must face toward the bearing.

Drive axle with triple roller joint AAR2600i, assembly overview

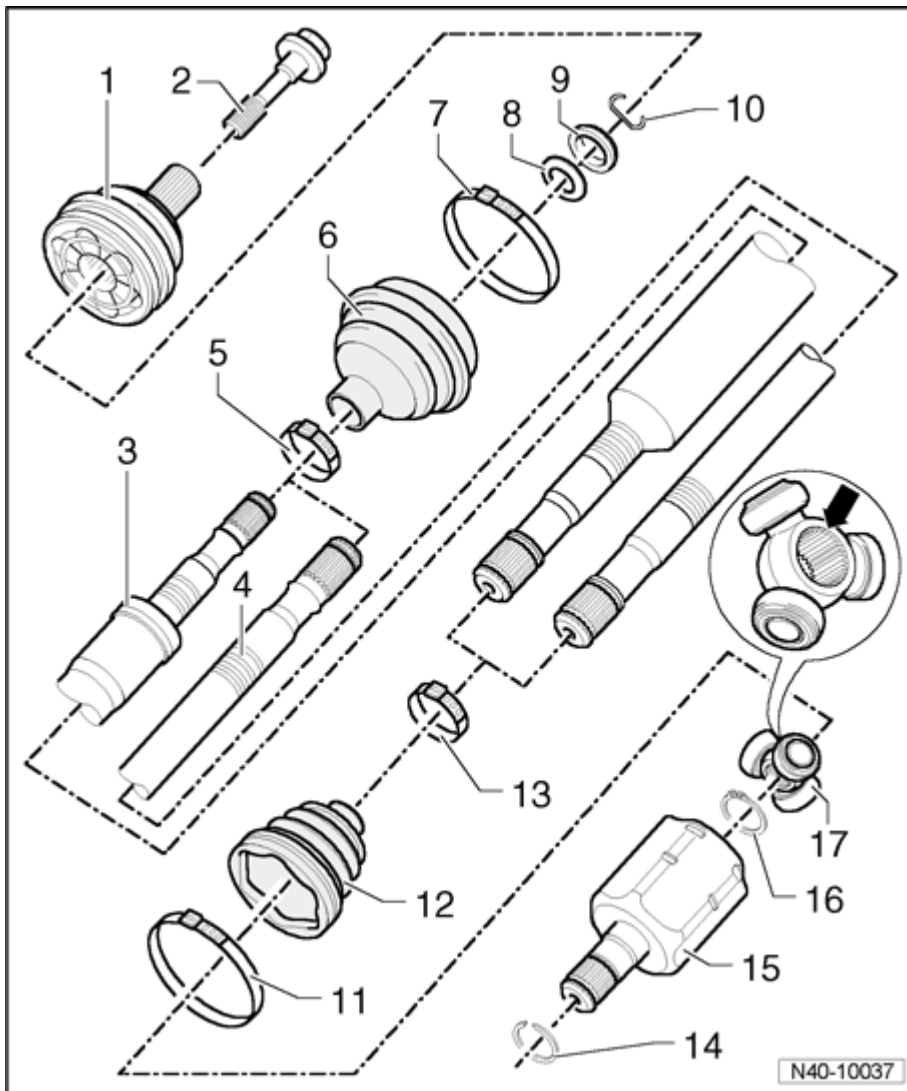

■ Outer constant velocity joint

- Replace only as a unit
- Removing ⇒ [40-7, Pressing off outer constant velocity joint](#)
- Installing: Drive onto shaft using plastic hammer until expanded securing ring contracts
- Checking ⇒ [40-7, Outer constant velocity \(CV\) joint, checking](#)

■ Hex bolt

- Torque specifications ⇒ [Topic 40-3](#)

- Always replace after removal

- **Right drive axle**
- **Left drive axle**
- **Clamp**
 - Always replace after removal
 - Tensioning ⇒ [40-7, Tensioning clamp on small diameter](#)

- **Constant velocity (CV) joint boots**
 - Check for tears and chafing
 - Material: Hytrel (Polyelastomer)

- **Clamp**
 - Always replace after removal
 - Tensioning ⇒ [40-7, Tightening hose clamp on outer joint](#)

- **Spring washer**
 - Installed location ⇒ [40-7, Installed location of spring washer and thrust washer on outer joint](#)

- **Thrust washer**
 - Installed location ⇒ [40-7, Installed location of spring washer and thrust washer on outer joint](#)

- **Circlip**
 - Always replace after

removal

- Insert in shaft groove

- **Clamp**
 - Always replace after removal
 - Tension using hose clamp pliers V.A.G 1275

- **CV boot for triple roller joint**
 - Check for tears and chafing

- **Clamp**
 - Always replace after removal
 - Tension using hose clamp pliers V.A.G 1275

- **Circlip**
 - Always replace after removal

- **Triple roller joint housing**

- **Circlip**
 - Always replace after removal
 - Insert in shaft groove using circlip pliers VW 161 A

- **Triple rotor star with rollers**
**Chamfer - arrow - faces splines
drive axle splines**

Disassembling

Servicing outer joint can be found here ⇒ [40-7, Disassembling](#) .

- Open both clamps at inner joint and slide back CV boot.
- Pull off triple roller joint housing from drive axle.

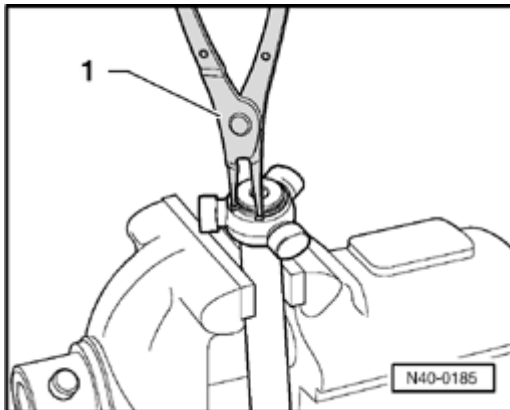

- Remove circlip.

1 - Pliers (commercially available)

- or VW 161 A

- Insert drive axle in vise.

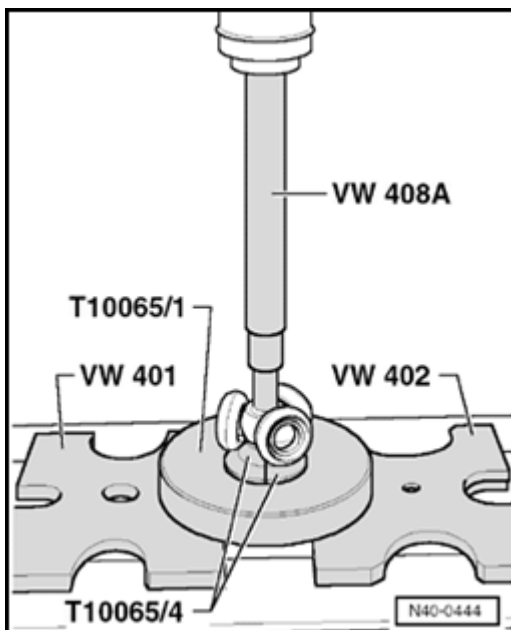

- Press triple roller star off drive axle.
- Pull off CV boot from shaft.
- Clean shaft, joint and groove for oil seal.

Assembling

- Slide small clamp for joint protective boot onto shaft.
- Slide joint protective boot onto shaft.

- Slide joint onto shaft.

Mount triple roller star

Conical drive axle

The chamfer on star faces toward shaft, this is used as an assembly aid.

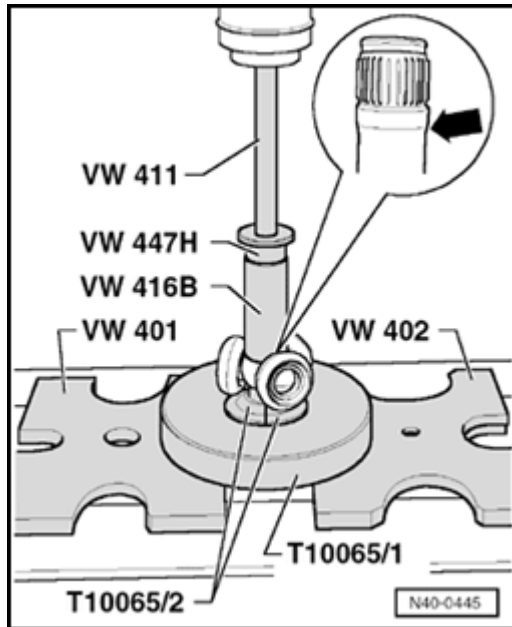

- Install triple roller star onto shaft and press on until stop.
- Make sure pressure does not exceed 3.0 t!
- If necessary, coat drive axle splines and triple roller star using solid lubricant G 052 142 A2.
- Insert circlip, make sure seated correctly.

As of 08.2004, a different grease will be used for triple roller joints. The grease must not be mixed with grease previously used. Therefore, triple roller joint must be cleaned before greasing when performing service work.

- Press 70 grams of joint grease from repair kit, into triple roller joint.
- Slide triple roller joint housing over rollers and secure.
- Press 60 grams of joint grease, from repair kit, into reverse side of triple roller joint.
- Install joint protective boot.

Mount triple roller star

Cylindrical drive axle

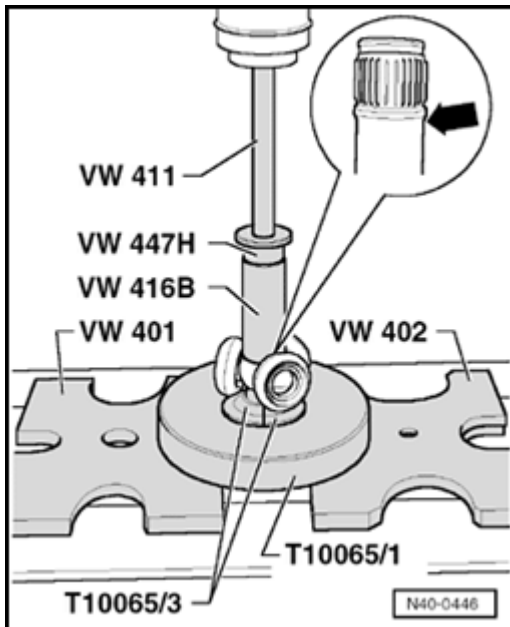

- Install triple roller star onto shaft and press on until stop.
- Make sure pressure does not exceed 3.0 t!
- If necessary, coat drive axle splines and triple roller star using solid lubricant G 052 142 A2.
- Insert circlip, make sure seated correctly.
- Press 70 grams of joint grease from repair kit, into triple roller joint.
- Slide triple roller joint housing over rollers and secure.
- Press 60 grams of joint grease, from repair kit, into reverse side of the triple roller joint.
- Install joint protective boot.
- Tighten both clamps using pliers hose clamp pliers V.A.G 1275 .

Drive axle with triple roller joint AAR3300i, assembly overview

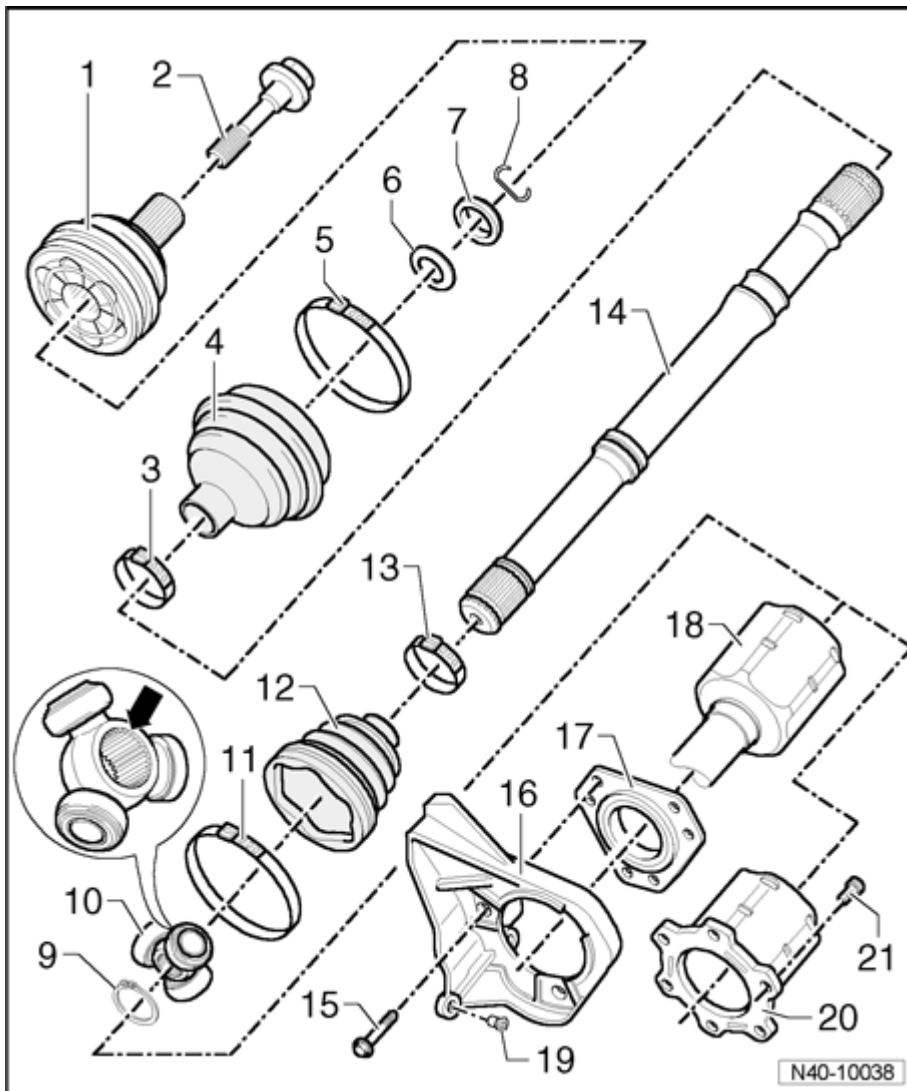

- **Outer constant velocity (CV) joint**
 - Replace only as a unit
 - Removing ⇒ [40-7, Pressing off outer constant velocity joint](#)
 - Installing: Drive onto shaft using plastic hammer until expanded securing ring contracts
 - Checking ⇒ [40-7, Outer constant velocity \(CV\) joint, checking](#)

- **Hex bolt**
 - Torque specifications ⇒ [Topic 40-3](#)

- Always replace after removal

- **Clamp**
 - Always replace after removal
 - Tensioning ⇒ [40-7, Tensioning clamp on small diameter](#)

- **Constant velocity (CV) joint boots**
 - Check for tears and chafing
 - Material: Hytrel (Polyelastomer)

- **Clamp**
 - Always replace after removal
 - Tensioning ⇒ [40-7, Tightening hose clamp on outer joint](#)

- **Spring washer**
 - Installed location ⇒ [40-7, Installed location of spring washer and thrust washer on outer joint](#)

- **Thrust washer**
 - Installed location ⇒ [40-7, Installed location of spring washer and thrust washer on outer joint](#)

- **Circlip**
 - Always replace after removal
 - Insert in shaft groove

- **Circlip**
 - Always replace after removal
 - Insert in shaft groove

- **Triple rotor star with rollers**

**Chamfer - arrow - faces splines
drive axle splines**

- **Clamp**
 - Always replace after removal
 - Tension using hose clamp pliers V.A.G 1275

- **CV boot for triple roller joint**
 - Check for tears and chafing

- **Clamp**
 - Always replace after removal
 - Tension using hose clamp pliers V.A.G 1275

- **Axle shaft**
- **Hex bolt**
 - Torque specifications ⇒ [Topic 40-3](#)

- **Mounting bracket**
- **Bushing**
- **Triple roller joint housing with intermediate shaft**
 - For right side of vehicle

- **Countersunk bolt**

- Torque specifications ⇒ [Topic 40-3](#)

- **Triple roller joint housing**
 - For left side of vehicle

- **Multi-point socket head bolt**
 - Torque specifications ⇒ [Topic 40-3](#)

Disassembling

Servicing outer joint ⇒ [40-7, Disassembling](#) .

- Open both clamps at inner joint and slide back CV boot.
- Pull off triple roller joint housing from drive axle.

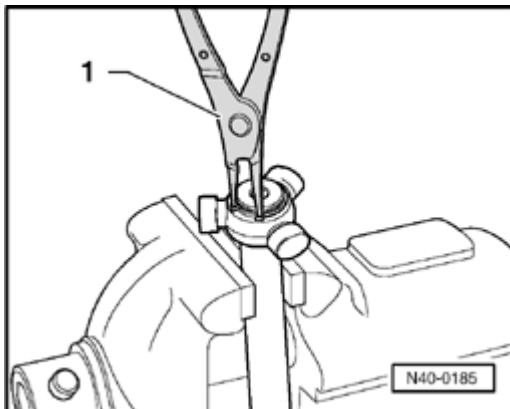

- Remove circlip.

1 - Pliers (commercially available)

- or VW 161 A

- Insert drive axle in vise.

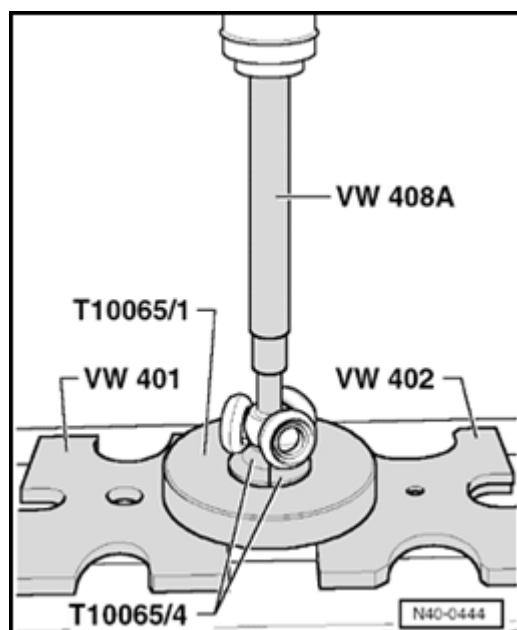

- Press triple roller star off drive axle.
- Pull off CV boot from shaft.
- Clean shaft, joint and groove for oil seal.

Assembling

- Slide small clamp for joint protective boot onto shaft.
- Slide joint protective boot onto shaft.
- Slide joint onto shaft.

Mount triple roller star

Conical drive axle

The chamfer on star faces toward shaft, this is used as an assembly aid.

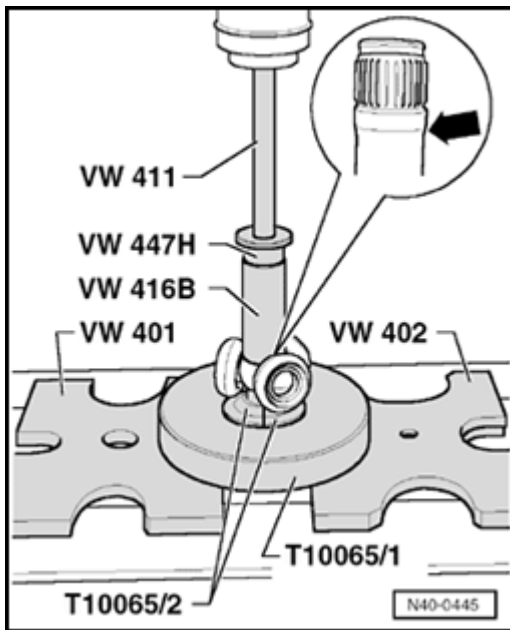

- Install triple roller star onto shaft and press on until stop.
- Make sure pressure does not exceed 3.0 t!
- If necessary, coat drive axle splines and triple roller star using solid lubricant G 052 142 A2.
- Insert circlip, make sure seated correctly.

As of 08.2004, a different grease will be used for triple roller joints. The grease must not be mixed with grease previously used. Therefore, triple roller joint must be cleaned before greasing when performing service work.

- Press 70 grams of joint grease from repair kit, into triple roller joint.
- Slide joint piece over rollers and secure.
- Press 60 grams of joint grease, from repair kit, into reverse side of triple roller joint.
- Install joint protective boot.

Mount triple roller star

Cylindrical drive axle

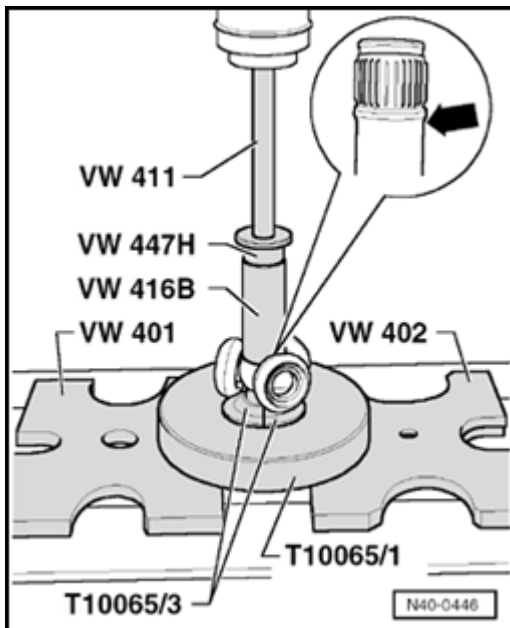

- Install triple roller star onto shaft and press on until stop.
- Make sure pressure does not exceed 3.0 t!
- Coat drive axle splines and triple roller star using solid lubricant G 052 142 A2 if necessary.
- Insert circlip, make sure seated correctly.
- Press 70 grams of joint grease from repair kit, into triple roller joint.
- Slide joint piece over rollers and secure.
- Press 60 grams of joint grease, from repair kit, into the reverse side of triple roller joint.
- Install joint protective boot.
- Install clamp.

Note:

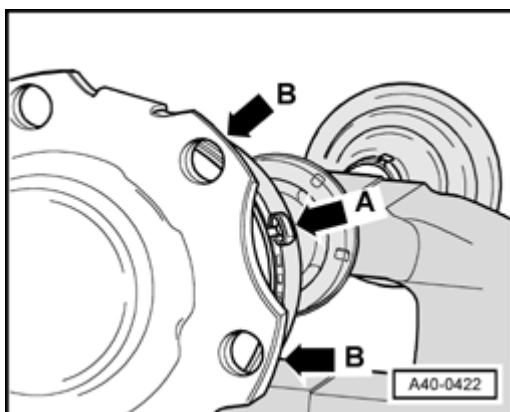

- Position the crimping tab of the clamp - **arrow A** -

between mounting flanges of joint piece - **arrows B**
- . This will facilitate threading the socket head bolts
during installation of the drive axle.

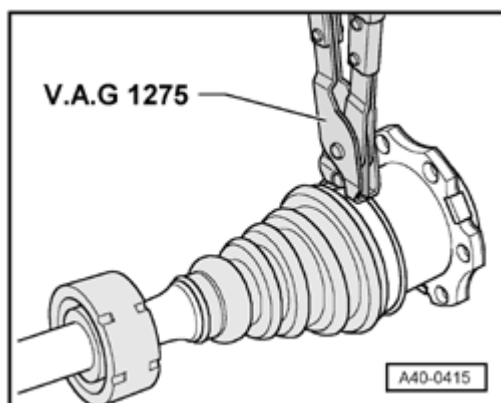

- Tighten clamp using hose clamp pliers V.A.G 1275 .

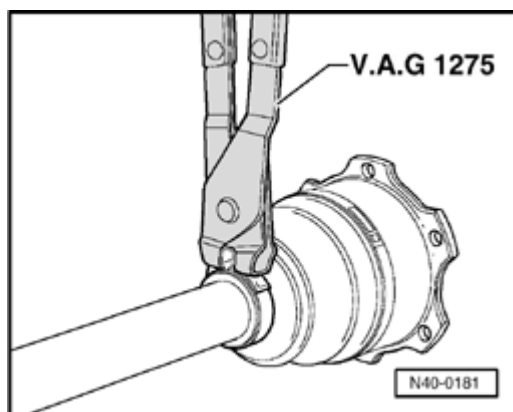

- Tighten small clamp using hose clamp pliers V.A.G 1275 .